

10. Executive Function

Higher Level Cognition: What's Missing

- Planning, problem solving, reasoning, complex decision-making
- What do all of these have in common?
- Top-down control of behavior: Instead of reacting in a bottom-up fashion to stimuli, behavior is driven (controlled) by an actively maintained representation of what we are supposed to be doing
- Allows us to behave in contextually appropriate fashion instead of just giving the strongest, most dominant response
- Also gives us the ability to link events across time points, and to carry out behaviors that are extended across time

Definition of Executive Function

- A process used to effortfully guide behavior towards a goal, especially in non-routine situations
- Multi-faceted, may include:
 - Inhibiting familiar/stereotyped behavior
 - Maintain an idea of which information is relevant right now
 - Resist distracting information
 - Switch between goals
- Definition from Banich (2009)

Very Relevant Example

- How do I get into grad school?
 - Figuring out what I am interested in
 - Working in a lab to learn about research
 - Contacting professors to get recommendations
 - Looking at schools
 - Sending applications & taking tests on time
 - Going to interviews (social skills, learning skills)
 - Making a decision about where to go
 - Listing pros and cons

Why Do We Care?

- Clinical disorders involve impairments in executive function
- Depression:
 - Enhanced focus on negative stimuli
- Addiction
 - Enhanced focus on & behavior to seek out addictive substance
 - Poor top-down control/inhibition of drug-seeking response
- OCD
 - Habit pathway – prepotent responses to distressing stimuli must be overcome with cognitive control
- Put your favorite disorder here – chances are it involves EF deficits (see Snyder, 2016)

Phineas Gage (d. 1860)



4/10/18

COSC 494/594 CCN

6

By Jack and Beverly Wilgus, CC BY-SA 3.0,
<https://commons.wikimedia.org/w/index.php?curid=37613243>

Polygon data is generated by Database Center for Life Science, CC BY-SA
2.1 jp, <https://commons.wikimedia.org/w/index.php?curid=44466338>

Examples of Different EF Tasks

Updating: Letter Memory Task (Always Remember the Last 3 Letters)

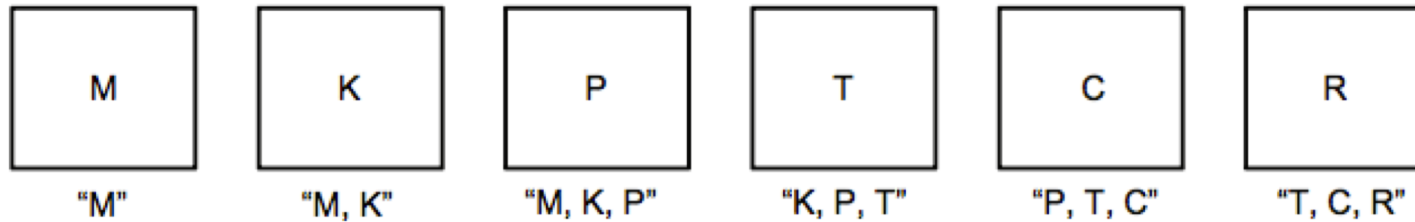

Shifting: Color-Shape Task (Classify Each Target by Color [C] or by Shape [S])

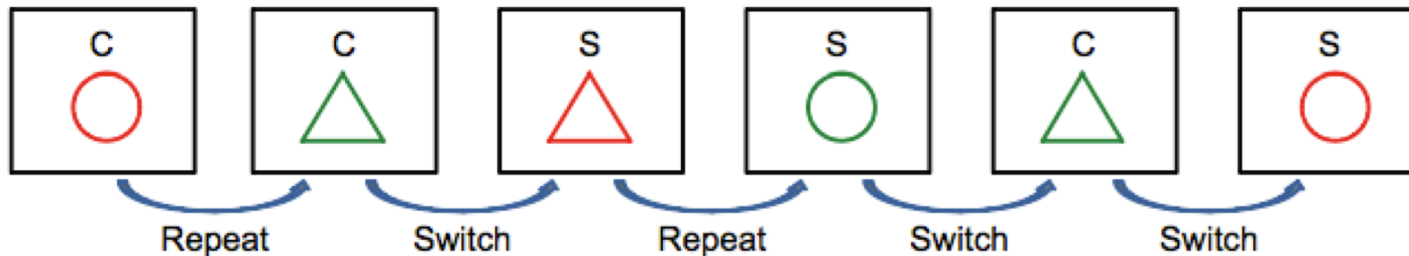

Inhibition: Antisaccade Task (Report the Arrow Direction Presented on the Nonflashed Side)

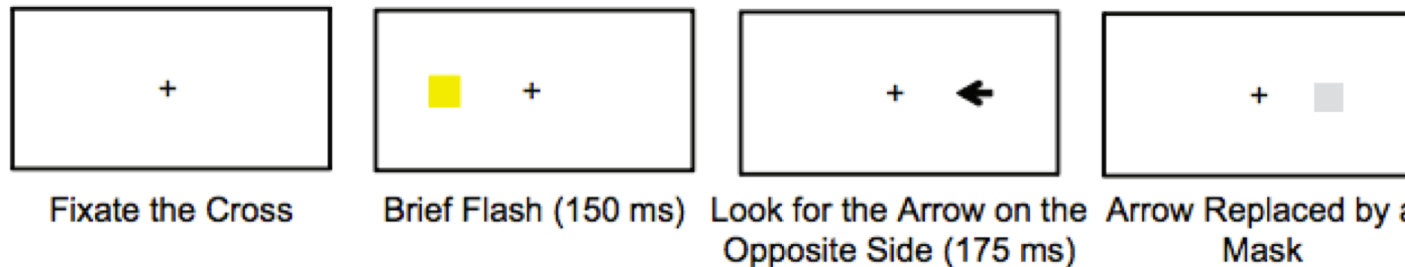

Different Parts of EF

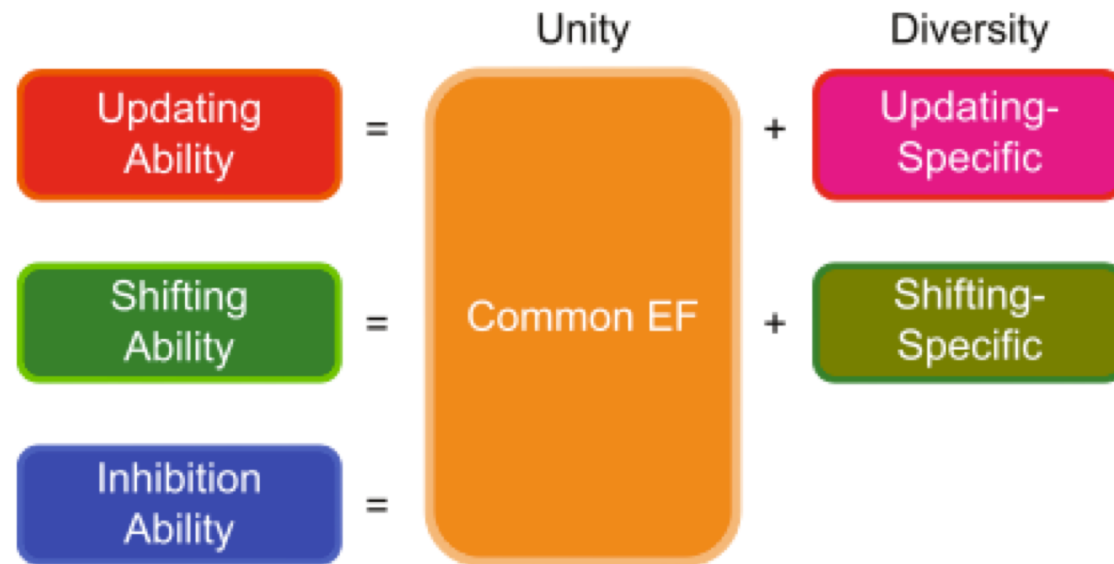

Friedman & Miyake (2012)

Prefrontal Cortex Across Species

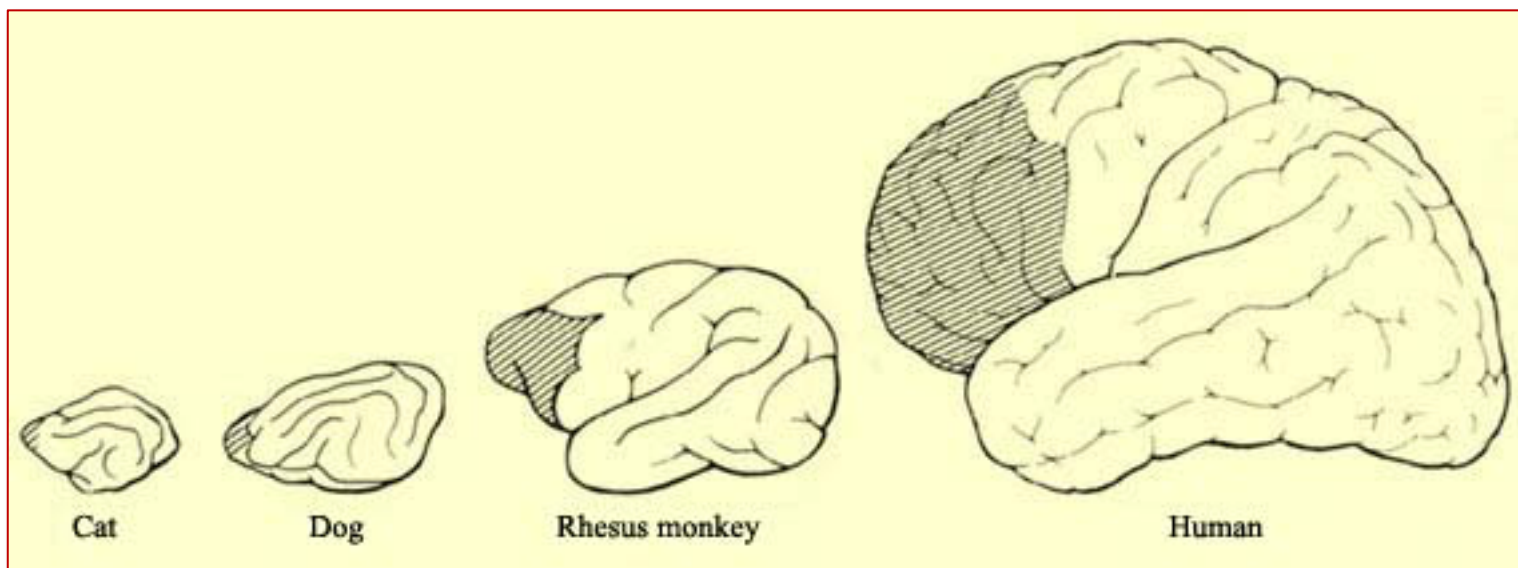
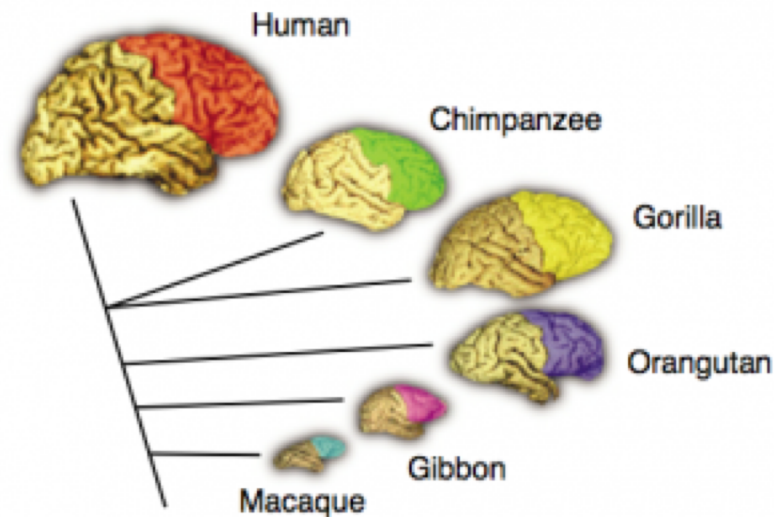

Prefrontal Cortex Across Life

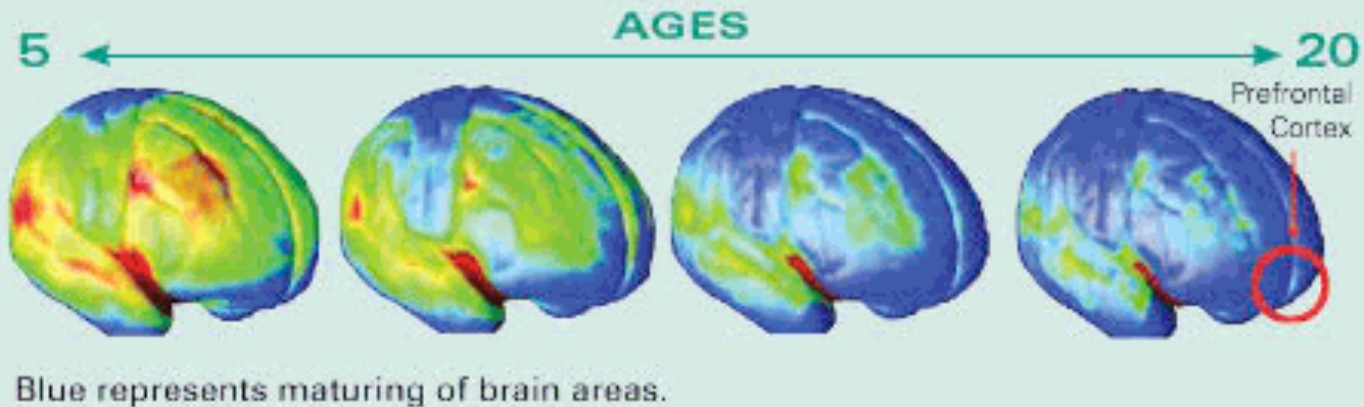

Does this development of prefrontal cortex link to impairments in decision making you may see with adolescents?

Who is in Charge of Your Brain?

Prefrontal Cortex?

Integrates:

- Cognitive Control
- Planning
- Motivation
- Reward processing
- Decision making

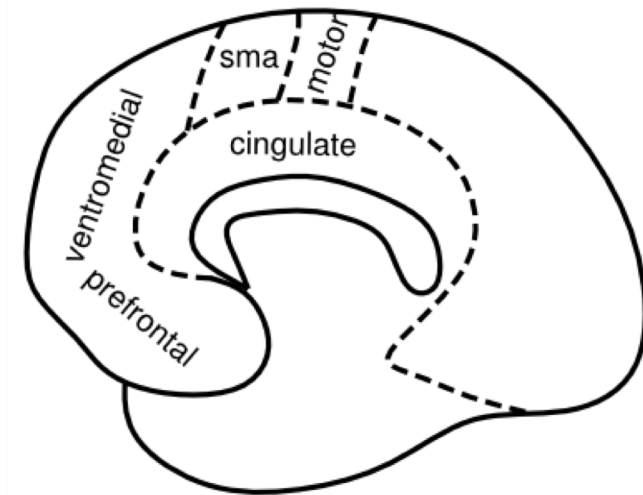
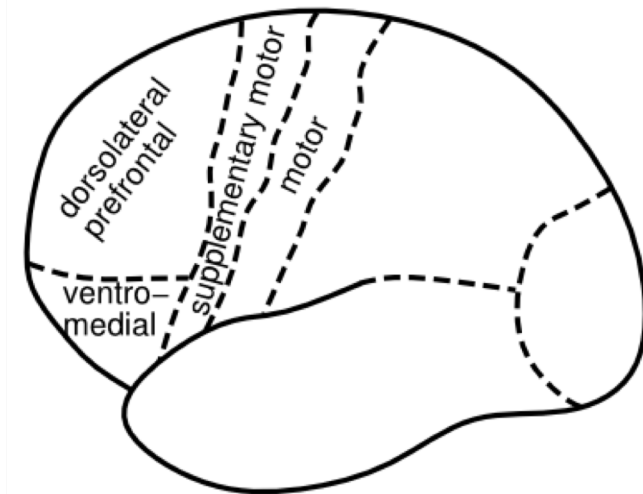

Baddeley/Hitch Model

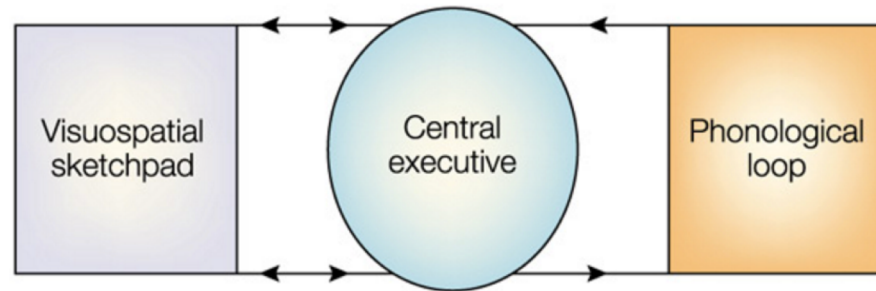

- Influential account of working memory
- Phonological loop: hold information for a few seconds, maintain through rehearsal
- Central executive: switch & focus attention
- Visuospatial sketchpad: ongoing manipulation of visual/spatial items

Key Idea: Top-Down Biasing

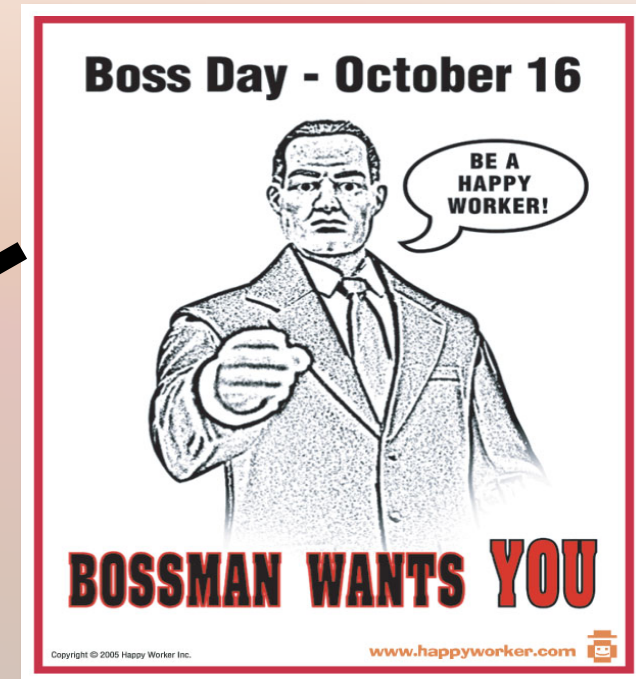

PFC active maintenance provides top-down biasing of posterior-cortical processing

The Homunculus Problem

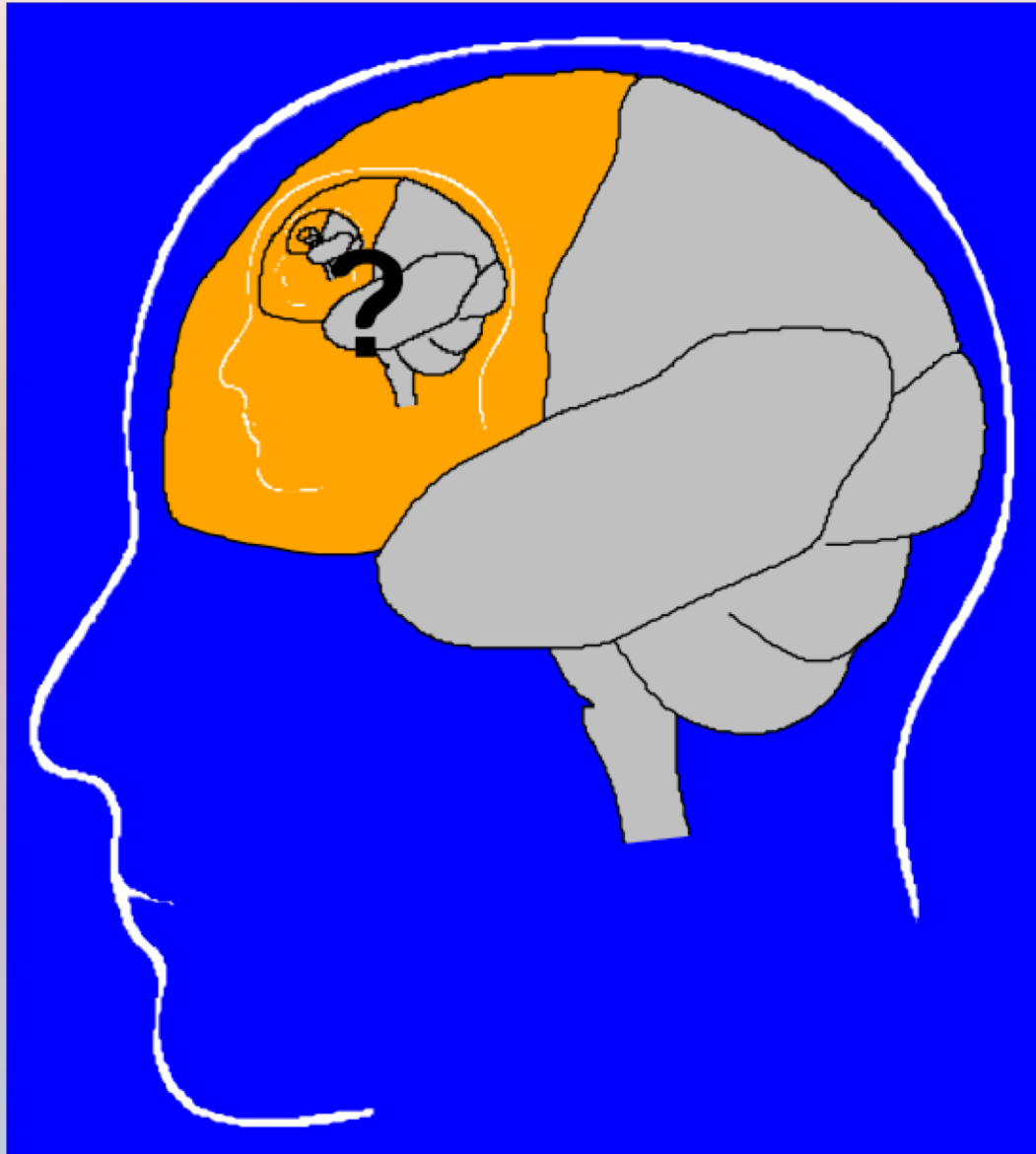

A. Biology of PFC/BG and Robust Active Maintenance

Mechanisms of “Working Memory”

It Takes a Network

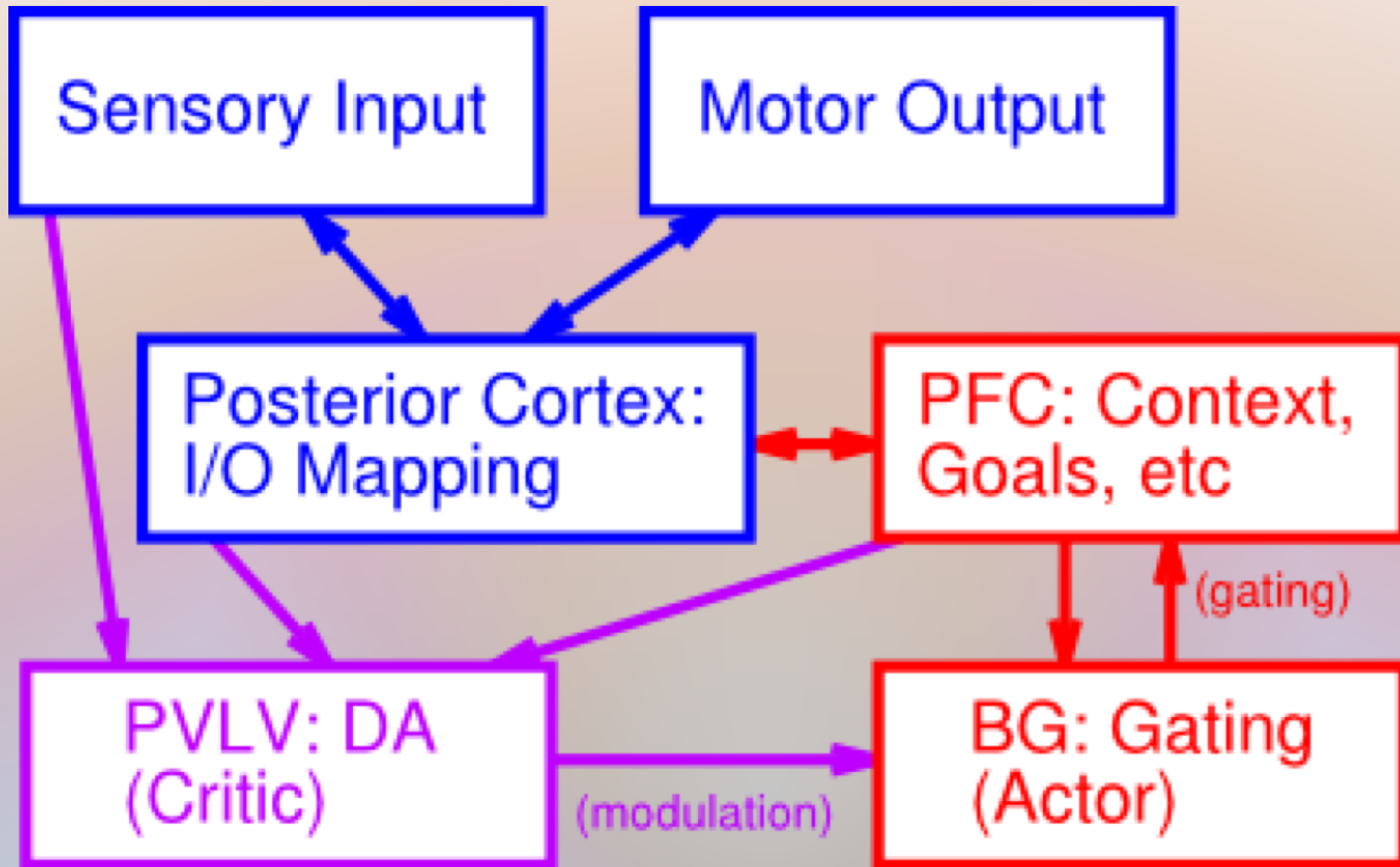

What is the PFC maintaining?

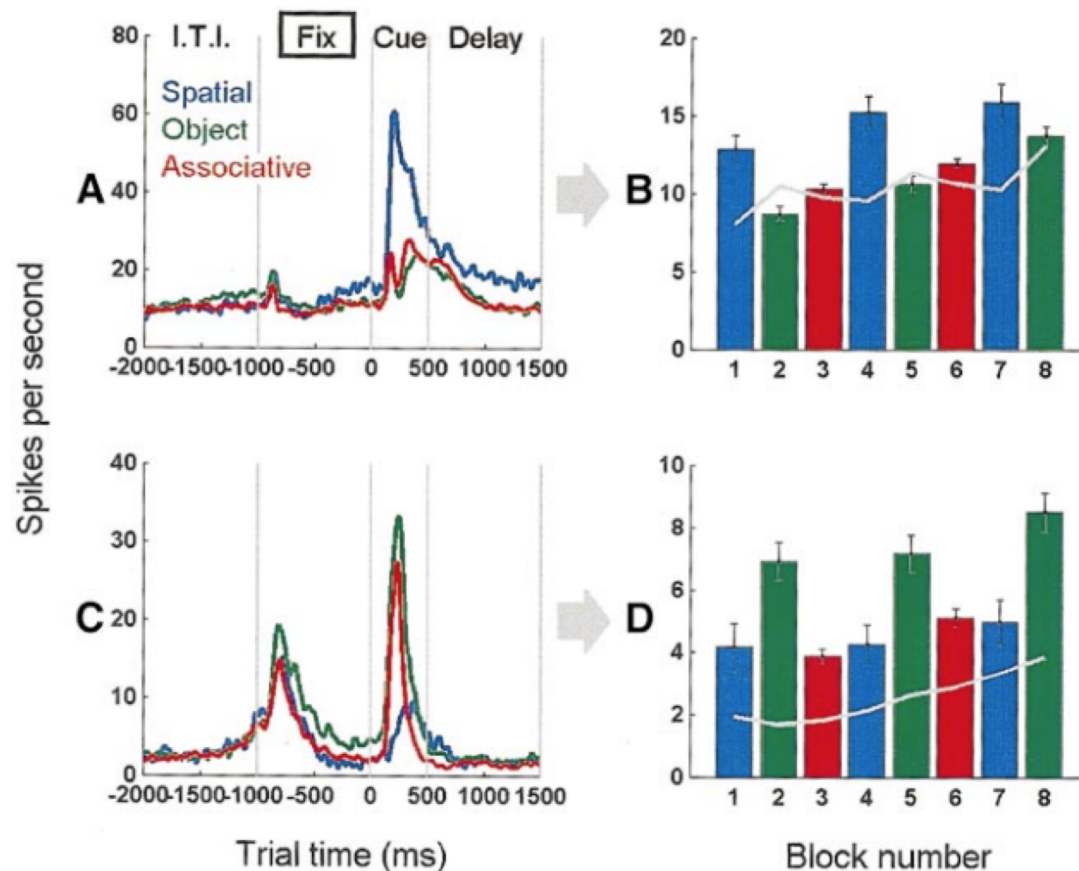

- Miller (2000) — Monkey does several different tasks
- During the delay period, you see differences in activity depending on the task, meaning that the PFC encodes “task” rules

PFC Does Active Maintenance

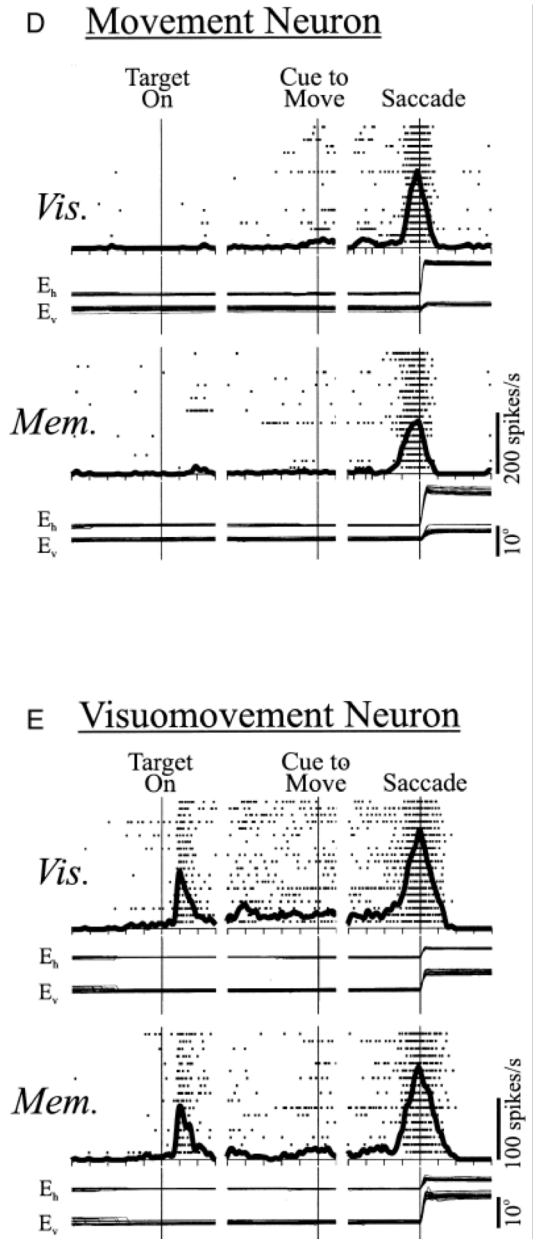
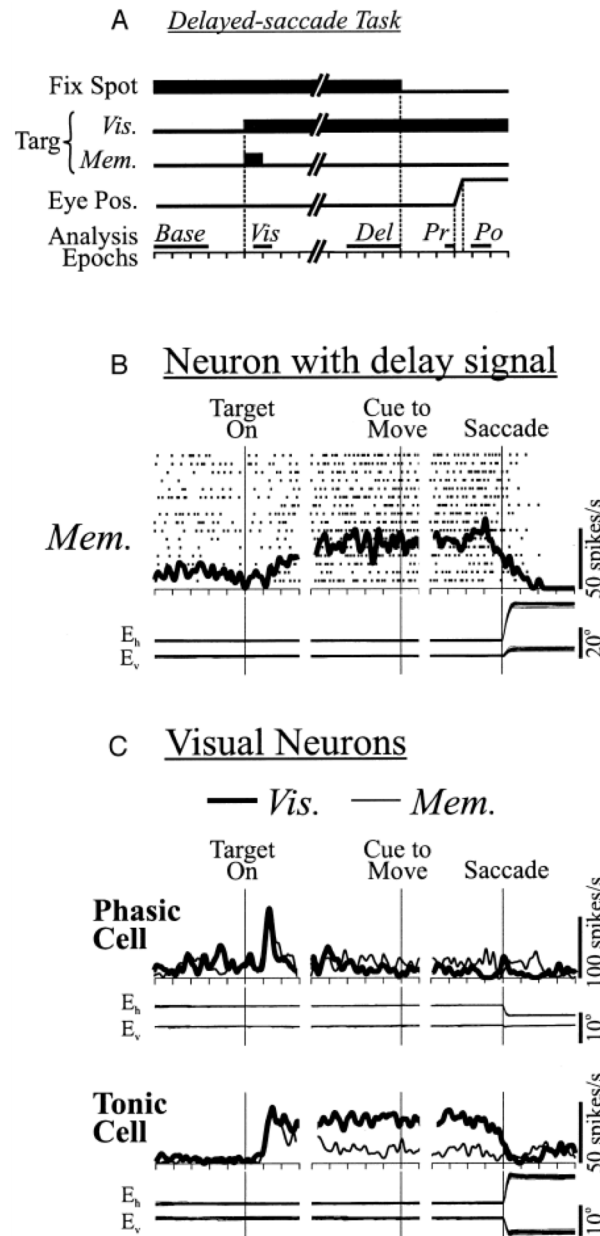

Active maintenance can do it all

- Cognitive Control
 - Maintained activity drives top-down biasing
- Planning
 - Think about things that are not there (future)
- Motivation
 - Maintain goals
- Reward processing
 - Maintain possible outcomes
- Decision making
 - Maintain alternatives

The Need for Robust Maintenance

- “Every sound has to be an earthquake or tidal wave that topples governments and changes national boundaries and mutates whole species so they suddenly drift off the planet, across galaxies, only to return, years later, when nobody wants to know them cause their credit rating’s bad or because they can’t do the Mashed Potatoes.” — MFU by HC, 1998
- Subjective experience of PFC lesion: dreaming!
— PFC is deactivated during sleep

Mechanisms of Sustained Active Firing

- Recurrent excitatory connectivity
 - corticocortical loop
 - corticothalamocortical loop
- Intrinsic excitatory maintenance currents
 - NMDA and metabotropic glutamate (mGluR) receptors
 - once opened by high frequency activity, provide longer window of increased excitability

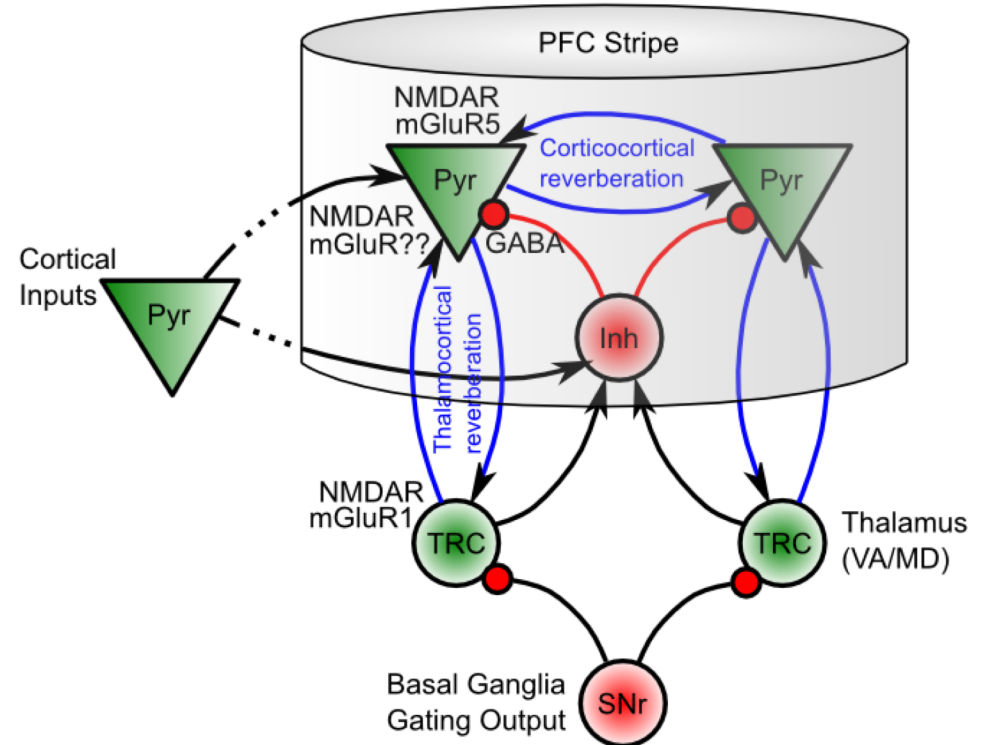

Functional Specialization of PFC Areas

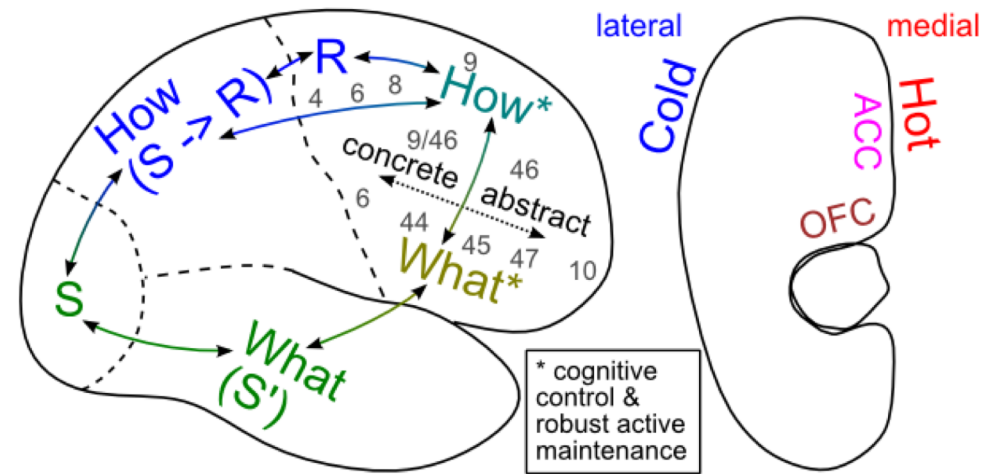

- Lateral: “cold” cognitive processing (sensory & motor areas)
 - Dorsal lateral PFC (DLPFC): executive control over motor planning & control
 - Ventral lateral PFC (VLPFC): control over temporal lobe pathways that identify entities and form semantic associations
- Medial: “hot” emotional & motivational processing (subcortical areas)
 - Dorsal medial PFC (DMPFC): encodes affective aspects of motor control variables
 - Ventral medial PFC (VMPFC) including orbital frontal cortex (OFC): encodes affective value of sensory stimuli

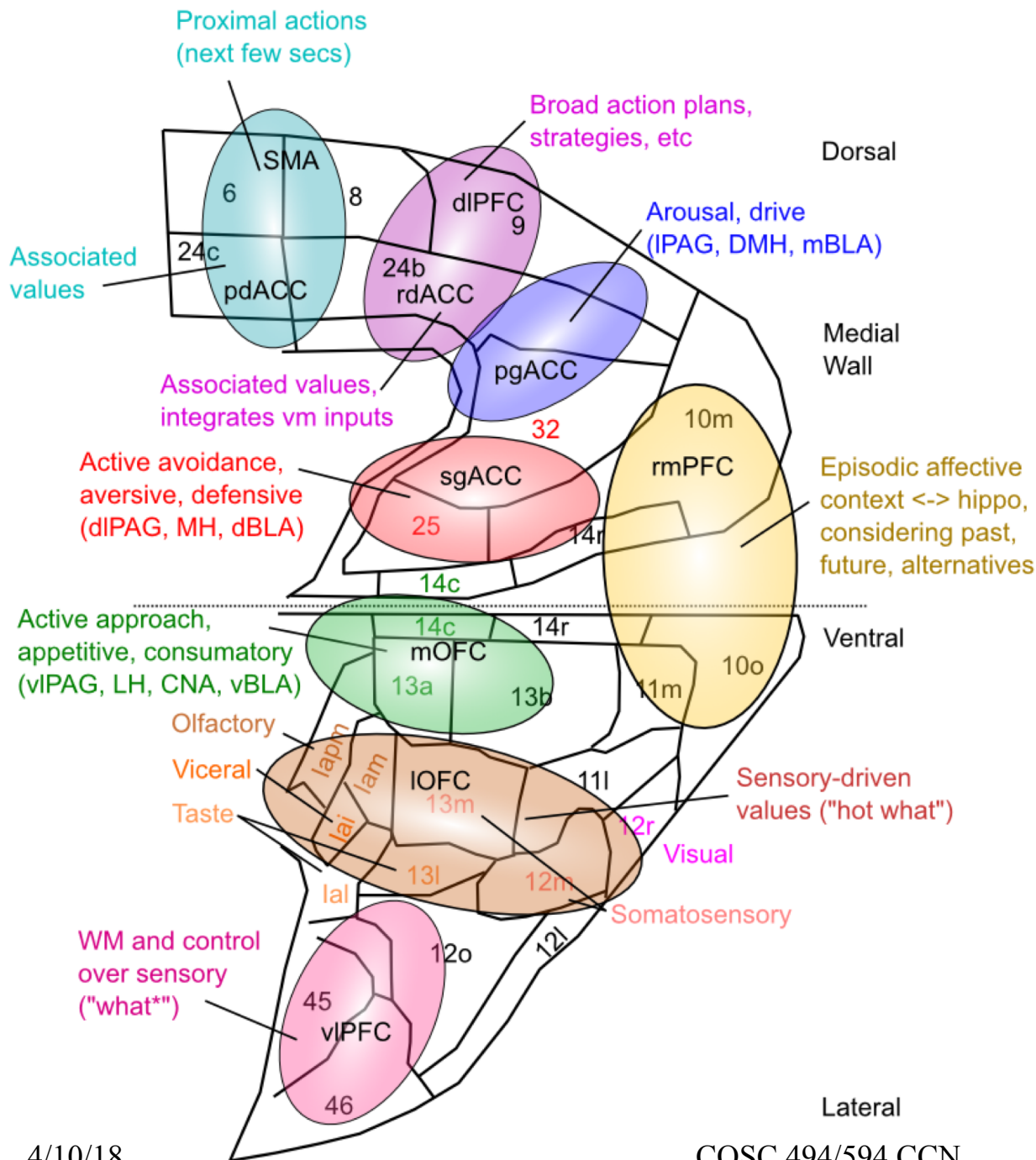

Medial Frontal Map of Values

This is your emotional life

Orbital Frontal Cortex (OFC)

- OFC abstracts the mores of one's culture
 - abstracts “rules” (regularities) of social interaction
 - prior to moral reasoning (reflection comes later)
 - similar to brain's abstraction of language regularities
 - both are regularities in our social interactions
- OFC guides behavior in accord with cultural mores
 - following mores activates endogenous reward system (and vice versa)
 - emotional judgements of morality
 - OFC and related limbic areas are especially active in moral personal dilemmas

Patient “Eliot”

- Patient of Antonio Damasio (*Descartes' Error*)
- Damage to both PFC (cf. Phineas Gage)
 - they both became obsessive collectors
- Eliot lost *feelings* (capacity to experience emotions)
 - remembered them & understood them intellectually
 - could not make rational decisions
 - could do the analysis
 - could not weigh options and make a choice
- Emotions are an essential foundation for rational behavior

Substructure of PFC Areas

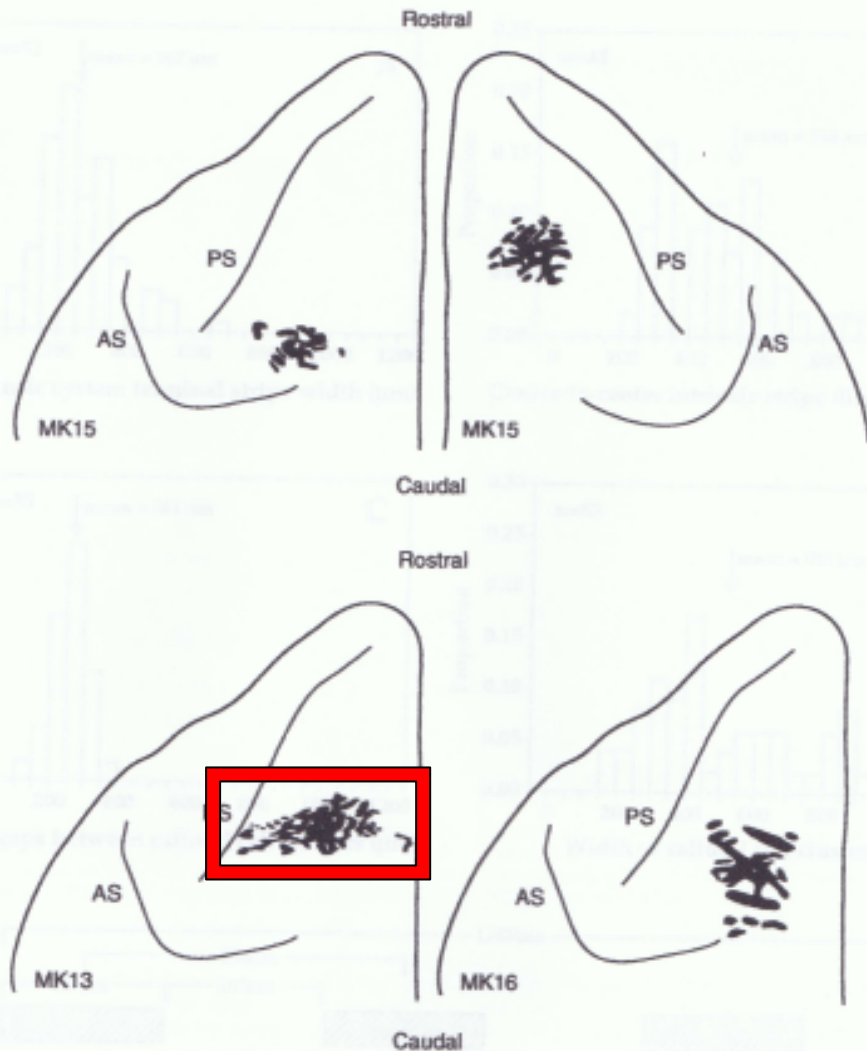

- PFC organized into stripes (= macrocolumns, hypercolumns)
- Stripes are organized into clusters of about 10
-  four clusters in monkey PFC
- ~20 000 stripes in human FC

PFC Stripe Cluster

- Microcolumn:
 - ~50 pyramidal cells
 - ~50 microns across
 - correspond to rate-coded model neurons
- Stripe:
 - ~100 microcolumns
 - 5×20 microcolumns
 - $0.25 \times 1 \text{ mm}^2$

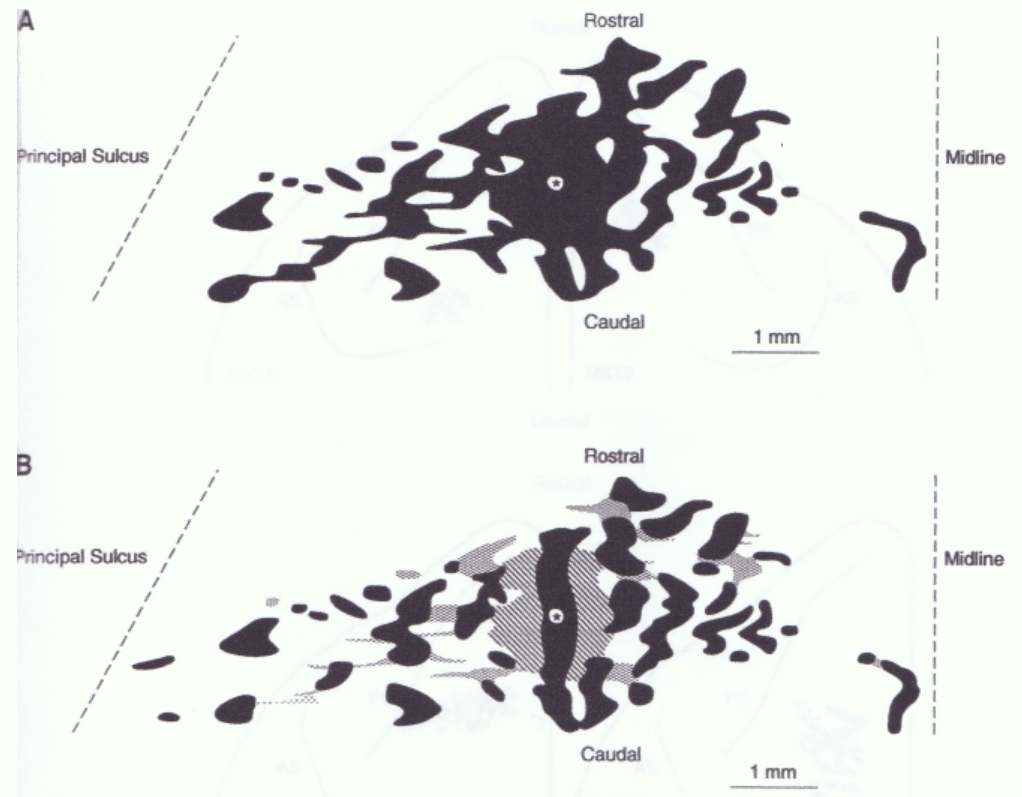

- Hypothesis: individual stripes updated by loops through BG
- Lower figure (B) shows two stripe clusters

BG Model Extension to Working Memory and Attention

- In the motor domain, the BG selectively facilitates one command while suppressing others (Mink, 1996)
- In parallel circuits, the BG may reinforce the updating of PFC working memory representations (Alexander et al, 1986; Frank, Loughry & O'Reilly, 2001)
- Dopamine (DA) in PFC supports robust maintenance over time (Lewis & O'Donnell, 2000; Durstewitz & Seemans, 2002)
- Phasic DA bursts thought to occur for task-relevant (“positive”) information, reinforcing BG updating signals (O'Reilly & Frank, 2006; Frank & O'Reilly, 2006)
- Time course of DA activity: maintenance in PFC, updating thru BG

Basal Ganglia and Dynamic Gating

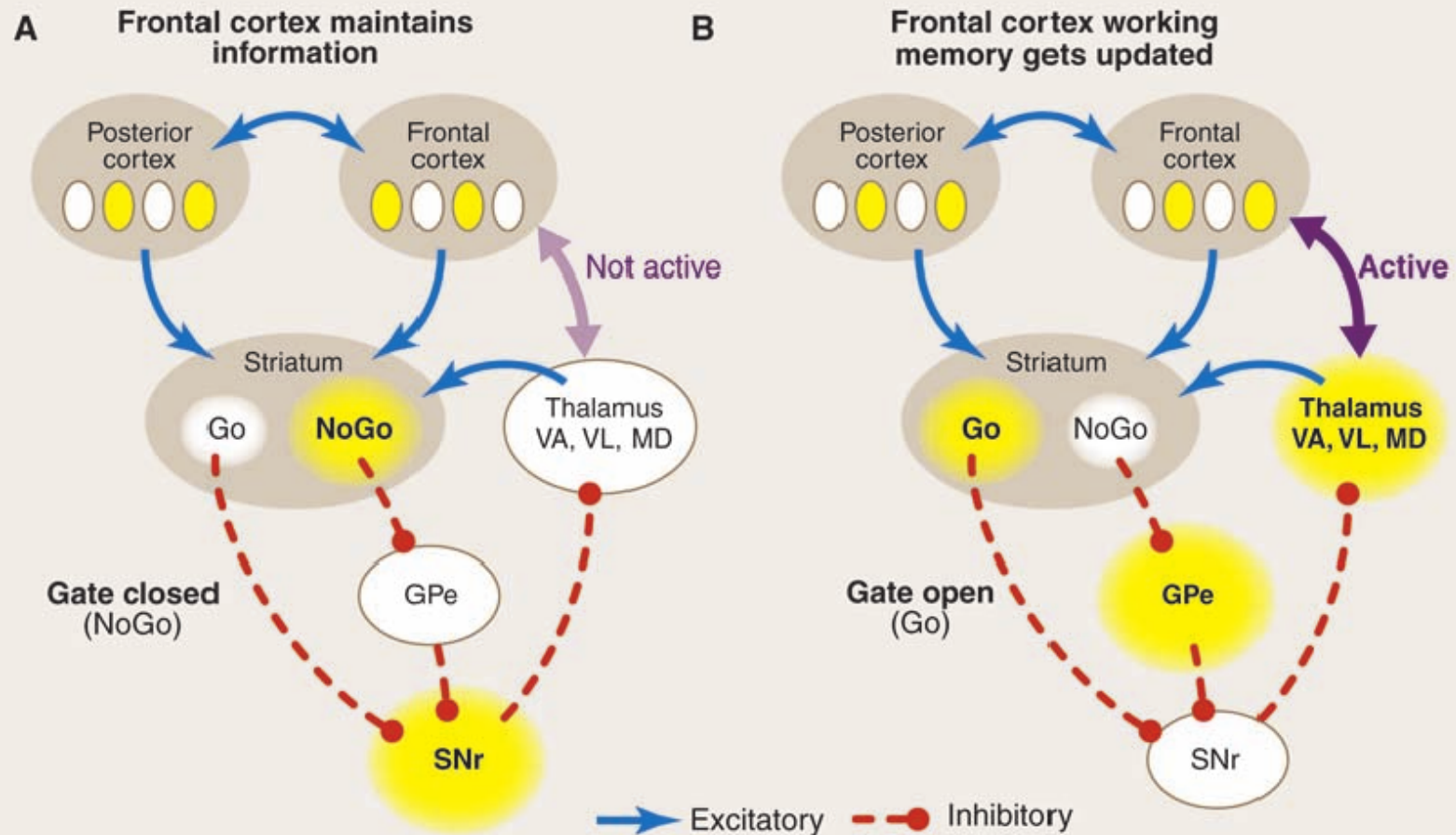

- (A) Default state, no BG activity or NoGo firing: PFC continues to maintain information in active state. SNr or GPi exhibits tonic activity, inhibits neurons in thalamus, shutting down thalamocortical loop
- (B) Go firing triggers updating of PFC stripe to encode new information by inhibiting SNr/GPi neurons, opening up thalamocortical loop, resulting in activity in PFC that drives updating to new pattern of firing, including intrinsic maintenance currents to sustain new pattern

Phasic DA & Temporal Credit Assignment

- How does PFC active maintenance system learn what to maintain?
- Initially dopamine (DA) neurons respond to primary rewards
- Later respond to conditioned stimulus (CS) to predict rewards
- Maintenance of useful information in PFC acts as CS, predicting reward
- Phasic DA signal at CS onset drives learning of BG Go neurons that update new information into PFC active maintenance

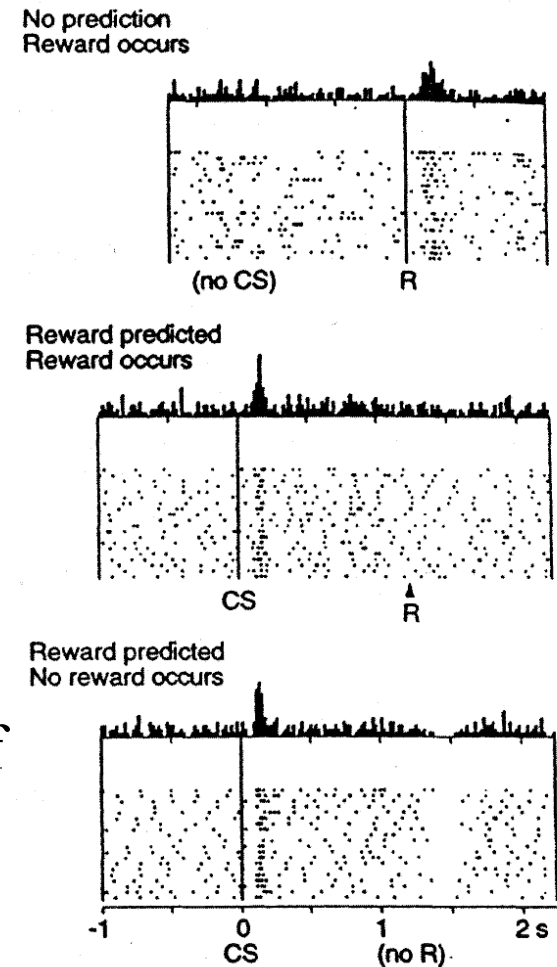

B. The PBWM Computational Model

Prefrontal Cortex Basal Ganglia Working Memory

Motor Gating \Rightarrow Cognitive Gating

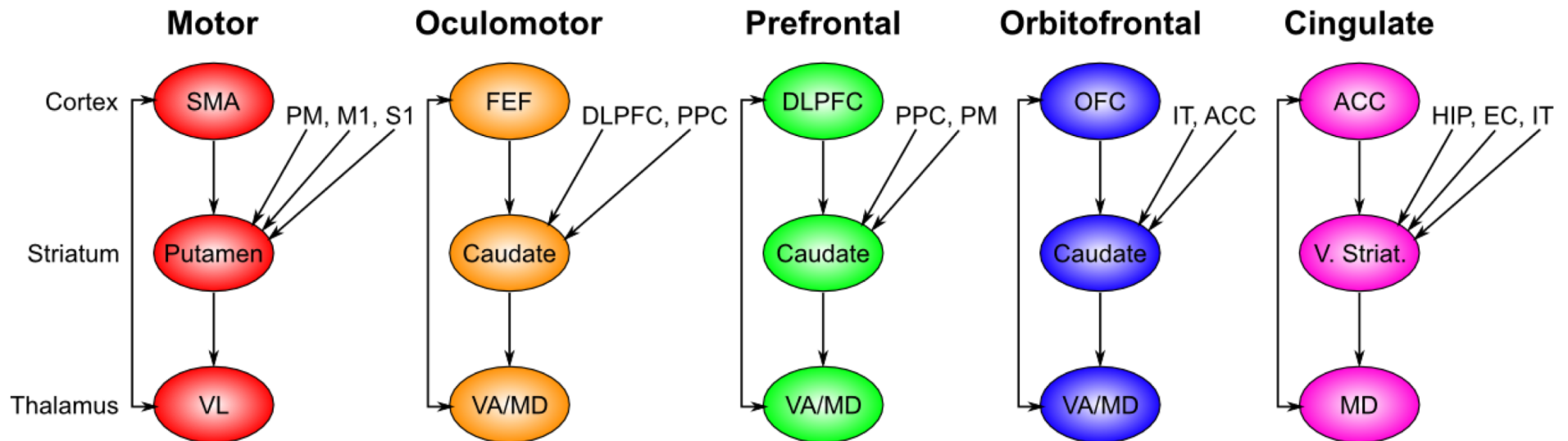
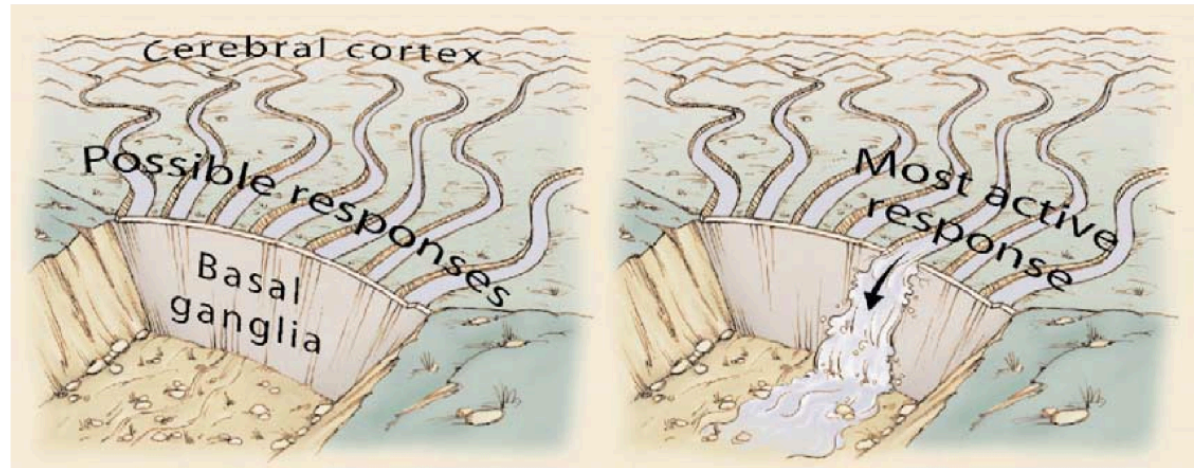

Chain of Command

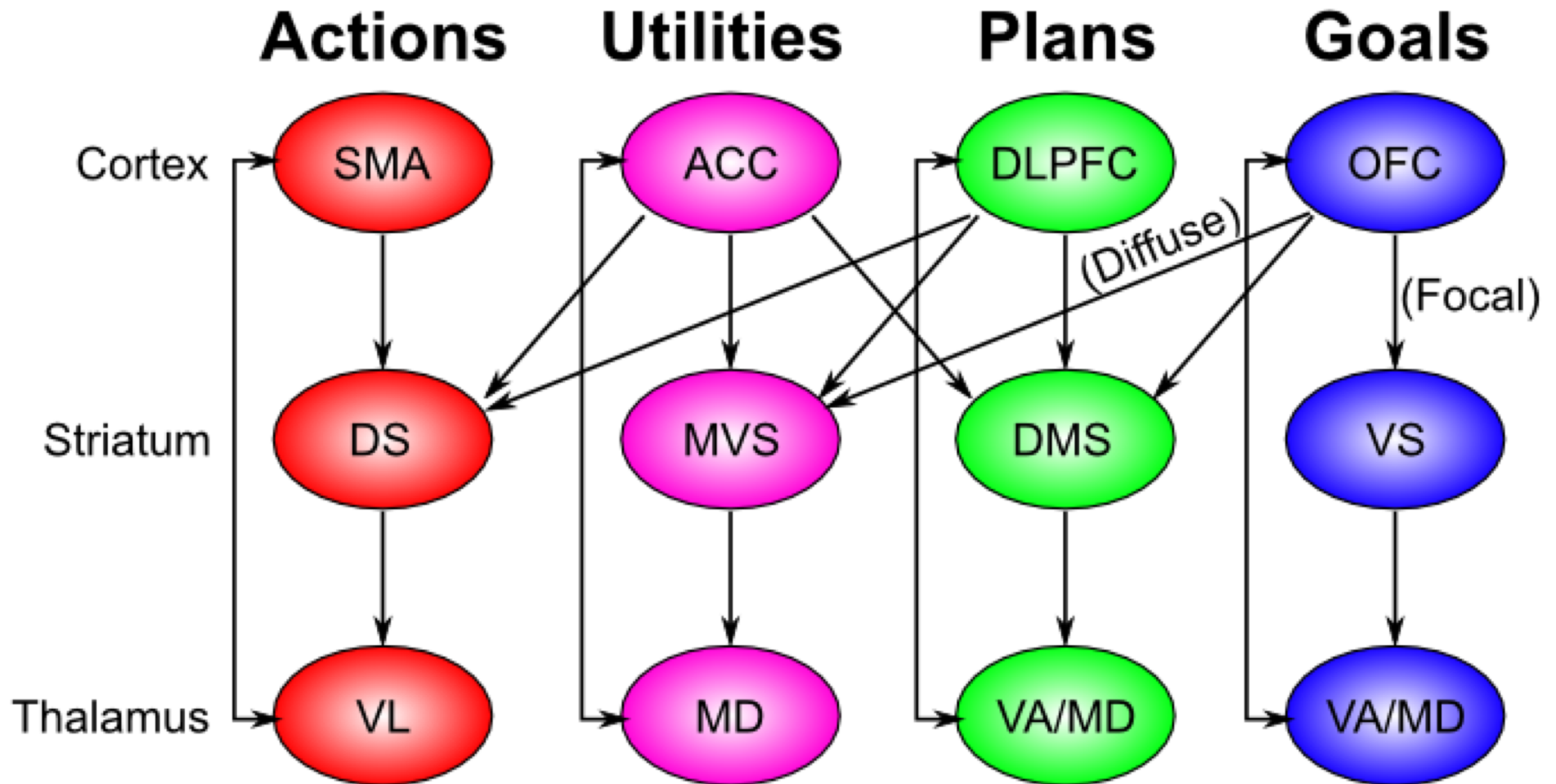

PBWM Model

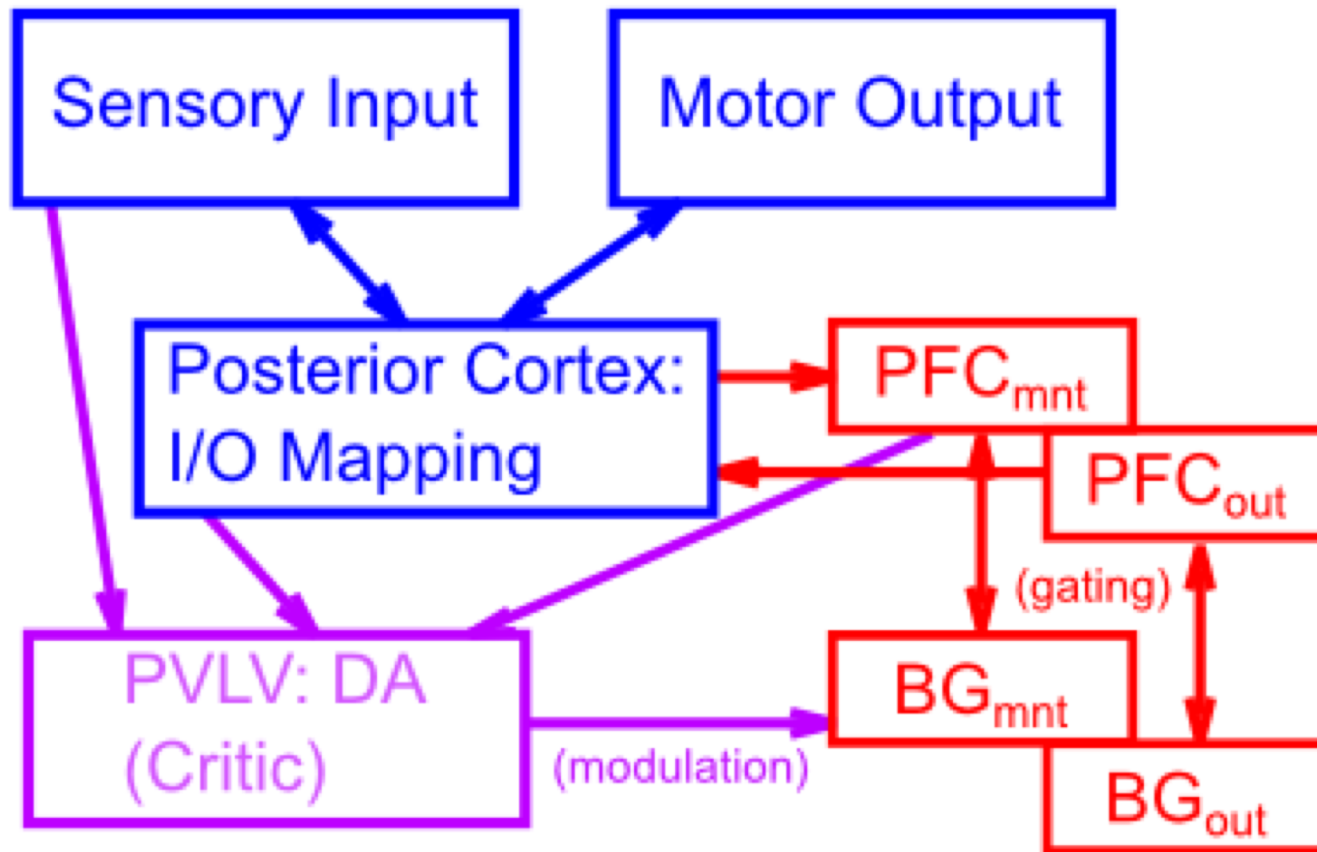

BG Gates Flow: Superficial → Deep PFC

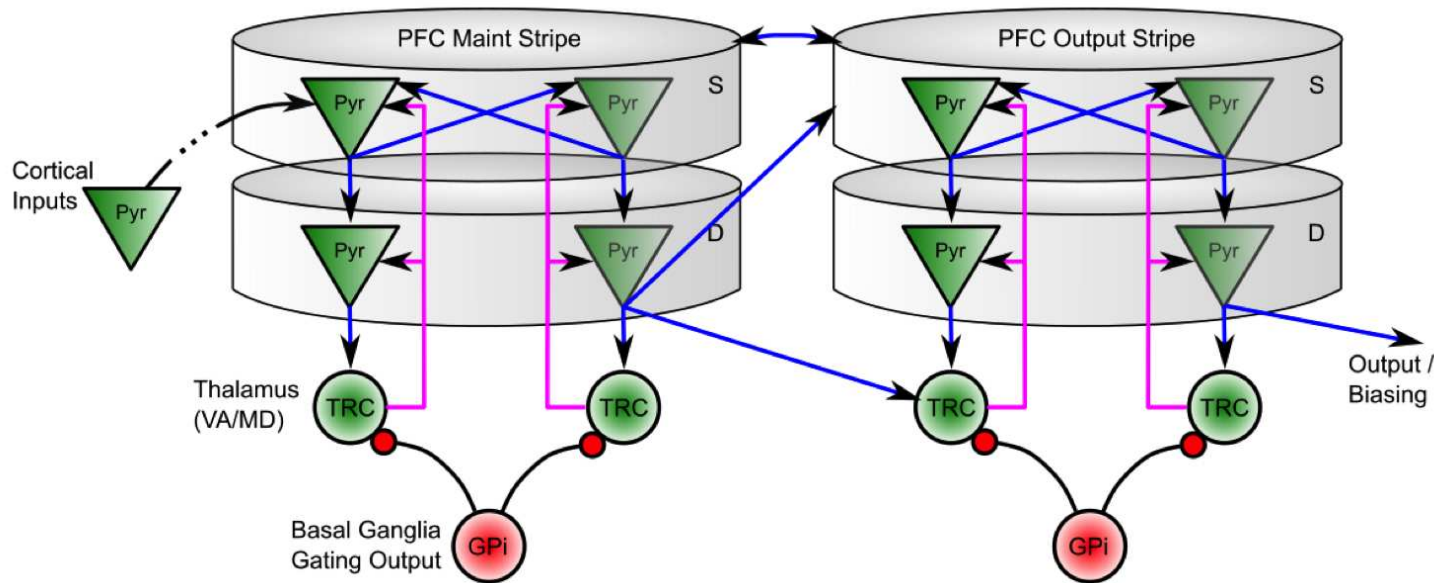

- Maintenance via thalamocortical loops, BG disinhibits
- Superficial reflects inputs and maintenance
- Separate Maintenance vs. Output PFC / BG stripes

Details: Maintenance vs. Output

A - Maintenance, pre-Output

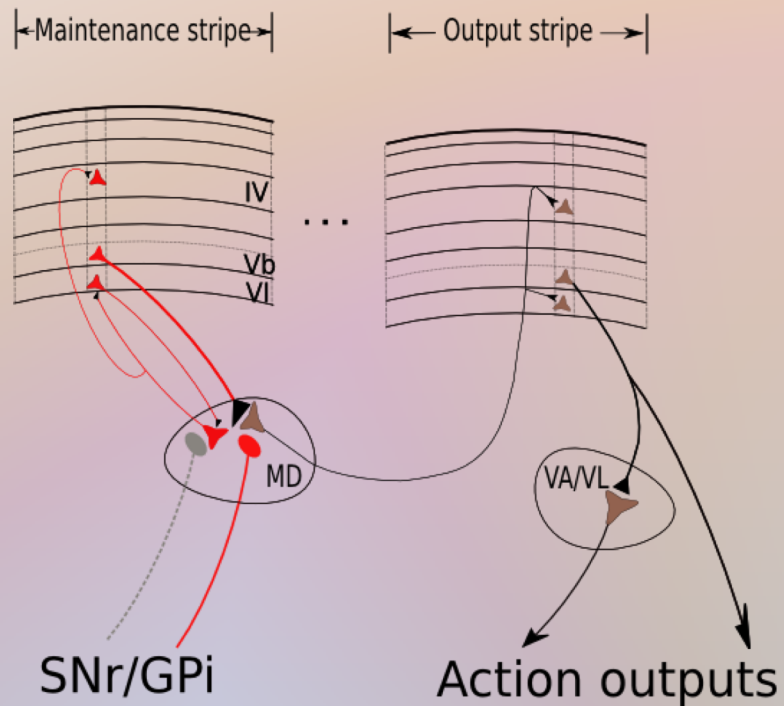

B - Output gating

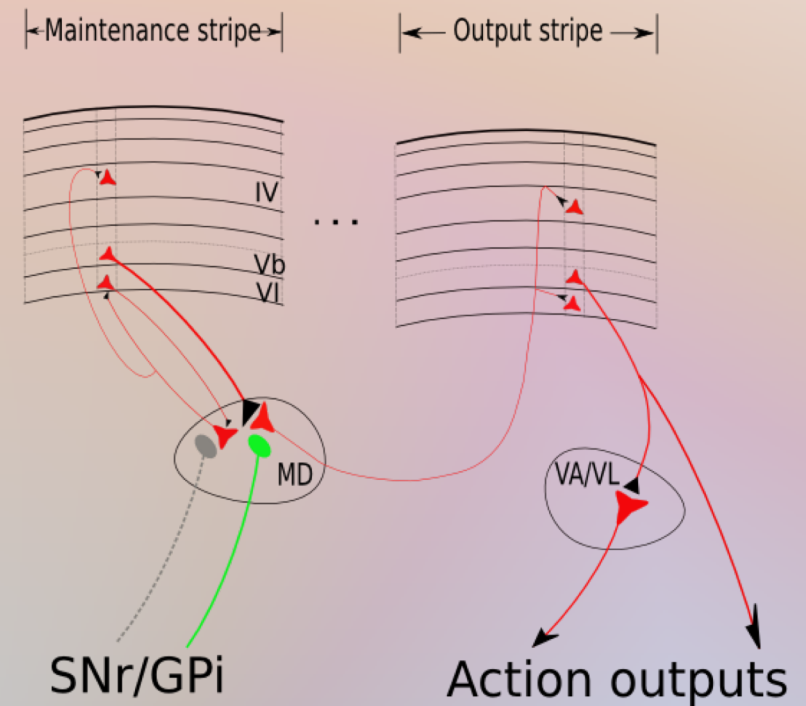

Trace-based Learning

- System uses trial and error exploration of different gating strategies in the BG
 - DA reinforces strategies associated with positive reward
 - DA punishes those that are not
- Synaptic-tag-based trace mechanism
 - reinforces/punishes all prior gating actions leading to DA outcome
- When a matrix unit in BG fires for a gated action
 - synapses with active input establish a synaptic tag
 - which persists until subsequent phasic DA outcome signal
- Synaptic tags based on actin fiber networks in the synapse
 - can persist for up to 90 minutes
 - when subsequent strong learning event occurs, tagged synapses are also strongly potentiated

Parallel Stripes for Selective Gating

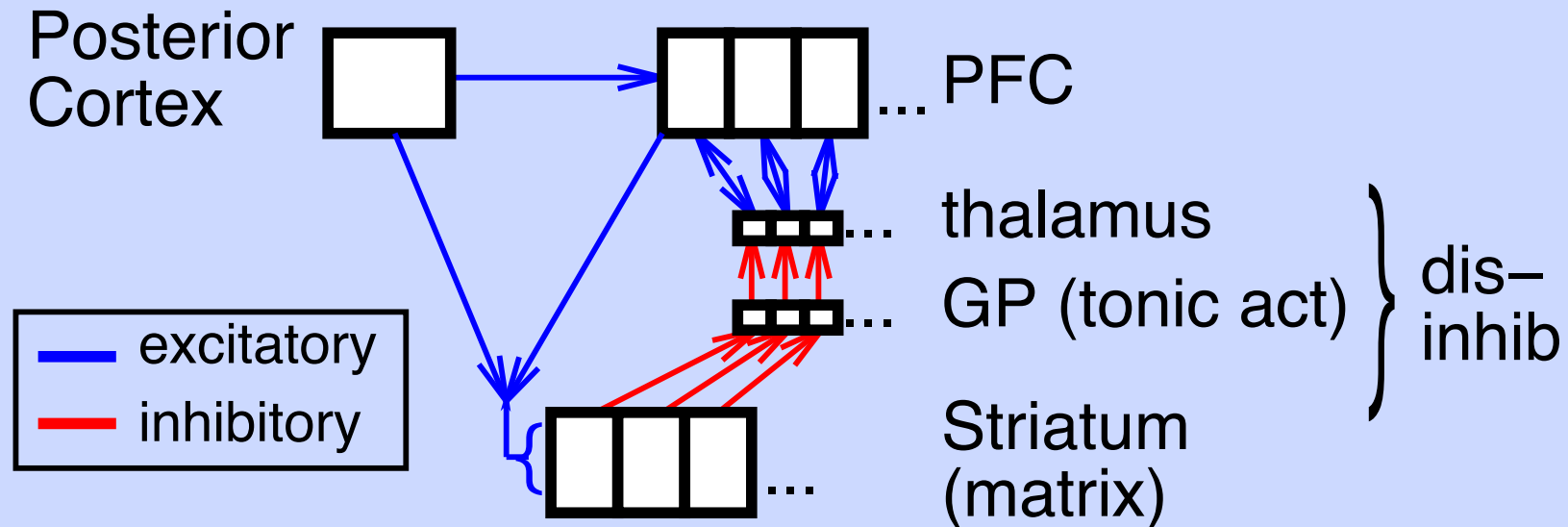

- PFC/BG loops form independent stripes = selective gating
- Different gating strategies to be explored in parallel
- Multiple stripes are critical when more than one piece of information has to be maintained and updated

Multiple Stripes: Competition

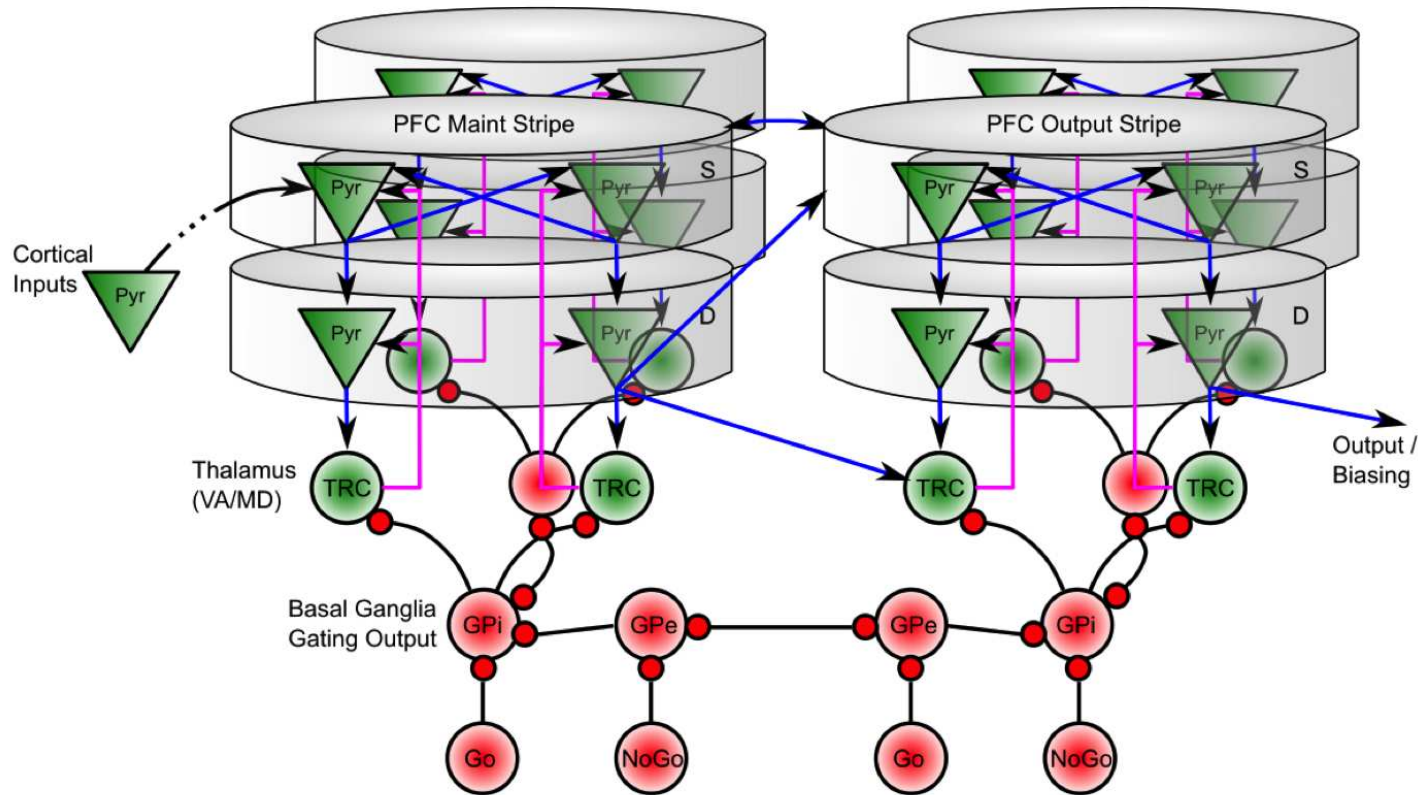

Competition in striatum/GP between Maint vs. Output and different stripes

C. Top-down Control

Stroop Task: Top Down Biasing

RED

Stroop Task: Top Down Biasing

GREEN

Stroop Task: Top Down Biasing

RED

Stroop Task: Top Down Biasing

GREEN

Conditions

- Control: no color unit active
- Conflict: color of word inconsistent with meaning
- Congruent: color of word consistent with meaning

Asymmetric Conflict

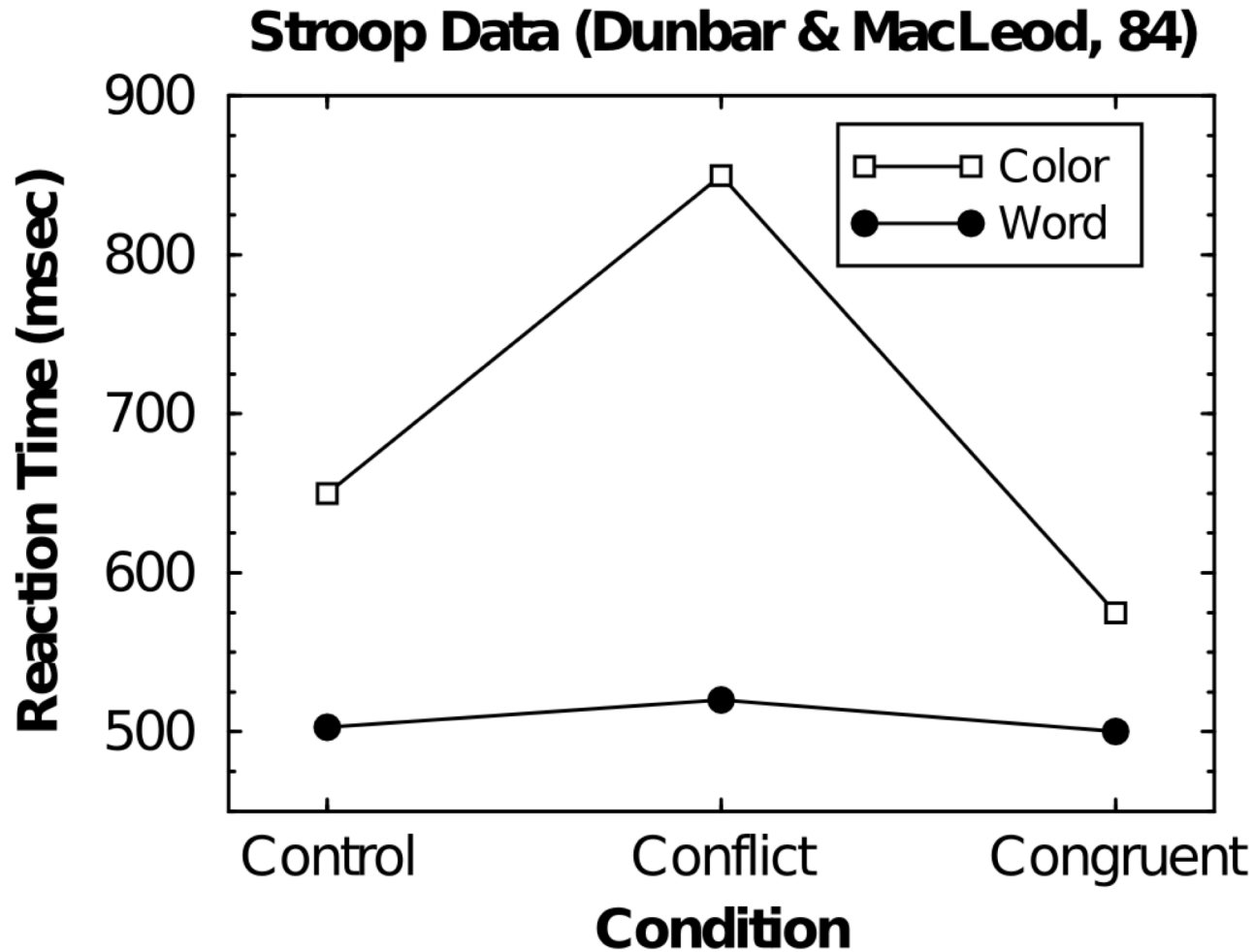

Stroop Effect: *GREEN*

Possible explanation: **differential pathway strength:**

- Two pathways: word reading and color naming
- These **compete** to generate response
- Word reading pathway is much stronger than color naming
- When word identity information doesn't match color, it **interferes strongly** with color naming
- Because color pathway is relatively weak, incongruent color information does not interfere with word reading

Stroop Effect: *GREEN*

- Puzzle: If the color naming pathway is weaker than word reading, how do we manage to name color of the word “green” above?
- Solution: Prefrontal cortex actively maintains a representation of the task that you are supposed to be doing (color naming or word reading)
- This actively maintained task representation biases processing in posterior cortex by activating units in the appropriate pathway
- e.g., color naming task representation in PFC sends activation to the units in color naming pathway

Model of the Stroop Task

A PDP MODEL OF TASK SWITCHING

9

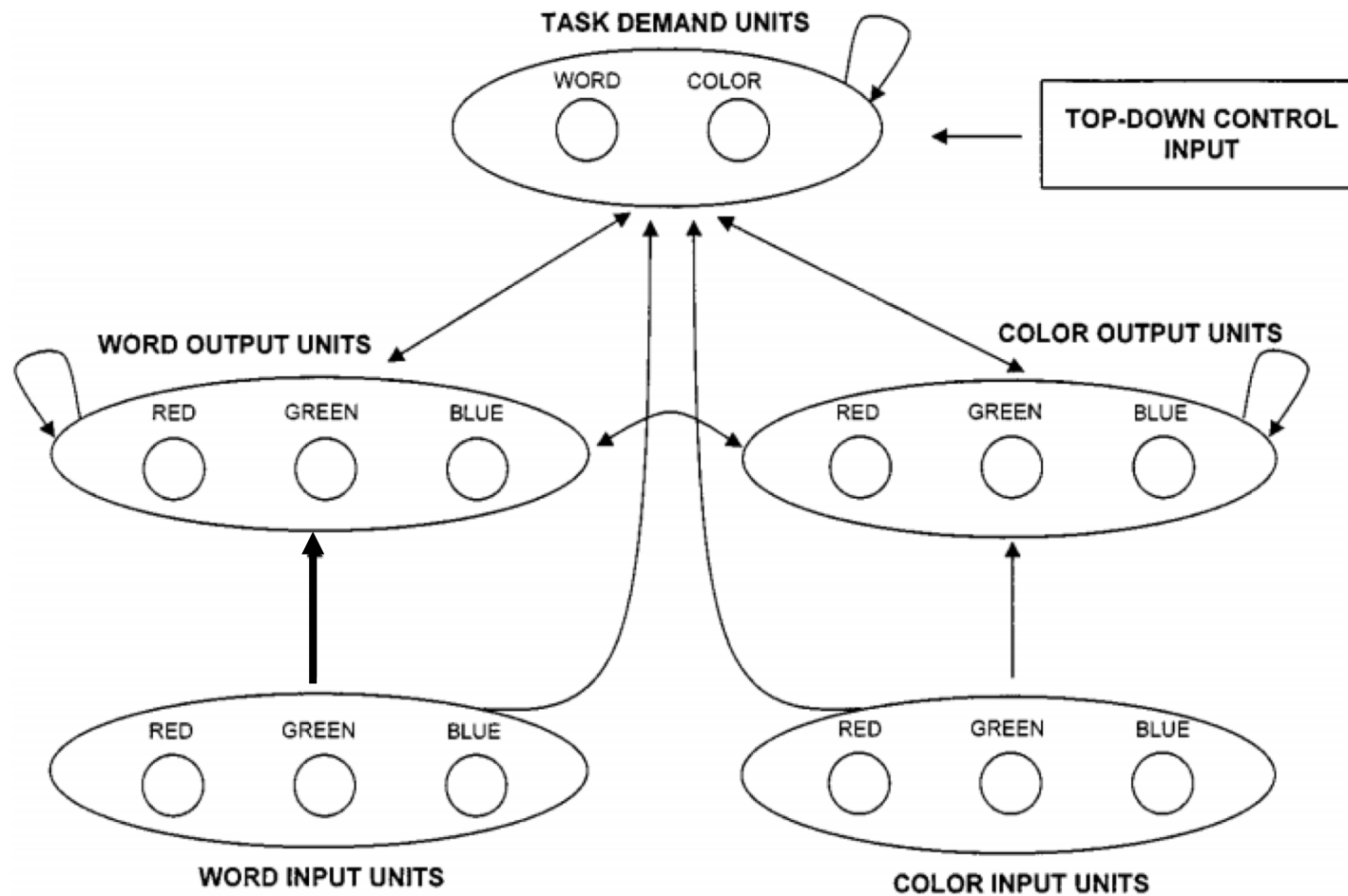

FIG. 2. Architecture of the present model.

Effects of Frontal Damage

- Assess importance of prefrontal (PFC) task units in the model
- Weakened connection strength \Rightarrow much slower in conflict color naming condition
- Same pattern of data observed in frontal and schizophrenic patient populations
- PFC task units are important for controlled-processing necessary to overcome prepotent word reading response
- However, other manipulations could cause this same pattern of behavior without specifically affecting PFC

SOA Timing Data

- SOA = stimulus onset asynchrony
 - in word reading: time by which color precedes (-) or follows (+) word
 - in color naming: time by which word precedes (-) or follow (+) color
- Word reading is relatively impervious to color conditions
- Elimination of interference effect of words on color naming when color precedes word by long time
- Model duplicates these effects except:
 - processing is slowed across all conditions as the two inputs get closer to being presented simultaneously
 - increasingly large interference effect for earlier word SOA's on color naming in the model, but not in people

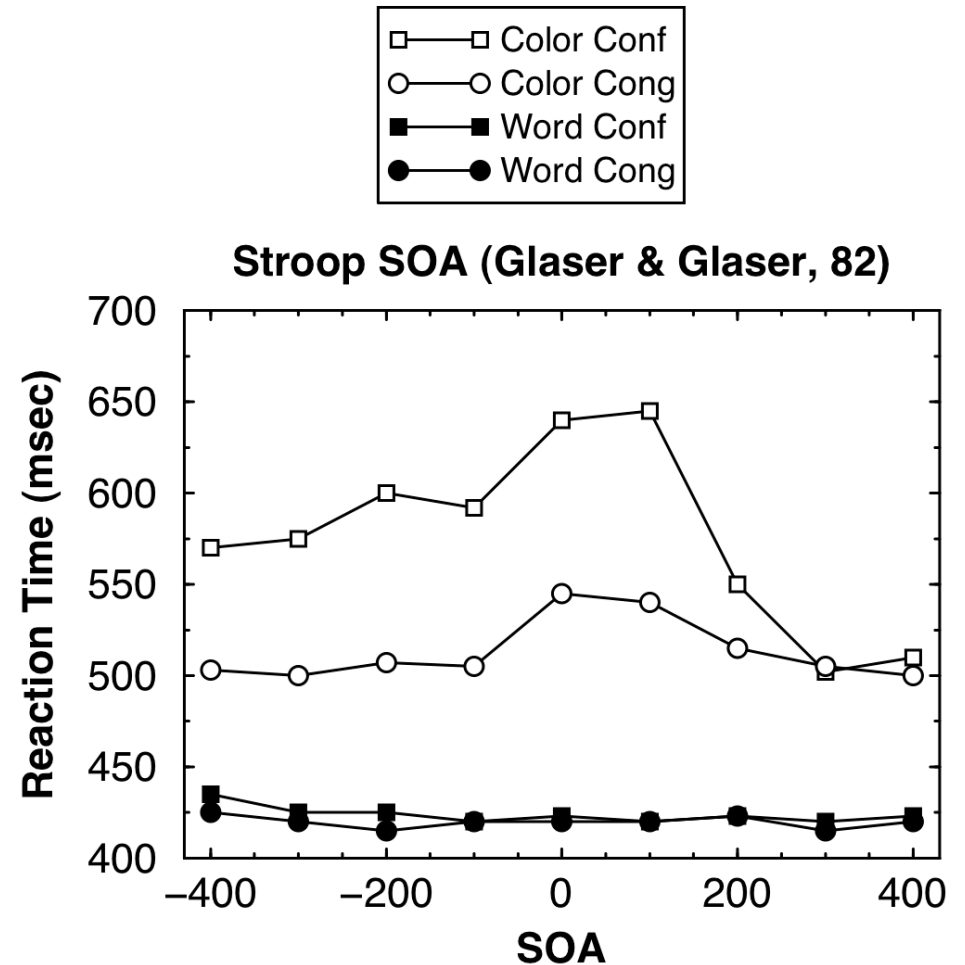

emergent Demonstration: stroop

Development of PFC Active Memory Strength

- Piaget's A-not-B task:
 - toy hidden several time in location A
 - toy hidden in different location B
 - child looks for toy in location A
- Captured by “A Not B” model
 - development modeled by increasing strength of reverberant excitatory connections among PFC neurons
 - improves active maintenance, so “older” networks can hold onto information for longer period of time

“A Not B” Model

- Inputs:
 - Location: 3 possible
 - Cover: 2 cover types
 - Toy: 2 toy types
- Hidden: represents PFC
- Outputs:
 - Gaze: updated continuously
 - Reach: has to wait

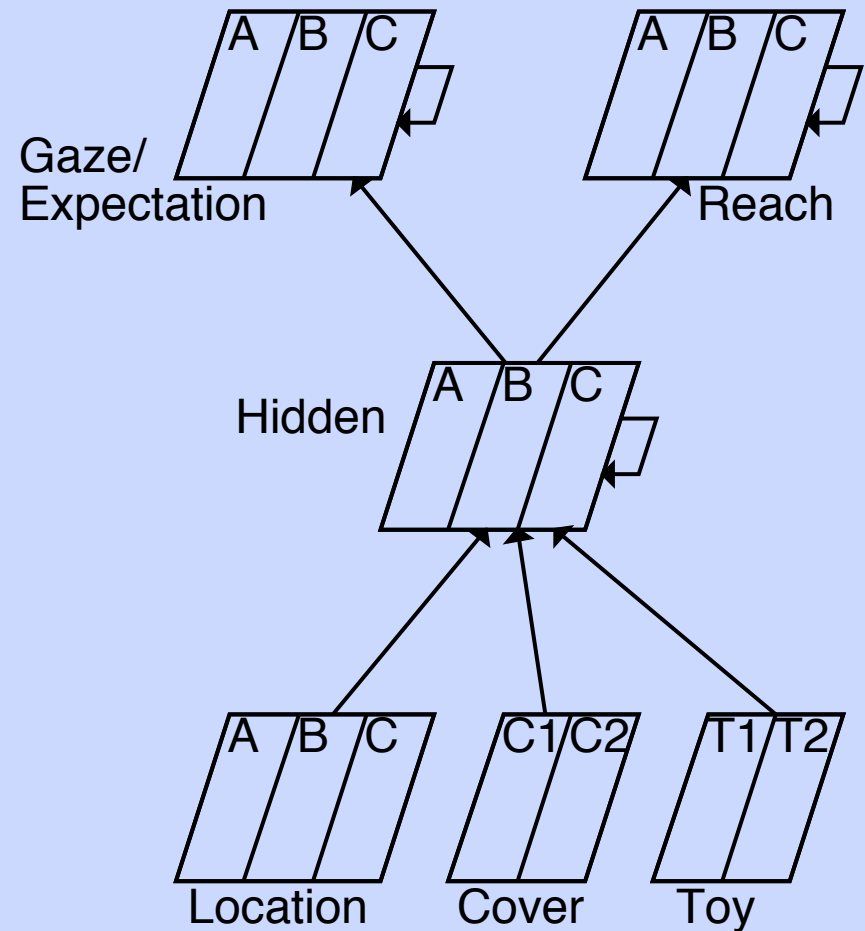

Trials

1. start: covers sit in place on apparatus, before experimenter draws infant's attention to particular location
 - weak equal activation on locations and cover inputs
2. toy presentation (toy-pres): experimenter draws infant's attention to and places it into one location
 - one location more strongly active, and toy T1 active
3. lid presentation (lid-pres): experimenter further draws infant's attention to the location while placing lid over the toy location
 - toy fading out in activation while cover is more active, and location less active
4. delay: the apparatus sits with all covers in place
 - equal weak location and toy activation
5. choice: experimenter makes apparatus accessible (with covers in place) for infant's response (reaching is possible/permitted only during this segment)
 - inputs more active than delay but same pattern; reach layer is disinhibited

emergent Demonstration: A Not B

Dynamic Updating of PFC Active Memory: The SIR Model

- SIR (Store, Ignore, Recall) task. Example sequence:
 - *S* - *A* — this means that the network should store the *A* stimulus for later recall — network responds *A*
 - *I* - *C* — ignore the *C* stimulus, but you still have to respond to it — network responds *C*
 - *I* - *B* — ignore the *B* stimulus — network responds *B*
 - *R* — recall the most recently stored stimulus — network responds *A*
- BG has to learn:
 - to fire *Go* to drive updating of PFC on Store trials
 - to fire *NoGo* to ignore stimuli, so don't overwrite previously information
 - on recall trials, output BG gating mechanism should drive output of stored information
- Network starts out knowing nothing about semantics of various inputs

SIR Model

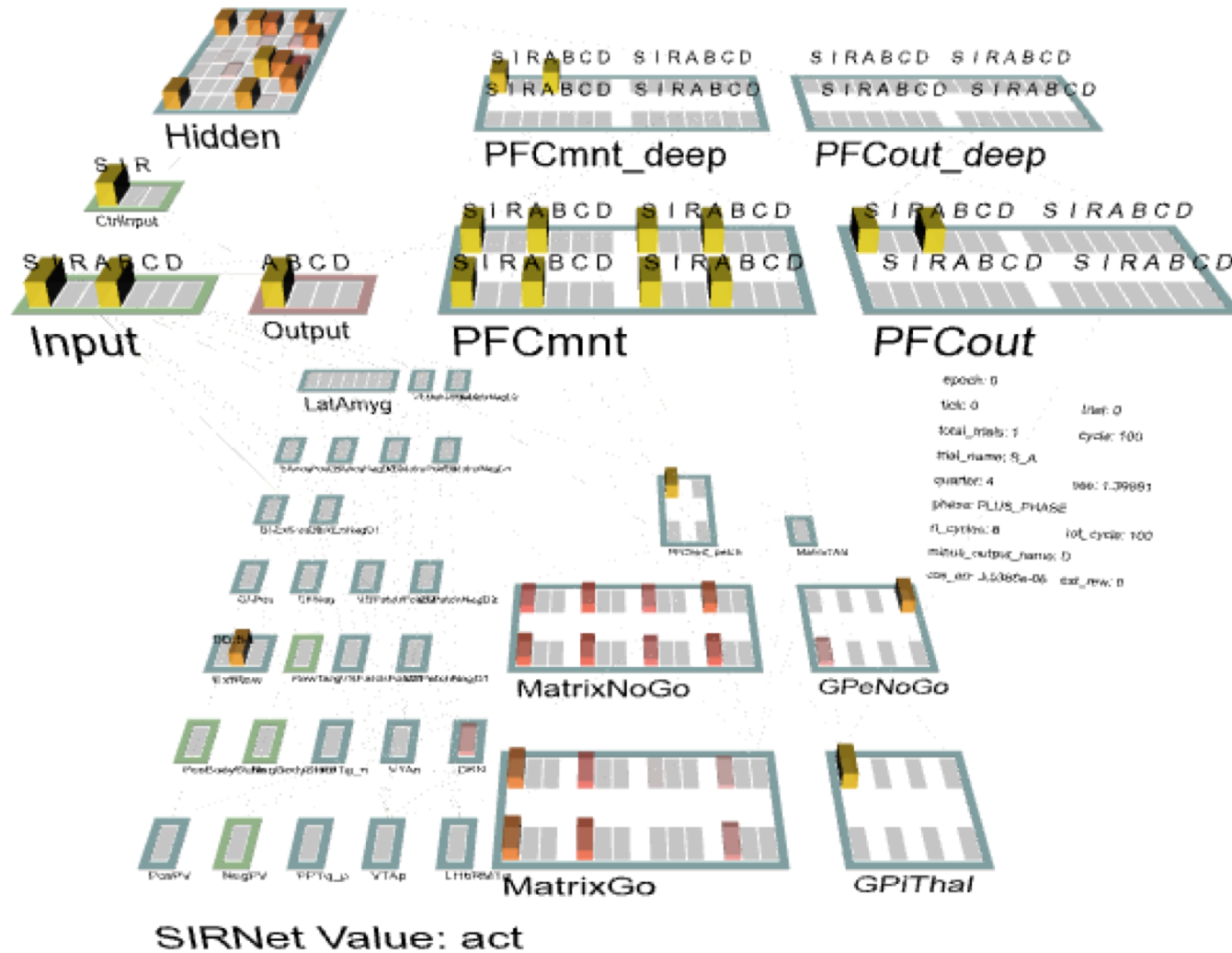

emergent Demonstration: SIR

D. Hierarchical Control

Subtasks, Goals, Cognitive Sequencing

Hierarchical Control Over Action

- Consider situations:
 - where there are multiple potential rule sets signifying which actions to select in particular sensory states, and
 - where appropriate rule set might depend on a higher level context (a “task set”)
- Hierarchical PFC-BG networks can simultaneously:
 - learn to create these PFC task-sets
 - learn which actions to select in each task-set
- Learned PFC representations are abstract and independent of contexts that cue them, facilitating transfer

Hierarchical Action Selection Across Multiple Prefrontal Basal Ganglia Loops

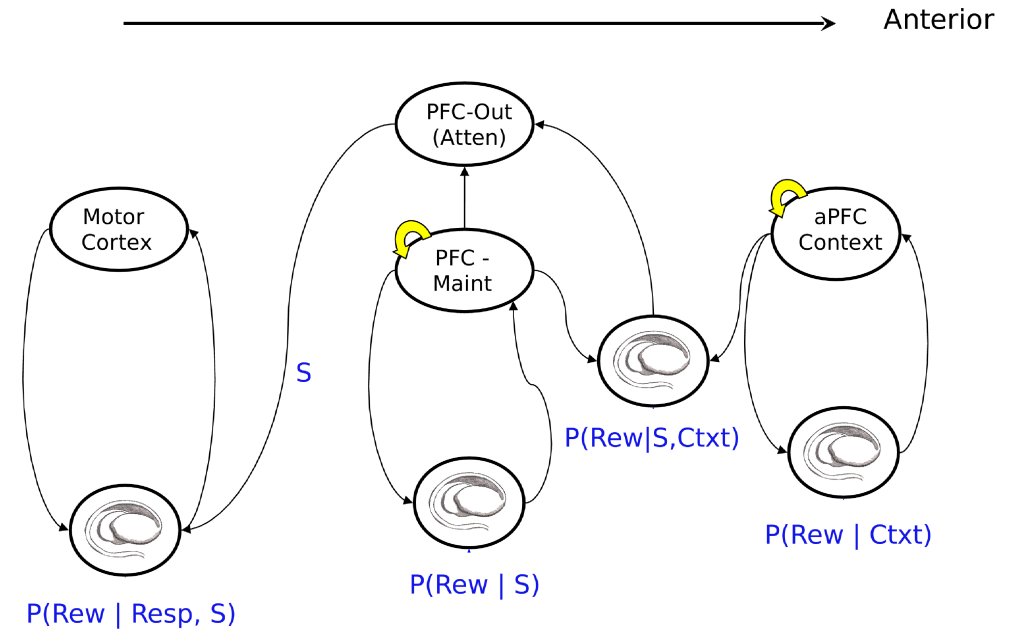

- At most anterior level, PFC represents contextual information gated by corresponding BG loop based on probability that maintaining this context is predictive of reward
- Middle loop involves input and output gating
 - input gating allows stimulus representations S to update PFC_maint layer
 - output gating gates out subset of maintained information conditional on context in anterior PFC
- Left-most motor loop learns to gate simple motor responses based on reward probabilities conditional on the stimulus; here relevant stimulus features are selected by more anterior loops

Summary of Hierarchical Control

- Higher (more anterior) levels of PFC
 - encode context/goals/plans to organize a sequence of cognitive actions
 - driven by more lower, more posterior PFC areas
 - do not specify rigid sequences of actions, but rather encode desired outcome states of a sequence of actions
 - provide context so appropriate lower-level steps will be selected
- Each step in a sequence of actions involves a consideration of the reward outcomes and effort costs of the action relative to other possible options

Affective Influences over Executive Function

- PFC and executive function (EF) integrate:
 - emotional and motivational influences
 - high-level cognitive control and planning
- Medial and ventral regions of PFC are particularly important for processing emotional and motivational factors
 - ventral medial areas including OFC: important for encoding the affective value of stimuli,
 - dorsal medial areas (esp. anterior cingulate cortex (ACC)): important for encoding affective value of motor actions and plans

Summary of Key Points

- PFC encodes information in active state through sustained firing (more flexible and rapidly updatable than synaptic changes)
- BG drives updating (dynamic gating) of PFC active memory states, enhancing flexibility
- Phasic DA signals from midbrain nuclei can train BG gating, by transferring reward associations earlier in time to onset of stimuli that predict subsequent rewards
- The PFC influences cognitive processing elsewhere via top-down excitatory biasing (e.g., Stroop model)
- Developmental changes in active memory can be explained in terms of stronger PFC active maintenance abilities (e.g., A-not-B model)
- BG dynamic gating can support flexible cognitive function by dynamically encoding some information while ignore other irrelevant information, and updating the contents of active memory (e.g., SIR and n-back models)
- Medial and ventral areas of PFC (OFC and ACC) convey affective information about stimuli and actions, respectively, and are important for properly evaluating potential actions to be taken (decision making, problem solving, etc.)

Other Executive Functions

- Highly structured cognitive activities, often involving formal symbol systems
 - mental activities like learning and/or using mathematics, formal logic, computer programming, creative and/or non-fiction writing, and structured, rational decision-making
 - require temporally-extended maintenance of task-relevant information, especially of highly abstract, symbolic nature.
 - important role of language in these and many other executive functions
- Control over encoding and retrieval of episodic information in HC
 - HC and PFC/BG systems interact significantly in many forms of EF
 - rapid learning abilities of the hippocampus complement transient, flexible active maintenance properties of PFC

Symbolic AI

- “Good Old Fashioned AI” (GOFAI) tried to start with executive function, working from top down, like a computer program
- Unfortunately, the symbolic foundation is weak and brittle
- Subsymbolic neural representation and processing provides a more robust and flexible foundation on which to build higher cognitive processes

Higher Level Cognition: What's Missing

- Planning
- Reasoning
- Decision-making
- Emotion
- Consciousness, sense of self
- Free will
- Social interaction