

Experiment 1

Bicycle Performance Characterization

ECE 482

The objectives of this experiment are:

- To define the requirements on the power electronics to be designed throughout the semester
- To characterize and find numerical parameters for the modeling of bicycle hub motors and batteries
- To become familiar with use of lab equipment

Section I of this experiment procedure deals with the characterization of the motor; Section II characterizes the battery; Section III covers simulation and hand analysis of electric bicycle mechanics.

I. Motor Characterization

In this portion of the experiment procedure, perform tests on the electric hub motor in order to determine the motor characteristics. Known characteristics of the motor are:

Motor Characteristics

- Three Phase, Wye-connected
- Permanent Magnet
- Outer-rotor
- Non-geared, direct drive
- BLDC-style windings (i.e. not sinusoidal distribution of turns)

The motor winding voltages can be modeled using the following (simplified) set of equations

$$v_a = r i_a + L \frac{di_a}{dt} + \lambda_M \omega_r \cos(\theta_r)$$

$$v_b = r i_b + L \frac{di_b}{dt} + \lambda_M \omega_r \cos\left(\theta_r - \frac{2\pi}{3}\right)$$

$$v_c = r i_c + L \frac{di_c}{dt} + \lambda_M \omega_r \cos\left(\theta_r - \frac{4\pi}{3}\right)$$

Note that ω_r is the electrical frequency, which relates to the mechanical frequency ω_m as

$$\omega_r = \frac{P}{2} \omega_m$$

where P is the number of poles. The following characteristics need to be determined, through any series of tests you find appropriate

- EMF Shape (e.g. trapezoidal, sinusoidal, other)
- Number of Poles P
- ~~Winding DC Resistance r_w~~
- ~~Winding Low-Frequency Inductance L_w~~
- Flux Linkage λ_m
- Relation between phases and hall sensors

Record all experimental results which are used to solve the parameters. Take oscilloscope screenshots as you test, which will later be used in your report to show explicitly how you arrived at the values you report. Explain, in your lab report, which parameters are solved in each test, why the test was chosen, and how the parameters were obtained from the test result

The motor may be tested while stationary or manually spun on its stand. In all tests, the hub motor windings (V_A , V_B , and V_C) are to remain open-circuited; their voltages may be measured, but no voltage or current may be applied to them.

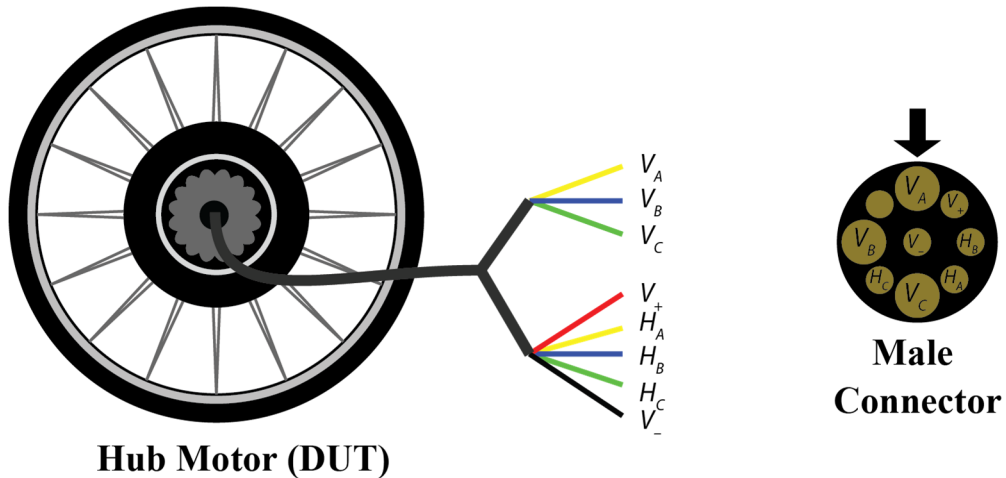

Figure 2: Motor connections diagram for experiment 1

The hub motor has a total of 8 electrical connections which may be made. The lower-gauge (larger diameter) wires comprise the three winding terminations of the motor. The higher-gauge wires connect internally to three digital-output hall sensors which may be used to determine rotor position. The hall sensors work by sensing the internal magnetic field generated by the rotating poles, with each of the three sensors outputting logic high when the magnetic field in its vicinity exceeds a predefined threshold. The three sensors are spaced 120° (electrically) apart. In this bundle of five wires, V_+ and V_- are 5V compatible supply inputs which power the hall sensors, whereas H_{A-C} are the outputs of each sensor. Note that, as shown in Fig. 3, the hall effect sensor outputs are open-collector type outputs, so an external resistor R_p is necessary to convert each signal to an observable voltage waveform. This resistor should be larger than $1k\Omega$. The series resistance R_s protects the hall sensors, and should be (roughly) 33Ω

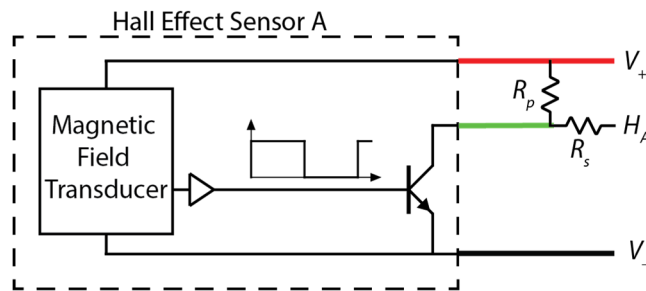

Figure 3: Motor hall sensor behavioral circuit model

Important Note: It is very easy to destroy the internal hall sensor BJT by applying a voltage at its collector. Before connecting *any* signal to the hall sensor outputs, make sure that the signal is a high impedance.

The wiring of the hub motor and end connector are shown in Fig. 2. In order to determine the relationship between the hall sensors and winding phases, produce a time-aligned plot of the voltages V_A , V_B , and V_C and sensor outputs H_{A-C} . Divide your plot into six subintervals according to the state of each Hall output.

Distinct from the sinusoidal winding current discussed in class, we will later use trapezoidal current modulation to spin the motor drive. In this type of control, during each subinterval, one phase has positive current, one phase has negative current, and one phase has zero current. For motoring operation under trapezoidal current modulation, label the phase in each subinterval which winding will conduct positive, negative, and zero current. *Hint: you want power flowing to the motor.*

II. Battery Characterization

In this portion of the experiment procedure, perform tests on Samsung INR18650-15M Lithium-ion battery cells in order to determine the characteristics. Each group has one cell available for testing, which starts near 100% state-of-charge (SOC). The battery cells have the following known parameters:

Cell Inherent Characteristics

- Capacity: 1.5 Ah
- Nominal Voltage: 3.7 V
- Maximum Discharge (pulsed): 2C
- Maximum Discharge (continuous): 2C
- Maximum Charge: 1C
- Maximum Voltage < 4.2V
- Minimum Voltage > 2.5 V

On the electric bicycle, the battery pack consists of 35 of these cells, in a 7S5P configuration (5 cells in parallel, then 7 of these 5-cell units in series).

In order to preserve the lifetime of the battery cells, facilitate safety, and comply with equipment limitations, the packs must never be run beyond these limits. To help ensure this, the batteries should be placed inside a battery holder, shown in Fig. 4, which contains integrated circuitry for over-voltage, under-voltage, and over-current protection. Nonetheless, you must take the utmost care to ensure that all testing never exceeds any of the rated specifications of the battery cell.

Before inserting the battery into the holder, make sure that the leads are not shorted together. Fig. 4 labels the positive and negative terminals of the battery. Using a multimeter, double-check to make sure that you are inserting the battery in the correct polarity.

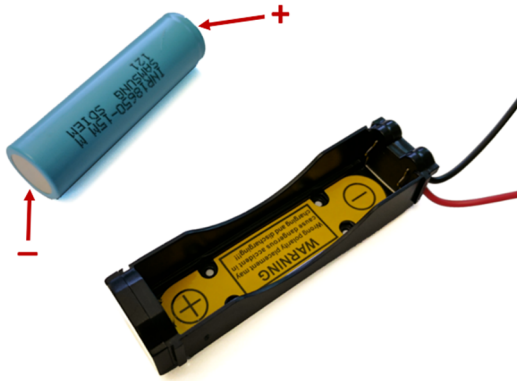

Figure 4: Battery cell and holder with integrated protection circuit

In all testing of battery cells, be first aware of the limits of testing equipment. Datasheets and user manuals for all test equipment in the lab are available from the materials section of the course website. Before running any tests, calculate the expected currents and power dissipations and make sure that they remain well within device and equipment limits. Also, note that equipment such as the electronic load has internal slew rate limitations; make sure you are not modeling the dynamics of the test equipment, rather than the battery. Keep in mind the time scales of the dynamics discussed in class.

An equivalent circuit model of a single Lithium-ion battery cell is given in Fig. 5. This is Model D, as developed in class.

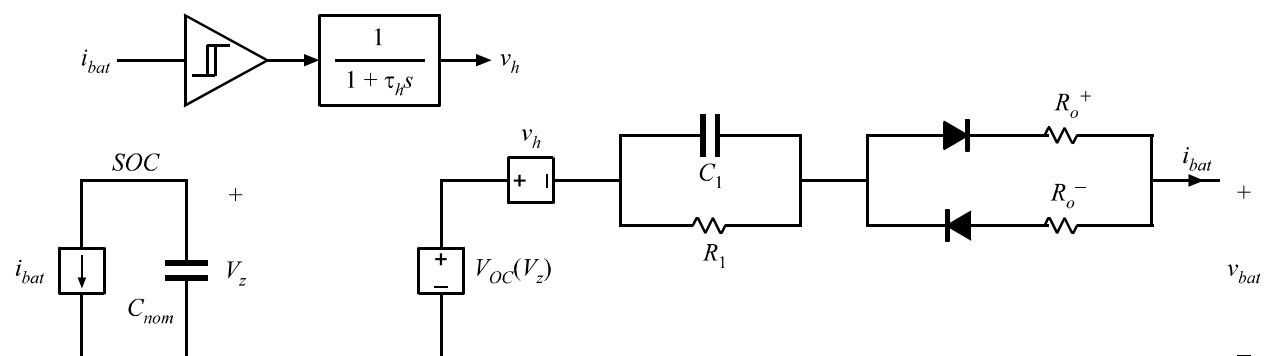

Figure 5: Equivalent circuit model of Lithium-ion battery cell

In this portion of the experiment, formulate and complete a series of tests to characterize the following cell model parameters:

- | | |
|-------------------------------|---|
| a) Voltage-vs-SOC curve | d) Hysteresis time constant τ_h |
| b) R_o^+ | e) Diffusion parameters R_l and C_l |
| c) Hysteresis Magnitude v_h | |

You may discharge the battery cells with any current waveform you wish, so long as the battery is kept within the aforementioned permissible characteristics and the waveforms are achievable with the available equipment. You should not charge the battery using any equipment other than the dedicated battery chargers in the lab. You may assume $R_o^+ = R_o^-$

Keep a record of all experimental results which are used to solve the parameters (including oscilloscope waveforms, when applicable). Report the values solved for each parameter, or explain and show why the parameter is not necessary (insignificant) in the model of this battery. Be prepared to explain, in your lab report, which parameters are solved in each test, why the test was chosen, and how the parameters were obtained from the test result. For each parameter consider the following:

- How significant is the effect of the parameter; is it necessary to include in the model?
- Is the equivalent circuit model of Fig. 5 sufficiently accurate in modeling the behavior of the actual battery cell?
- Does the circuit of Fig. 5 model all known characteristics of battery operation? What effects are neglected, if any?
- What modifications could be made to the model of Fig. 5 to more accurately model the cell behaviors?

III. Simulation Modeling and Verification

LTSpice models of a battery and an open-circuited motor are given on the experiment webpage. In each, most parameters of the elements can be adjusted by ctrl+right-clicking on the model and changing the values. A readme file is included which explains the significance of all parameters.

Separate from the tests you ran to determine the parameters of the cell, design a single, continuous test for each the battery and the motor, which can be run both experimentally and in simulation, which will show the accuracy of your model as a whole. In your report, include details of the tests you used, and show the resulting experimental and simulation waveforms, side-by-side or overlaid on one another.

IV. Vehicle Dynamics

The goal of this portion of the experiment is to determine the physical requirements of the electric bicycle drivetrain in order to meet specified performance metrics. The results of Sections I and II are necessary to complete this section, but no further experimental measurements are needed.

- Top speed of 10 mph or greater on flat road
- Ability to travel up a 3% grade ($\tan(\theta)$) at a speed of at least 5 mph

The basic free body diagram of a bicycle, including effects of drag, rolling resistance, and the tractive force F_t applied by the motor is shown in Fig. 6.

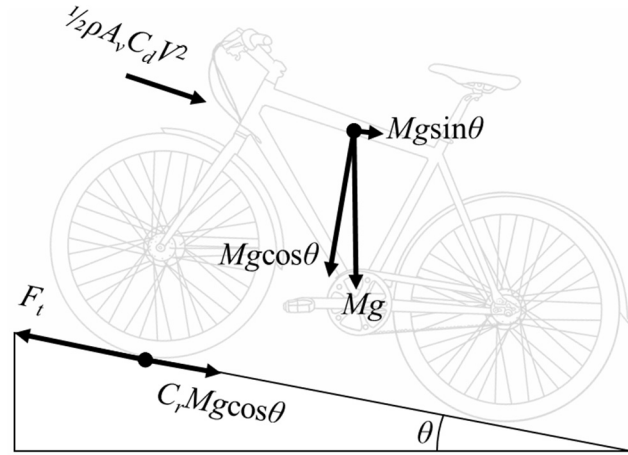

Figure 6: Bicycle free-body diagram

You may use $A_v = 0.5 \text{ m}^2$ or estimate your own frontal area on a bicycle. The bicycle weight is approximately 50 lbs. Additionally, for the rider weight, you may use your own weight or design for a 250 lb rider.

Additional characteristics of the bicycle and road conditions are:

- $C_d = 0.65$
- $C_r = 0.013$
- $\rho = 1.204 \text{ kg/m}^3$
- wheel diameter $2r_w = 700 \text{ mm}$

Using the motor parameters found in section I, the mechanical power which is transferred to the rotor is

$$P_m = P_e = i_a \lambda_M \omega_r \cos(\theta_r) + i_b \lambda_M \omega_r \cos\left(\theta_r - \frac{2\pi}{3}\right) + i_c \lambda_M \omega_r \cos\left(\theta_r - \frac{4\pi}{3}\right)$$

If the currents i_a , i_b , and i_c comprise a balanced three-phase system,

$$\begin{aligned} i_a &= I \cos(\theta_r + \varphi) \\ i_b &= I \cos\left(\theta_r + \varphi - \frac{2\pi}{3}\right) \\ i_c &= I \cos\left(\theta_r + \varphi - \frac{4\pi}{3}\right) \end{aligned}$$

and when $\varphi=0$, it can be shown that

$$\frac{P_m}{\omega_m} = \tau_m = \lambda_M \frac{P}{2} \frac{3}{2} I \quad (1)$$

Respond to each of the following in your report:

- What is the mechanical power required to meet **both** the top speed and gradeability requirements? (give one value)
- What is the peak back-emf voltage that will be generated at a speed of 10 mph?
- Comment on the time constants of the battery dynamics, and what you expect the time constants of motor (mechanical) dynamics to be during cycling.
- What is the safe voltage range (not over- or under-charged) of the complete 7S5P battery pack?

Consider and discuss, briefly, how each of these will inform the design of the power electronics in the ensuing experiments.

Finally, consider the design of the DC bus capacitance in the eventual system. Using a worst-case approximation, the DC capacitor can be designed using the equivalent circuit of Fig. 7, where $i_{md}(t)$ is the current going into the motor drive and I_{DC} is the output current from the boost converter, which is assumed to be constant over one electrical period of the motor revolution. If trapezoidal modulation is used, the motor drive current will pulse to zero for as much as 1% of the electrical period during the commutation between phases.

- If $V_{DC} = 25$ V, how large must C_{DC} be so that V_{DC} changes by less than 1 V during the time that $i_{md}(t) = 0$ in either of the performance metric cases?

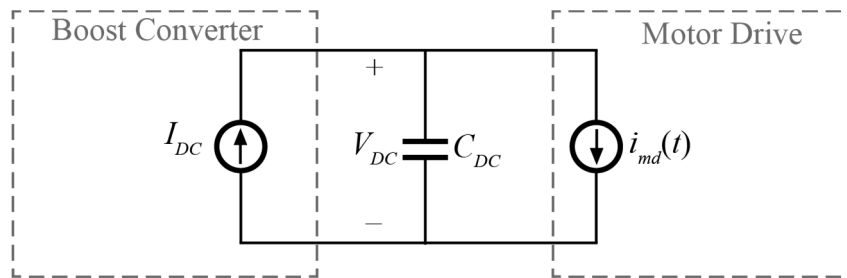

Figure 7: Equivalent circuit for DC capacitor design