

# Device Capacitances

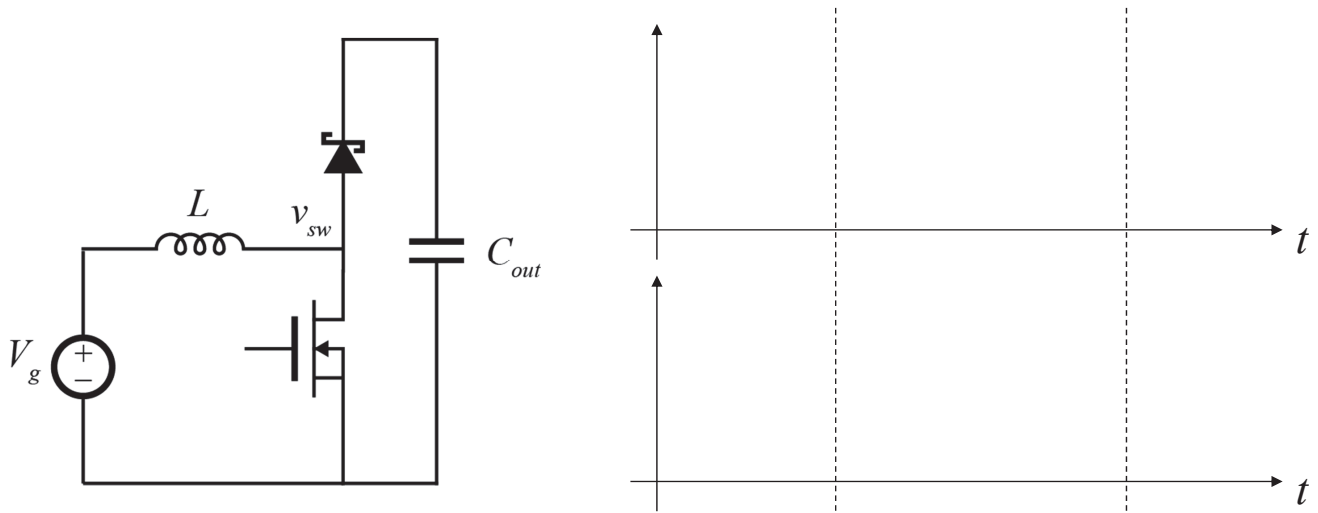

# Device Capacitances

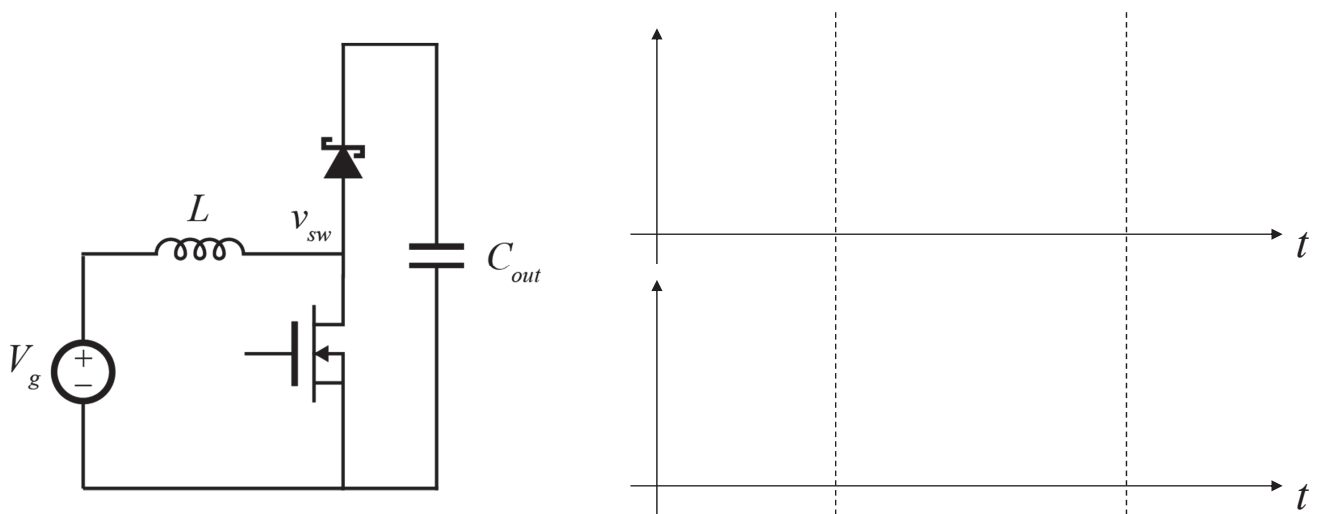

# DCM: Soft Switching

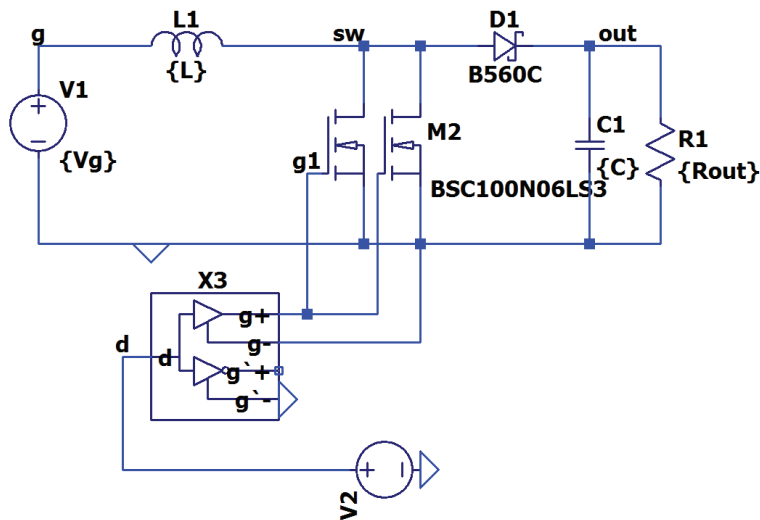

$L$	$C_{out}$	$f_s$	Diode	$\eta$ (Sim)
22uH	22uF	202k	Si (FR)	93.9%
22uH	22uF	202k	Si Schottky	95.8%
4.6uH	22uF	202k	Si Schottky	98.2%

## DCM Simulation

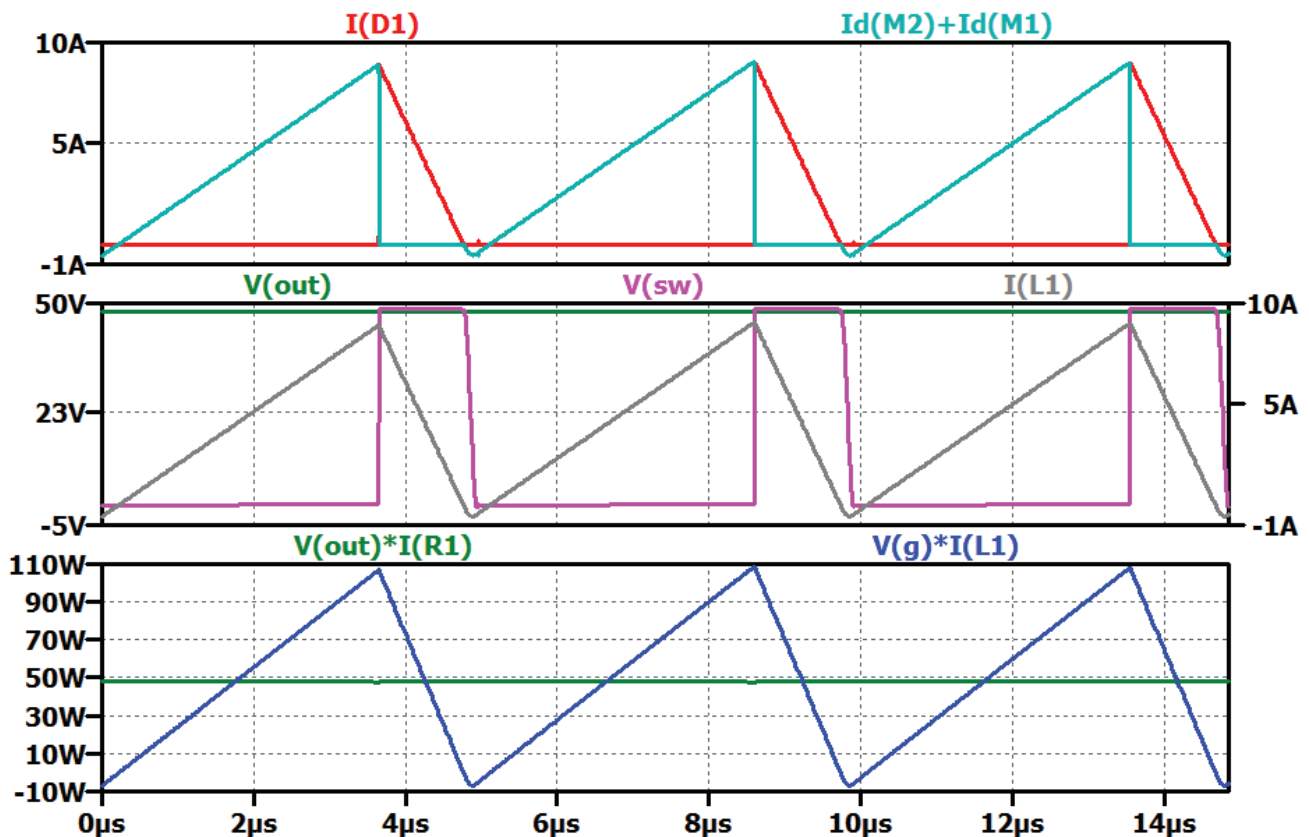

# MOSFET Turn-Off

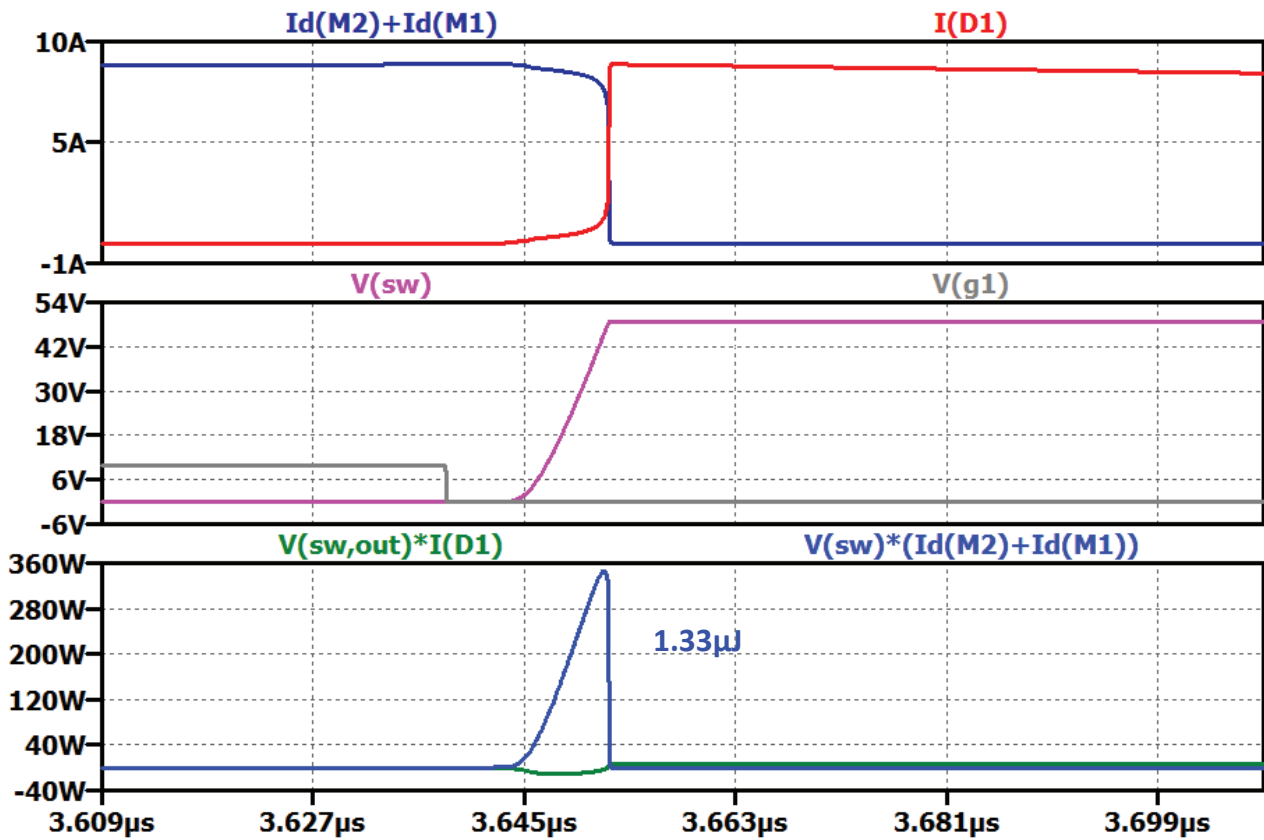

# MOSFET Turn-On

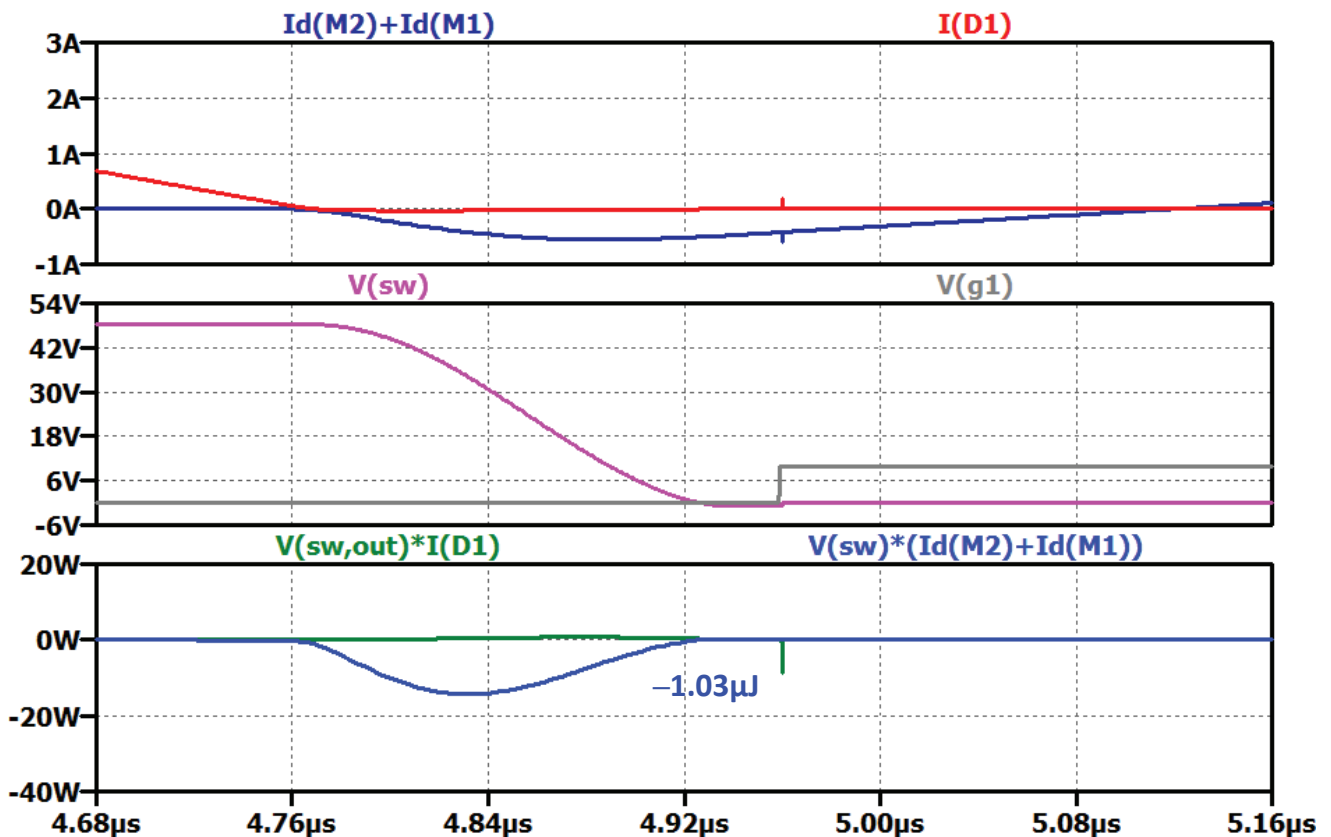

# 1 MHz Operation

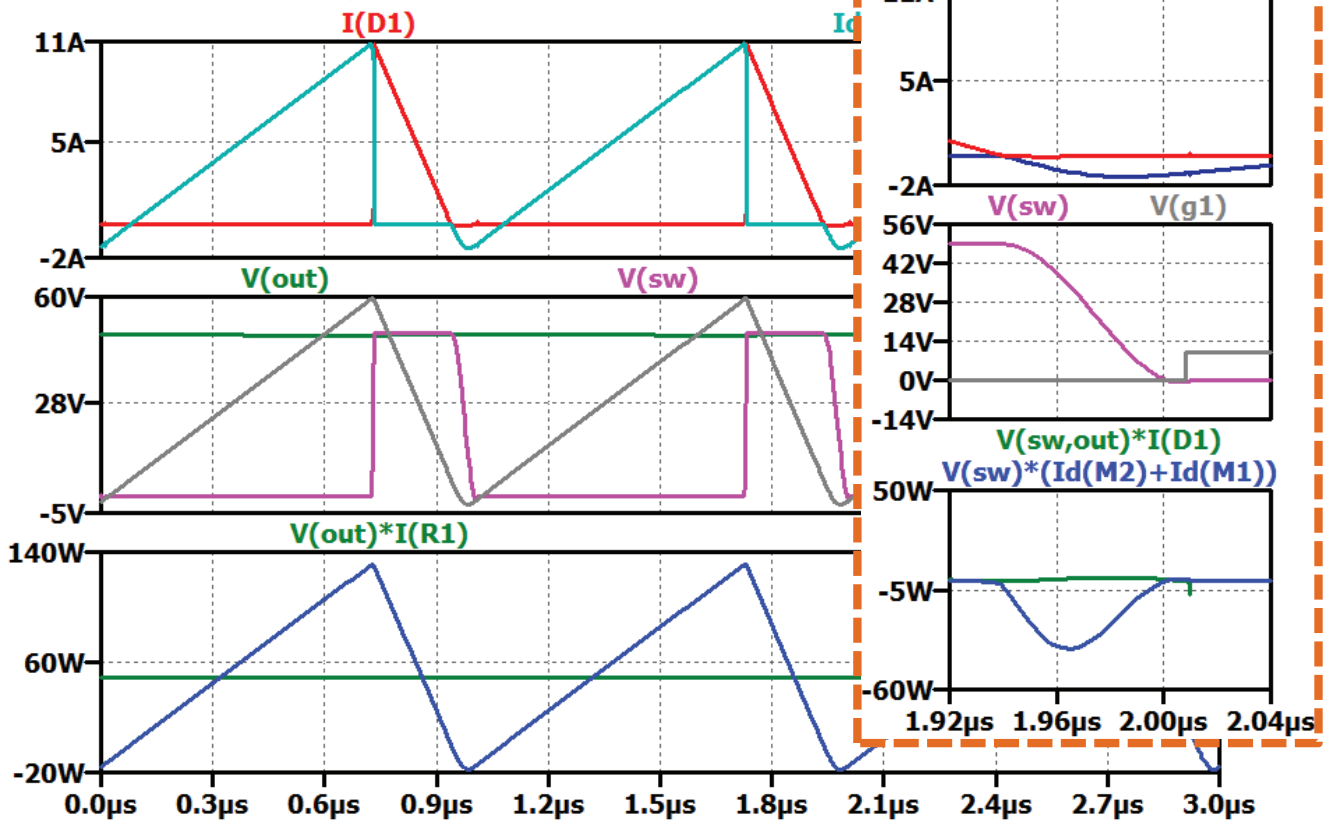

# Low Power Operation

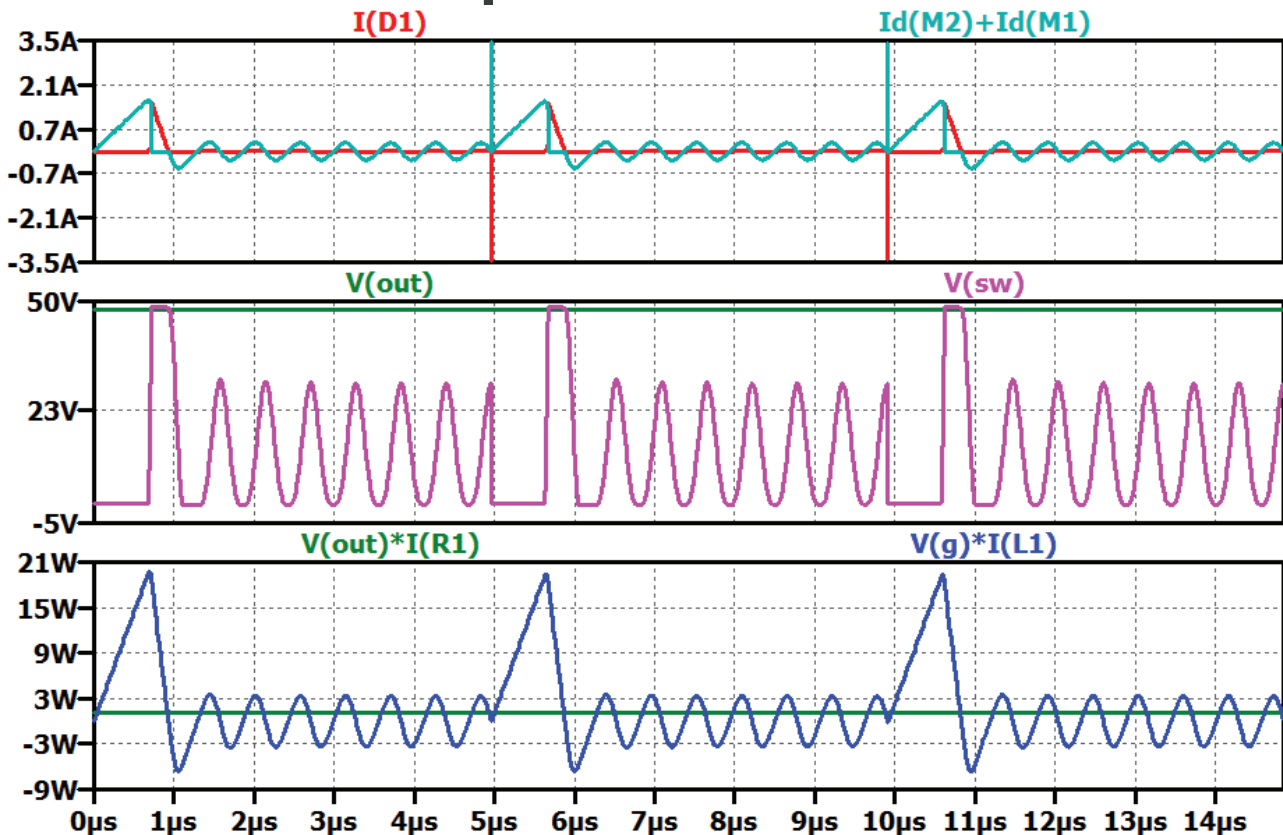

# Synchronous Operation

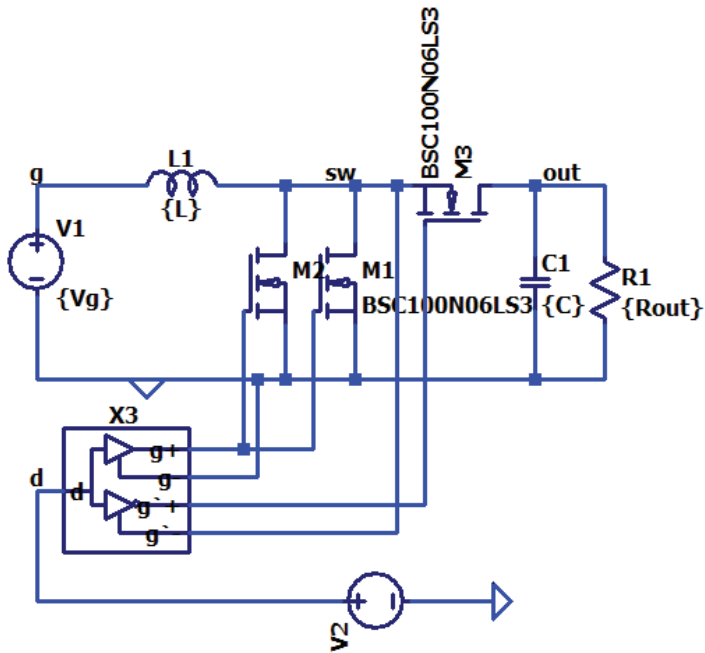

# Synchronous Simulation

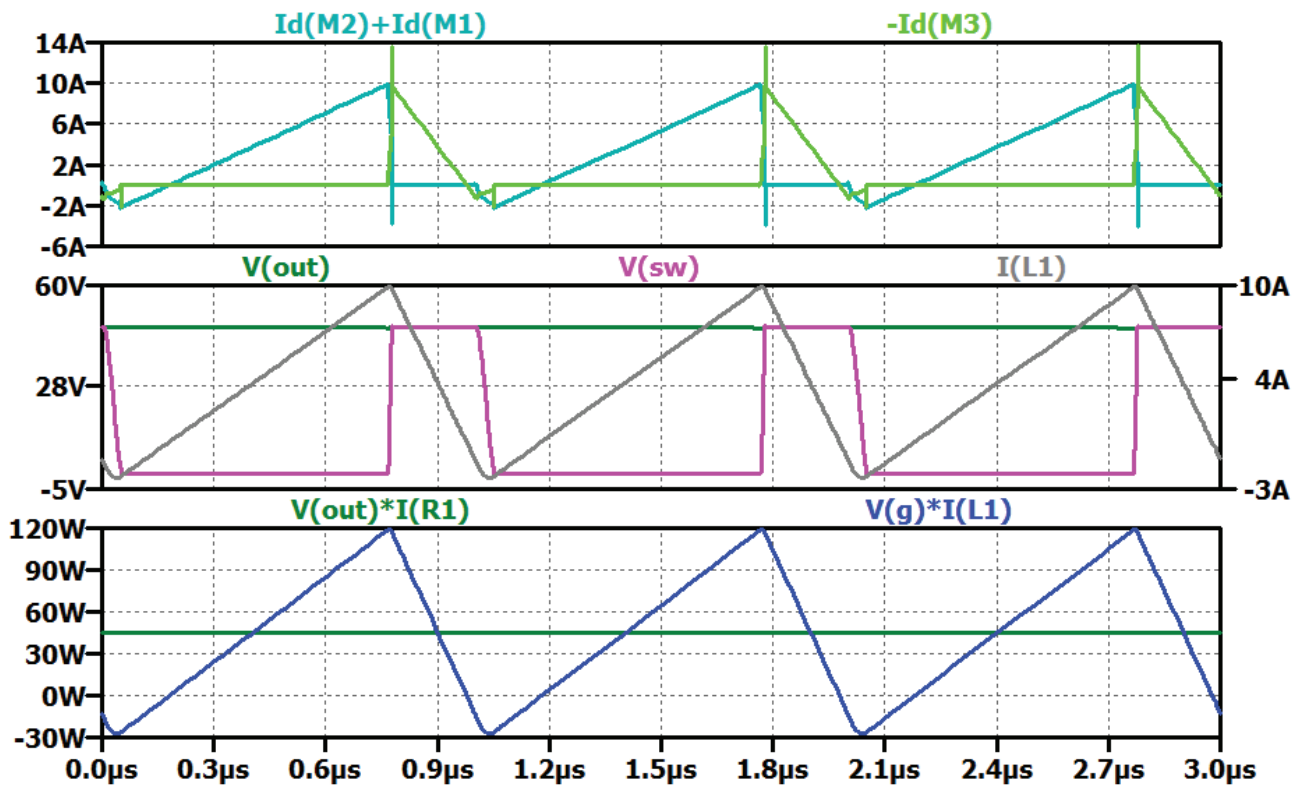

# Switching Transitions

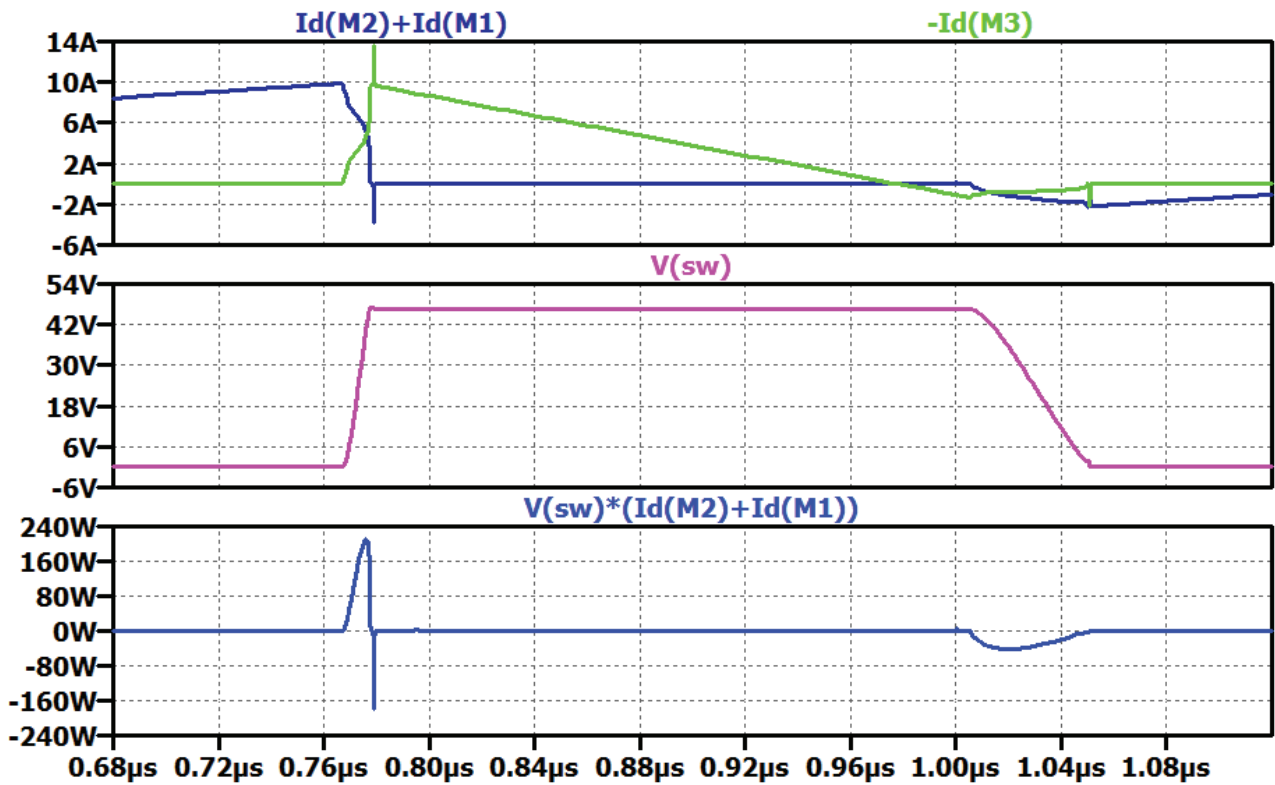

# Low Power Operation

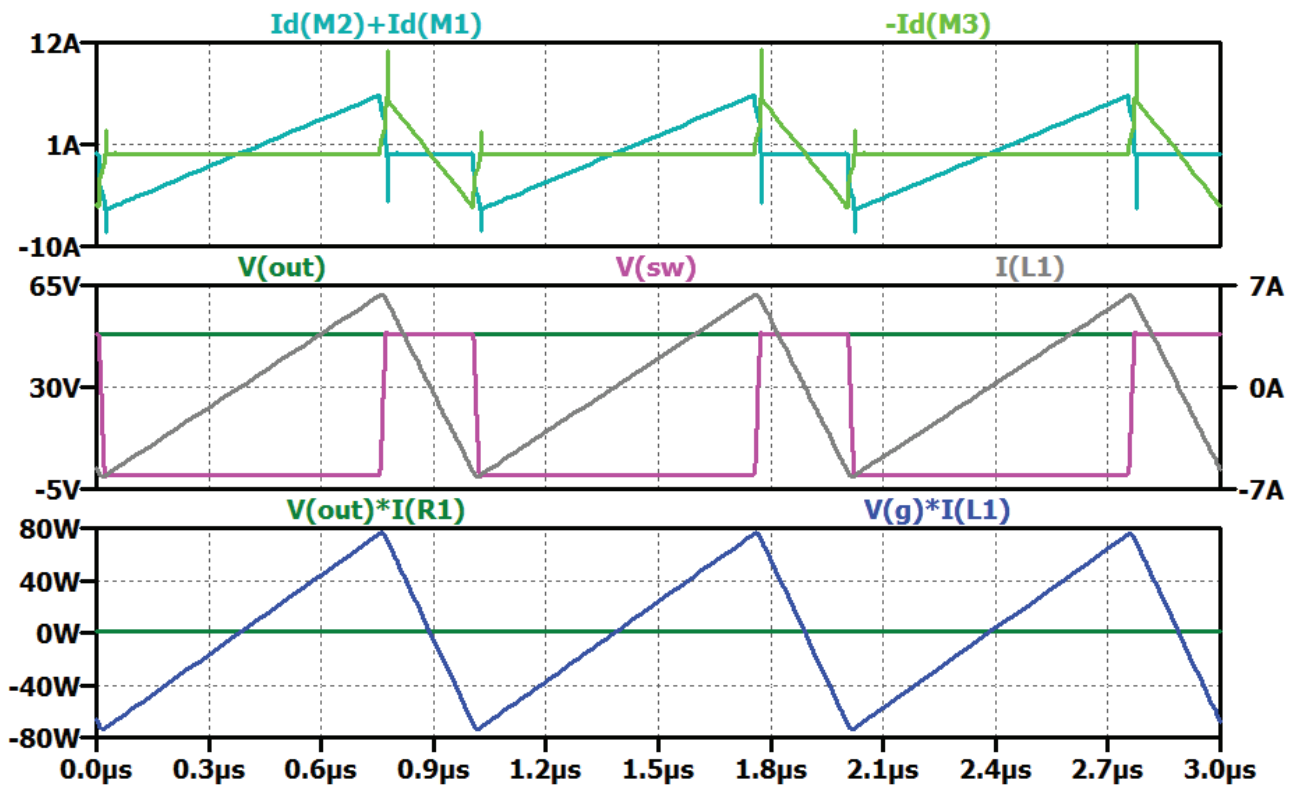

# Resonant Operation

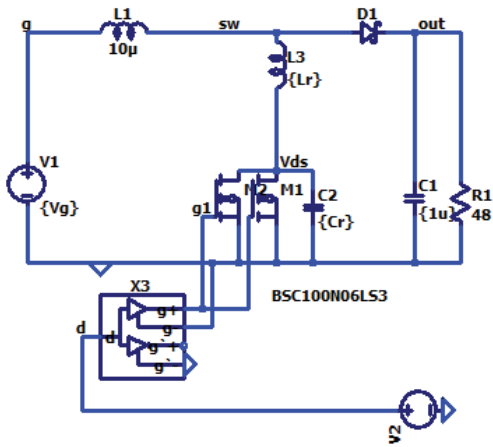

Switching	$L$	$C_{out}$	$f_s$	Diode	$\eta$ (Sim)
Hard	22uH	22uF	202k	Si (FR)	93.9%
Hard	22uH	22uF	202k	Si Schottky	95.8%
Soft	4.65uH	22uF	202k	Si Schottky	98.4%
Soft	710nH	4.4uF	1 MHz	Si Schottky	98.2%
Soft	710nH	4.4uF	1 MHz	MOSFET	99.6%
Resonant	10uH + 2.4uH	1uF + 10nF	225 kHz	Si Schottky	98.6%
Resonant	10uH + 2.4uH	1uF + 10nF	225 kHz	MOSFET	99.96%

KNOXVILLE

# Resonant Boost Converter

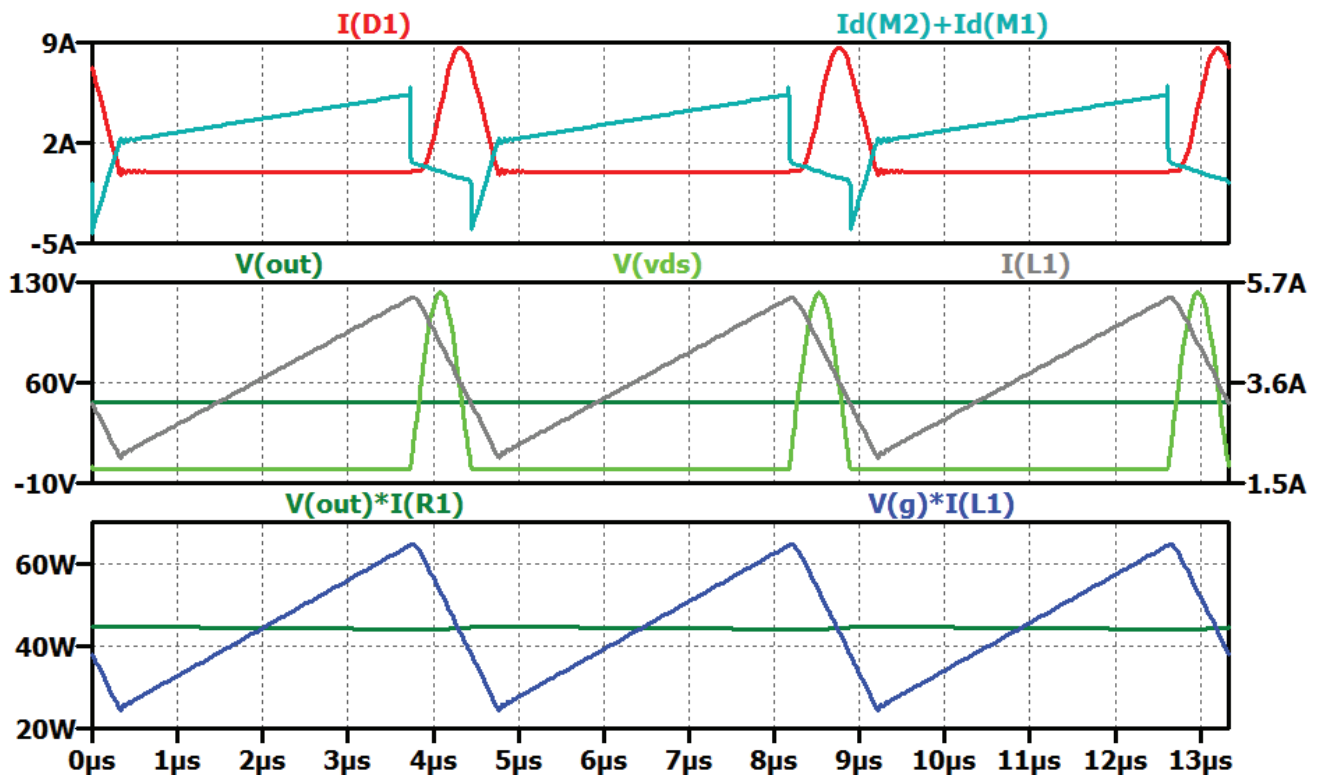

# Resonant Circuits

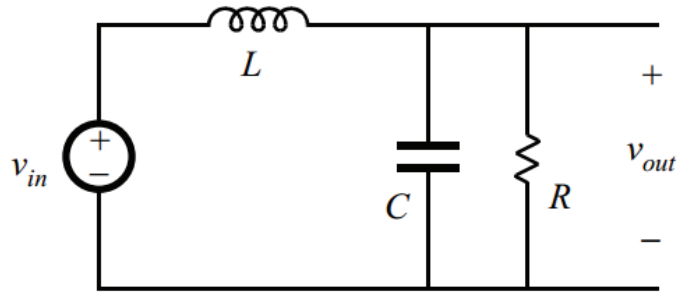

## Resonant Circuit Analysis

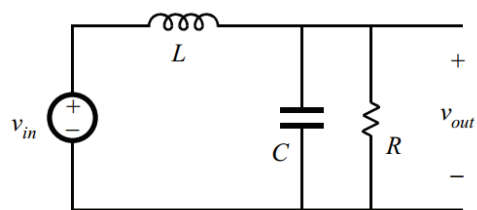



# Soft Switching

- Advantages
  - Reduced switching loss
  - Possible operation at higher switching frequency
  - Lower EMI
- Disadvantages
  - Increased current and/or voltage stresses due to circulating current
  - Higher peak and rms current values
  - Complexity of analysis and modeling