

ECE 301  
Fall Semester, 2007  
Test #2

wlg Test 2A

Name           
Print (last, first)

Work the exam on your own engineering paper. Work on one side of your paper only. Attach your work to the back of this exam sheet and staple in the top left hand corner.

- (1) You are given the RL Circuit of Figure 1. The switch has been in position 1 for a very long time. At  $t = 0$ , the switch is moved to position 2.
- (a) Use either the step-by-step method or the differential equation method to find  $i(t)$  for  $t > 0$ .
- (b) Sketch the waveform for  $i(t)$ , approximately to scale. For  $t > 0$ .

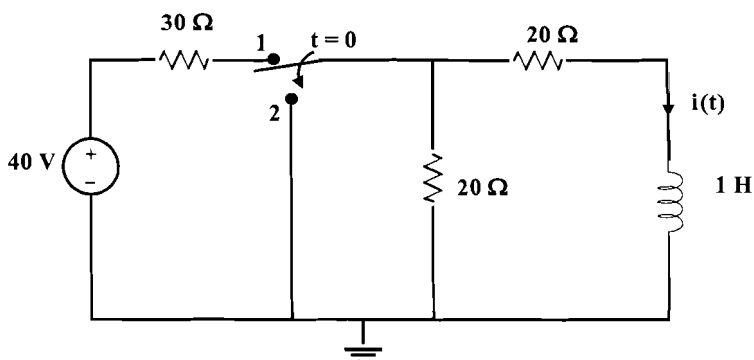

Figure 1: Circuit for problem 1.

- (2) You are given the circuit of Figure 2. The circuit is initially at rest, that is, all initial conditions for voltages and currents are zero. The indicated switch is moved from position 1 to position 2 at  $t = 0$ .
- (a) Derive the differential equation necessary for solving for  $i(t)$ ,  $t > 0$ . Use  $R$ ,  $L$ ,  $C$ , (not numerical values) in developing the differential equation.
- (b) What value of  $R$  is necessary for  $\zeta$  (damping ratio) to have a value of 0.5? Explain your work.

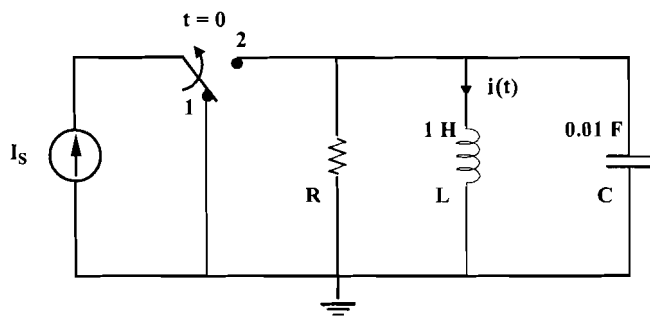

Figure 2: Circuit for problem 2.

(3) The circuit of Figure 3A is initially at rest, that is, initial conditions are zero. The switch is closed at  $t = 0$ . The resulting voltage across the capacitor is shown in Figure 3B. Using the graphical information from the voltage response and your knowledge of RC circuits, determine the following. Be sure to explain your work.

- (a) Determine the value of the resistor  $R$  shown in Figure 3A.
- (b) Determine the value of  $V_S$ , the source voltage, shown in Figure 3A.

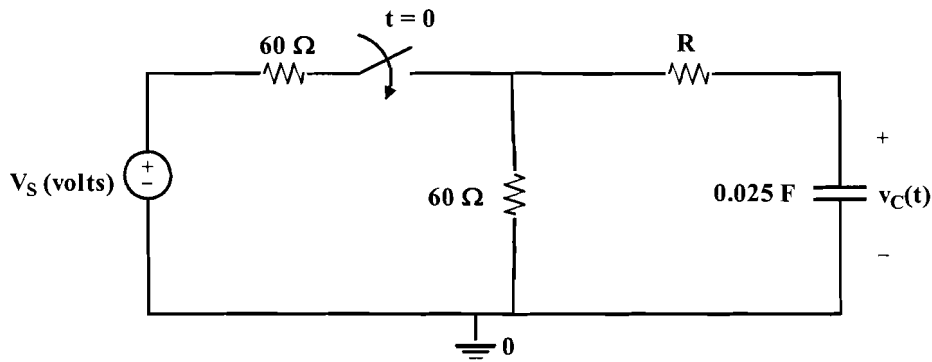

Figure 3A: Circuit for problem 3A.

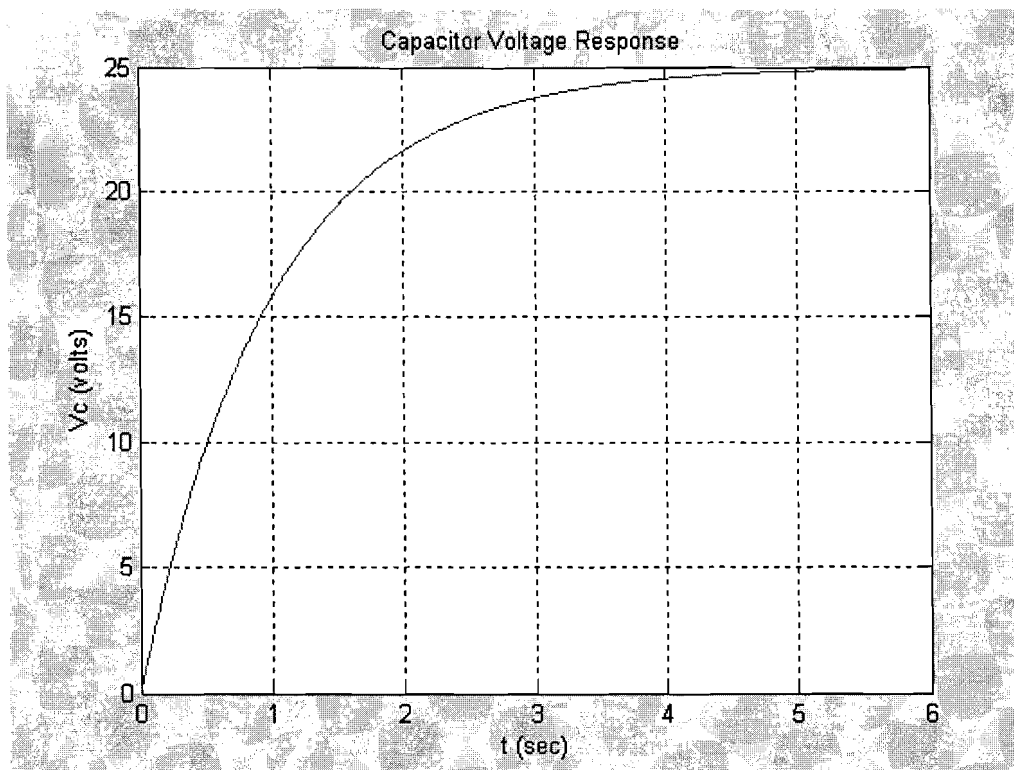

Figure 3B: Capacitor voltage response of Figure 3A.

(4) Consider the series RLC circuit shown in Figure 4. The switch has been open for a very long time and is closed at  $t=0$ .

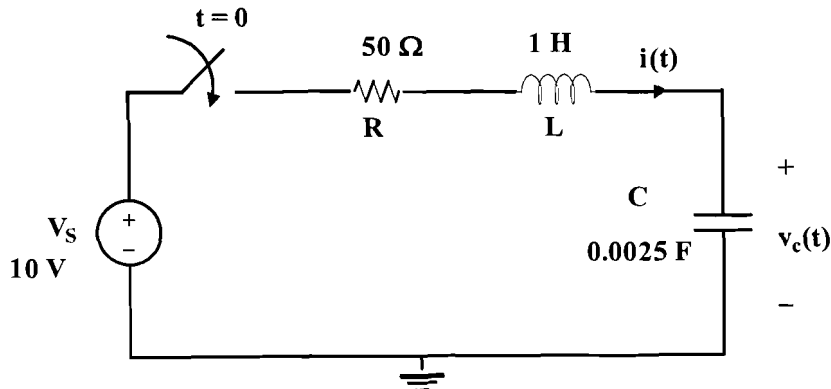

Figure 4: Circuit for problem 4.

Using the component values indicated in the diagram, the differential equation for  $i(t)$  is

$$\frac{d^2 i(t)}{dt^2} + 50 \frac{d i(t)}{dt} + 400 i(t) = 0$$

(a) Which of the following should be used to solve for  $i(t)$ ? Explain your answer.

- $i(t) = (K_1 + K_2 t) e^{-10t}$
- $i(t) = e^{-25t} [K_1 \cos 20t + K_2 \sin(20t)]$
- $i(t) = K_1 e^{-10t} + K_2 e^{-40t}$

(b) Give (determine) the following:

$$i(0^+)$$

$$\frac{di(0^+)}{dt}$$