

COSC 522 – Machine Learning

Lecture 11 – Perceptron

Hairong Qi, Gonzalez Family Professor
Electrical Engineering and Computer Science
University of Tennessee, Knoxville

<https://www.eecs.utk.edu/people/hairong-qi/>

Email: hqi@utk.edu

Course Website: <http://web.eecs.utk.edu/~hqi/cosc522/>

Roadmap

- Supervised learning
 - Classification
 - Maximum Posterior Probability (MPP): For a given x , if $P(w_1|x) > P(w_2|x)$, then x belongs to class 1, otherwise 2.
 - Parametric Learning
 - Three cases
 - Estimate Gaussian parameters using MLE
 - Nonparametric Learning
 - Parzon window (fixed window size)
 - K-Nearest Neighbor (variable window size)
 - **Neural Network**
 - Regression (linear regression with nonlinear basis functions)
 - **Neural Network**
- Unsupervised learning
 - Non-probabilistic approaches
 - kmeans, wta
 - Hierarchical approaches
 - Agglomerative clustering
 - **Neural Network**
- Supporting preprocessing techniques
 - Dimensionality Reduction
 - Supervised linear (FLD)
 - Unsupervised linear (PCA)
 - Unsupervised nonlinear (t-SNE)
- Supporting postprocessing techniques
 - Classifier Fusion
 - Performance Evaluation
- Optimization techniques
 - Gradient Descent (GD)

Questions

- The anatomy of biological neuron
- What is action potential and how does it work?
- The analogy between biological neuron and perceptron
- What is the cost function of perceptron?
- How is perceptron trained?
- What is the limitation of perceptron?
- Again, what is an epoch?

A wrong direction – the first AI winter

- One argument: Instead of understanding the human brain, we understand the computer. Therefore, NN dies out in 70s.
- 1980s, Japan started “the fifth generation computer research project”, namely, “knowledge information processing computer system”. The project aims to improve logical reasoning to reach the speed of numerical calculation. This project proved an abortion, but it brought another climax to AI research and NN research.

Biological neuron

- ◆ Dendrites: tiny fibers which carry signals to the neuron cell body
- ◆ Cell body: serves to integrate the inputs from the dendrites
- ◆ Axon: one cell has a single output which is axon. Axons may be very long (over a foot)
- ◆ Synaptic junction: an axon impinges on a dendrite which causes input/output signal transitions

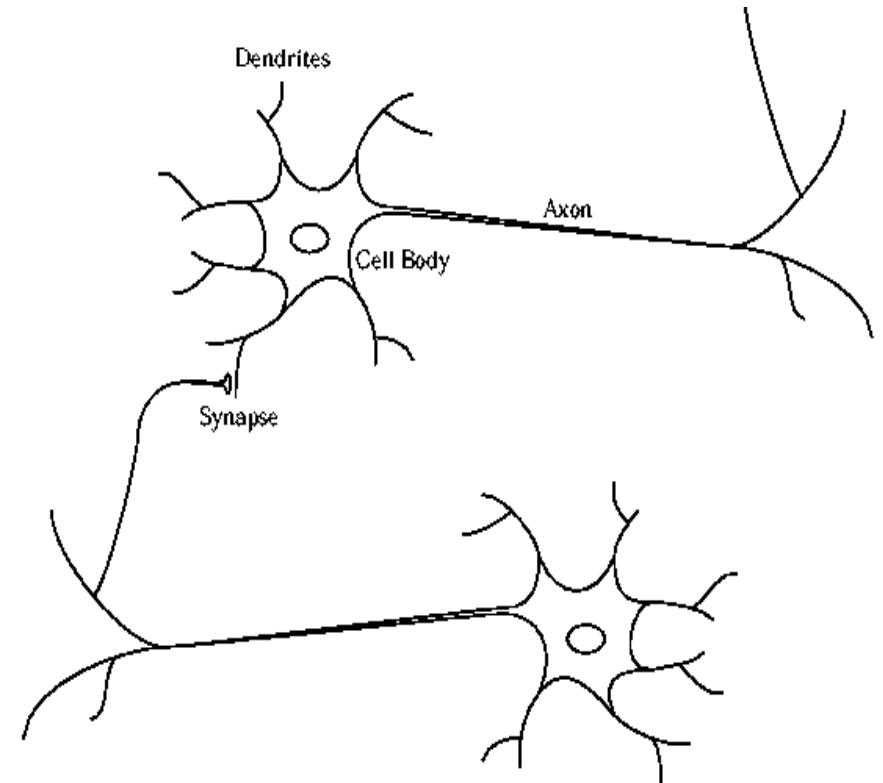

Synapse

- ◆ Communication of information between neurons is accomplished by movement of chemicals across the synapse.
- ◆ The chemicals are called neurotransmitters (generated from cell body)
- ◆ The neurotransmitters are released from one neuron (the presynaptic nerve terminal), then cross the synapse and are accepted by the next neuron at a specialized site (the postsynaptic receptor).

<http://faculty.washington.edu/chudler/chnt1.html>

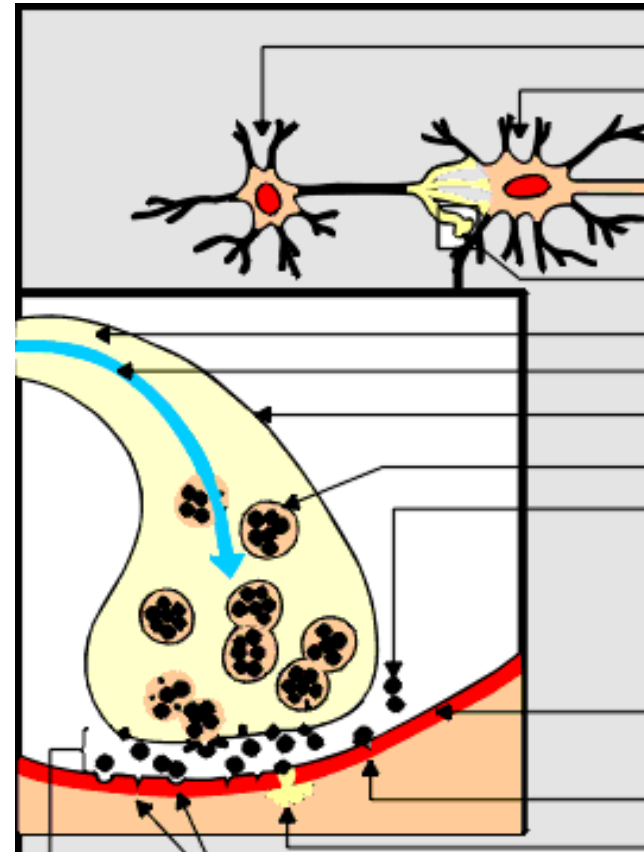

The discovery of neurotransmitters

- ◆ Otto Loewi's Experiment (1920)
- ◆ Heart 1 is connected to vagus nerve, and is put in a chamber filled with saline
- ◆ Electrical stimulation of vagus nerve causes heart 1 to slow down. Then after a delay, heart 2 slows down too.
- ◆ Acetylcholine

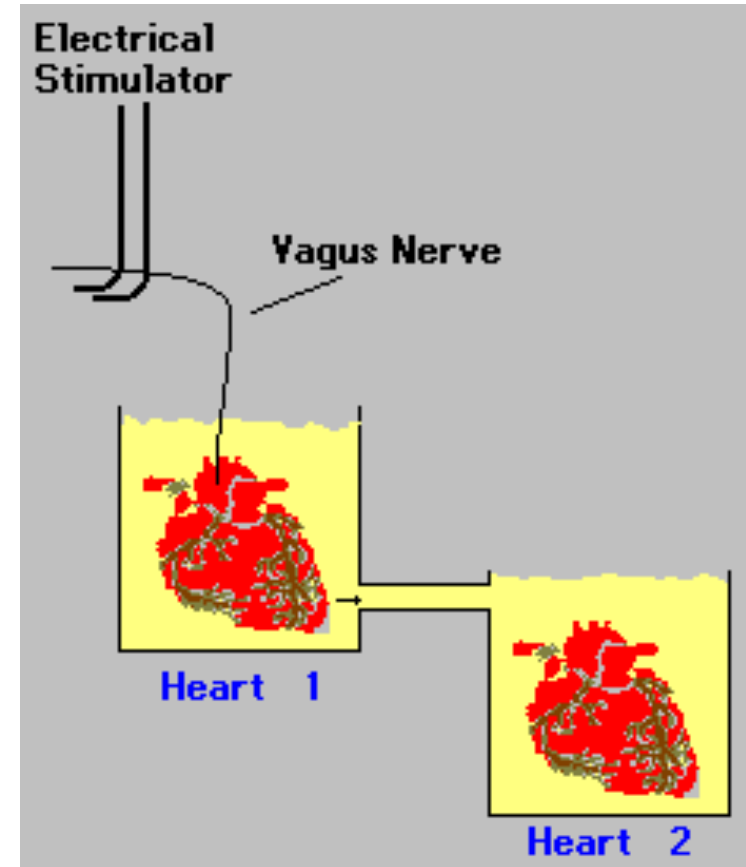

Action potential

- When a neurotransmitter binds to a receptor on the postsynaptic side of the synapse, it results in a change of the postsynaptic cell's excitability: it makes the postsynaptic cell either more or less likely to fire an action potential. If the number of excitatory postsynaptic events are large enough, they will add to cause an action potential in the postsynaptic cell and a continuation of the "message."
- Many psychoactive drugs and neurotoxins can change the properties of neurotransmitter release, neurotransmitter reuptake and the availability of receptor binding sites.

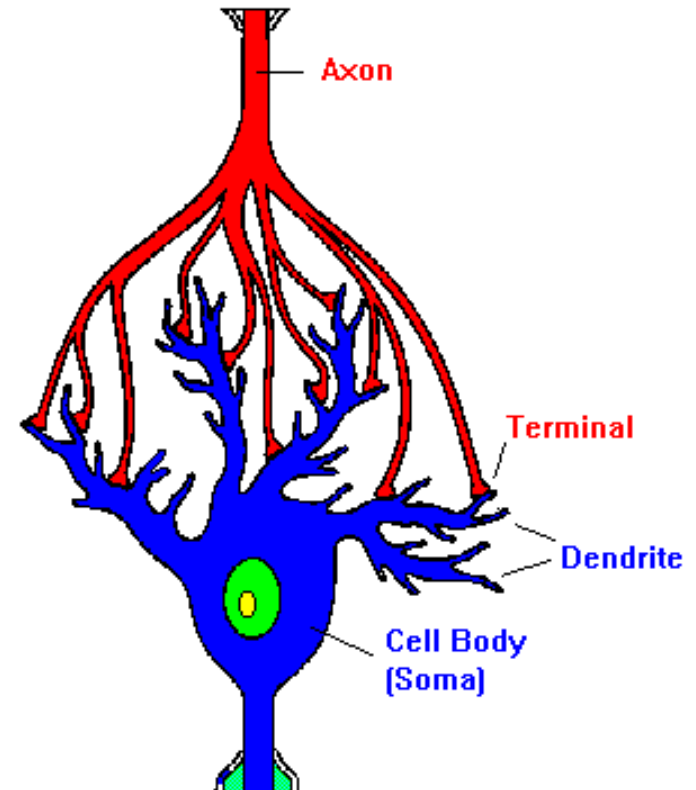

The analogy: Biological neuron and Perceptron

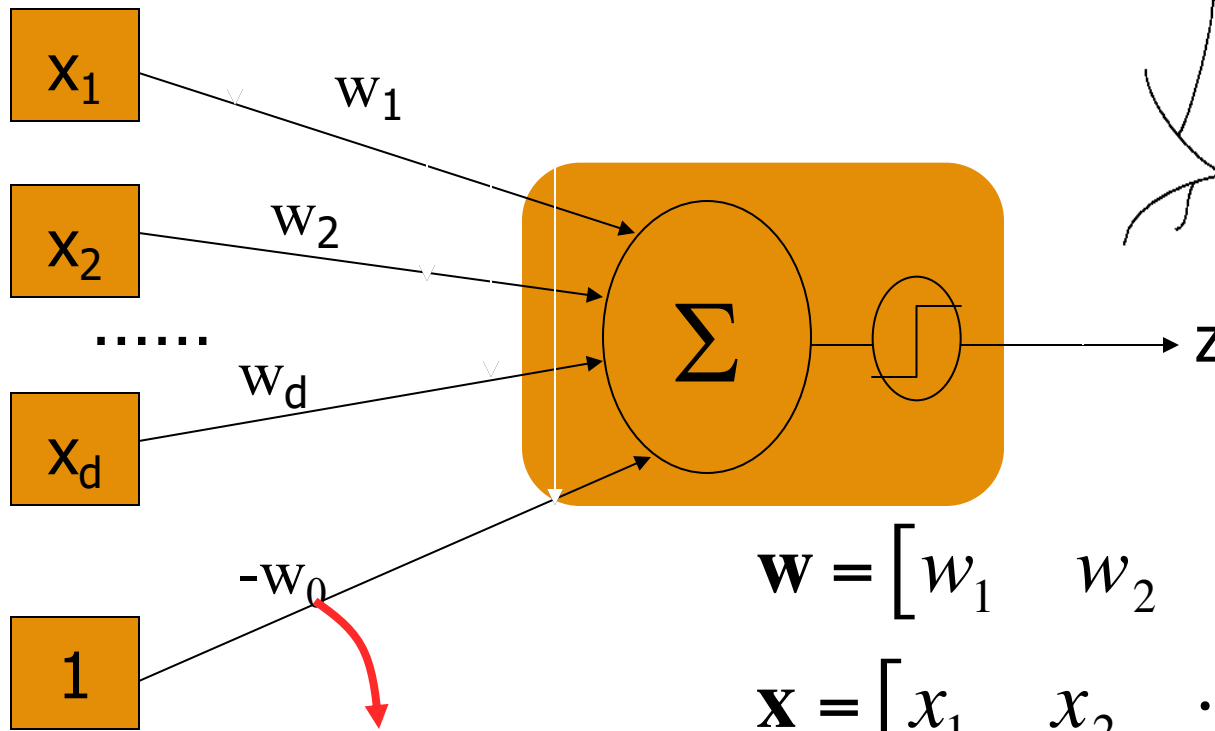
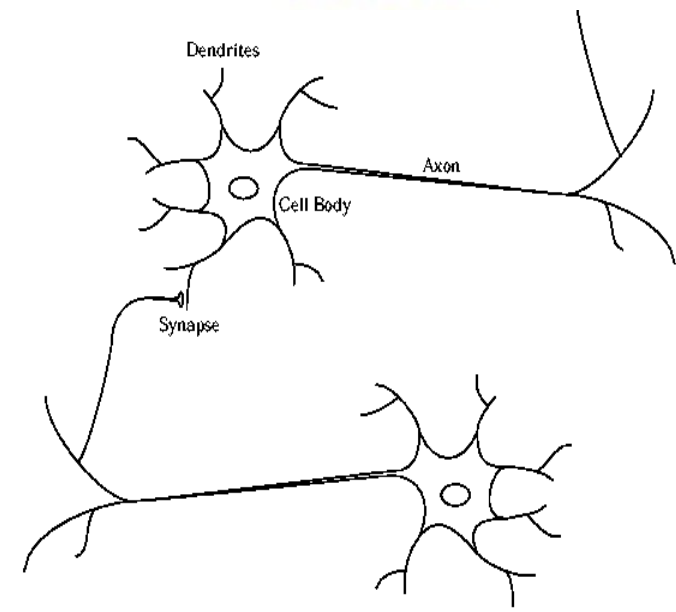

Bias or threshold

$$\mathbf{w} = [w_1 \quad w_2 \quad \cdots \quad w_d]$$

$$\mathbf{x} = [x_1 \quad x_2 \quad \cdots \quad x_d]$$

$$z = \begin{cases} 1 & \text{if } w^T x - w_0 > 0 \\ 0 & \text{otherwise} \end{cases}$$

Questions

- The anatomy of biological neuron
- What is action potential and how does it work?
- The analogy between biological neuron and perceptron
- What is the cost function of perceptron?
- How is perceptron trained?
- What is the limitation of perceptron?
- Again, what is an epoch?

Rosenblatt and Perceptron

- A program that learns “concepts” based on examples and correct answers
- It can only respond with “true” or “false”
- Single layer neural network
- By training, the weight and bias of the network will be changed to be able to classify the training set with 100% accuracy

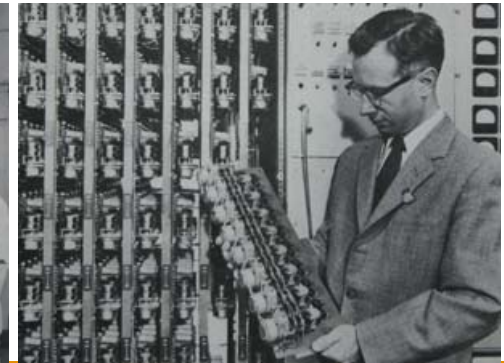
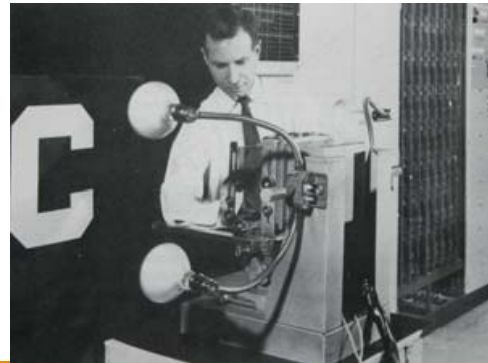

Perceptron cost function – the perceptron criterion

Initial thought:

$$J(\mathbf{w}, w_0) = \mathbf{w}^T \mathbf{x} - w_0 = \mathbf{a}^T \mathbf{y}$$

Augmentation:

$$\mathbf{a} = [w_1 \ w_2 \ \dots \ w_d \ -w_0]$$

$$\mathbf{y} = [x_1 \ x_2 \ \dots \ x_d \ 1]$$

$$\mathbf{w} = [w_1 \ w_2 \ \dots \ w_d]$$

$$\mathbf{x} = [x_1 \ x_2 \ \dots \ x_d]$$

$$z = \begin{cases} 1 & \text{if } w^T x - w_0 > 0 \\ -1 & \text{otherwise} \end{cases}$$

Perceptron criterion: $t = \{1, -1\}$

$$J_p(\mathbf{a}) = \sum_{y \in Y} (-\mathbf{a}^T \mathbf{y}) t$$

$$\nabla J_p = \sum_{y \in Y} (-\mathbf{y}) t$$

$$\mathbf{a}(k+1) = \mathbf{a}(k) + \eta(k) \sum_{y \in Y_k} \mathbf{y} t$$

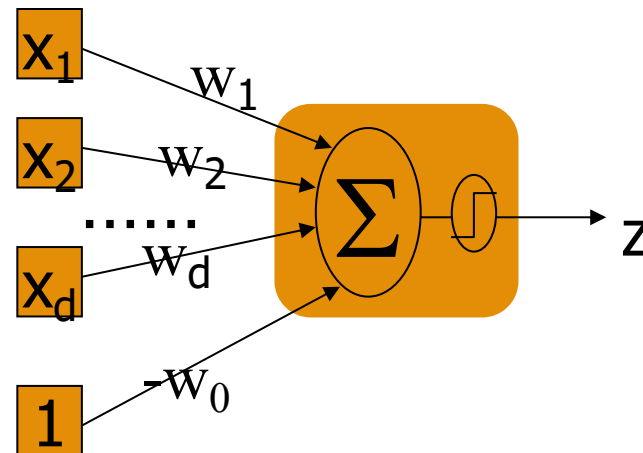

Gradient descent learning

Perceptron Learning Rule

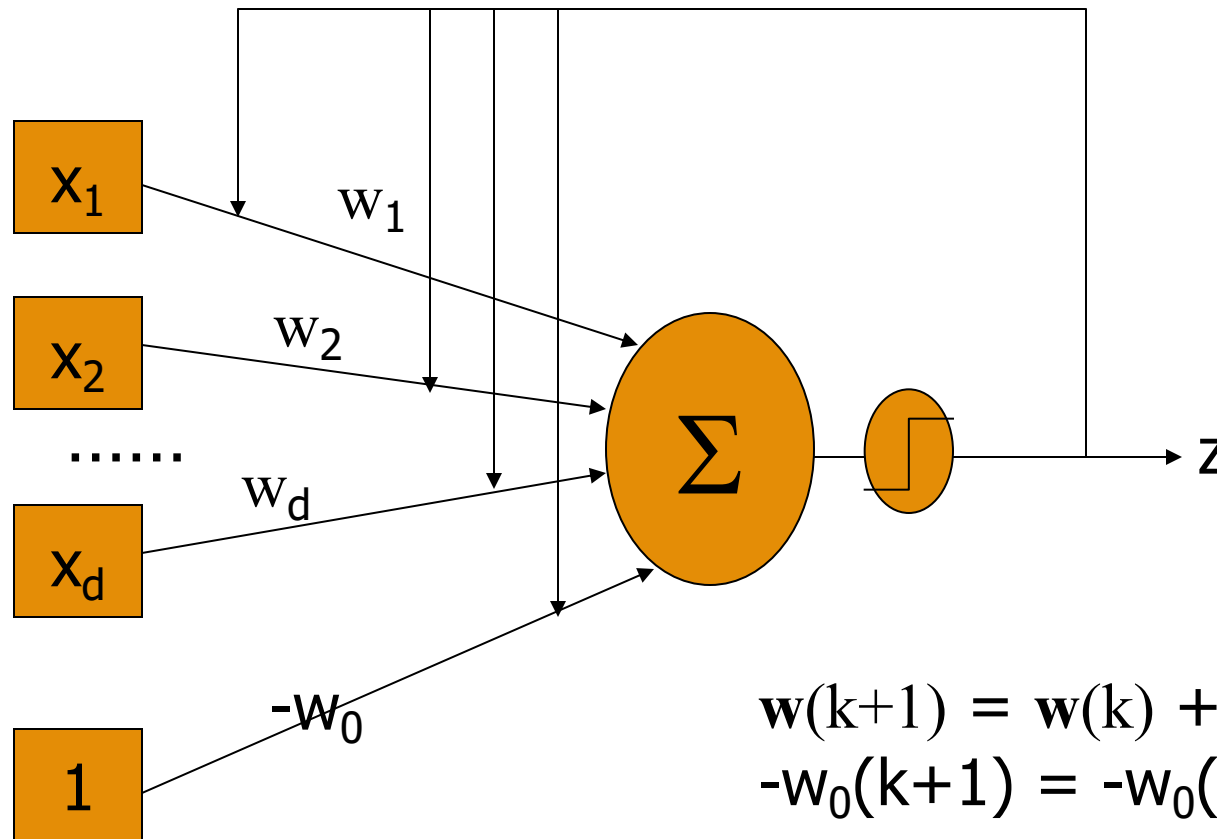

$$\mathbf{w}(k+1) = \mathbf{w}(k) + \Sigma \mathbf{x}(T-z)$$

$$-w_0(k+1) = -w_0(k) + \Sigma(T-z)$$

$$\mathbf{a}(k+1) = \mathbf{a}(k) + \eta(k) \sum_{y \in Y_k} \mathbf{y} t$$

T is the expected output
z is the real output

Training

- Step1: Samples are presented to the network
- Step2: If the output is correct, no change is made; Otherwise, the weight and biases will be updated based on perceptron learning rule. That is,
 - For Class 1, add \mathbf{x} onto the current estimate \mathbf{w}
 - For Class -1, subtract \mathbf{x} from \mathbf{w}
- Step3: An entire pass through all the training set is called an “epoch”. If no change has been made for the epoch, stop. Otherwise, go back Step1

Exercise (AND Logic)

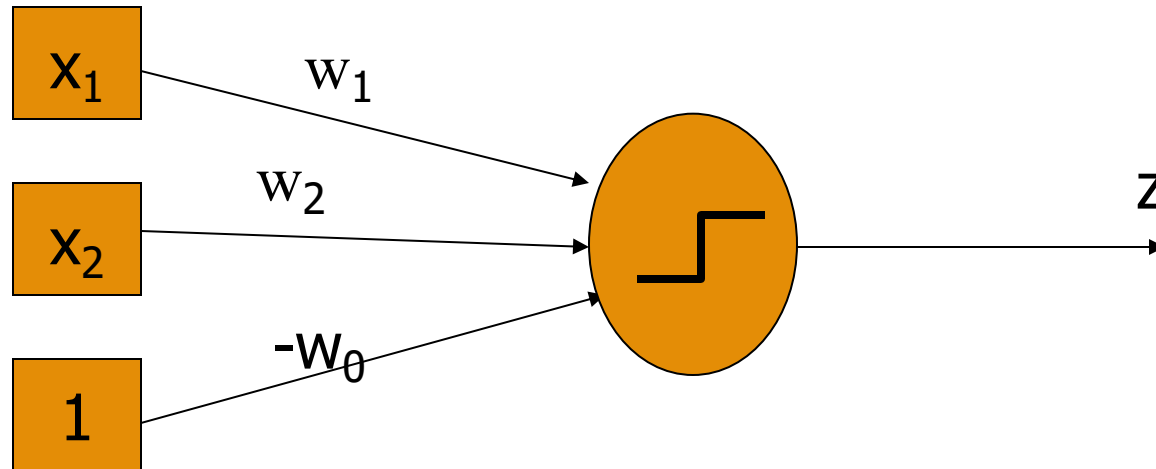

x_1	x_2	T
0	0	0
1	0	0
0	1	0
1	1	1

w_1 w_2 $-w_0$

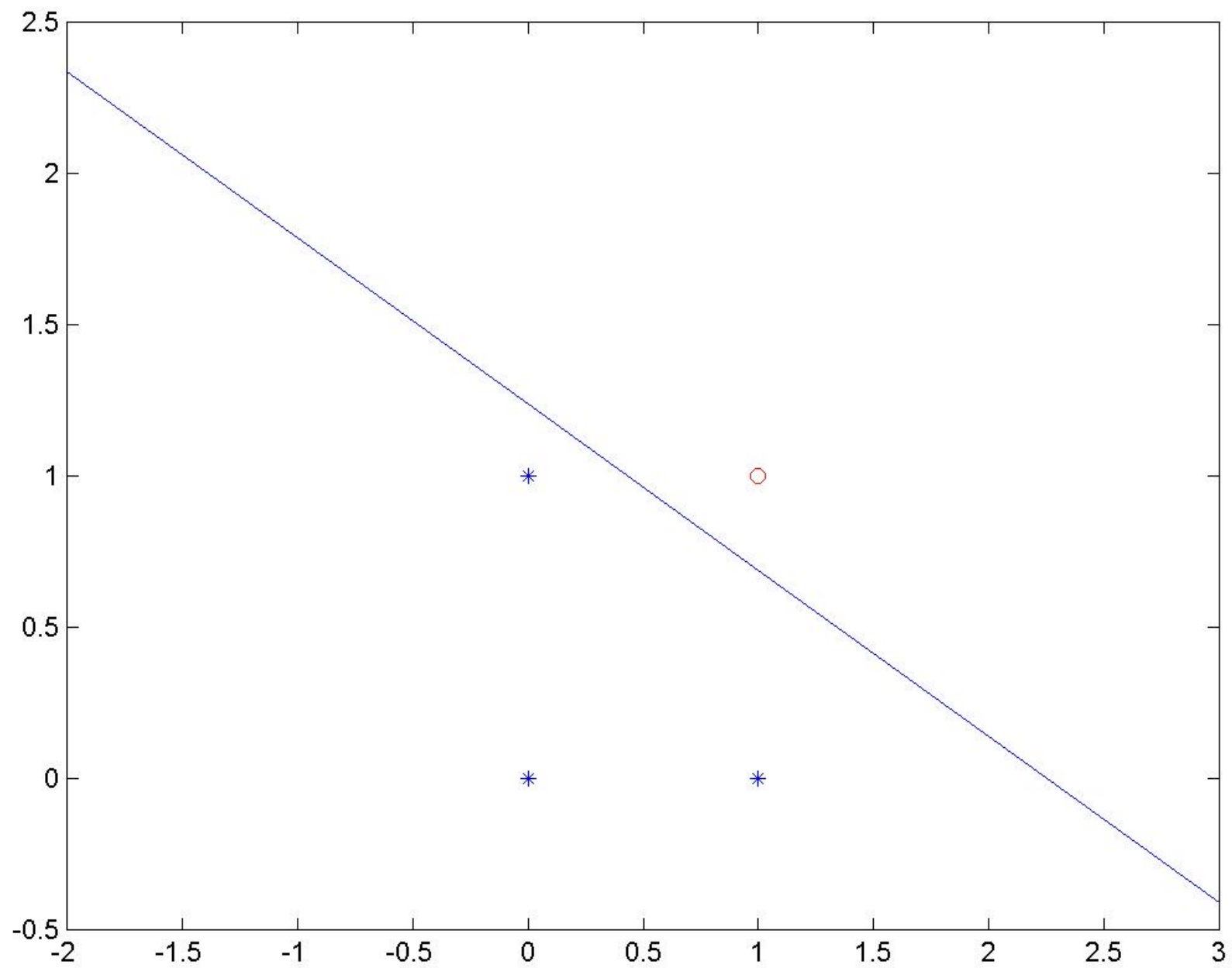

Limitations (**Limited View**)

- The output only has two values (1 or 0)
- Can only classify samples which are linearly separable (straight line or straight plane)
- Can't train network functions like XOR

Examples

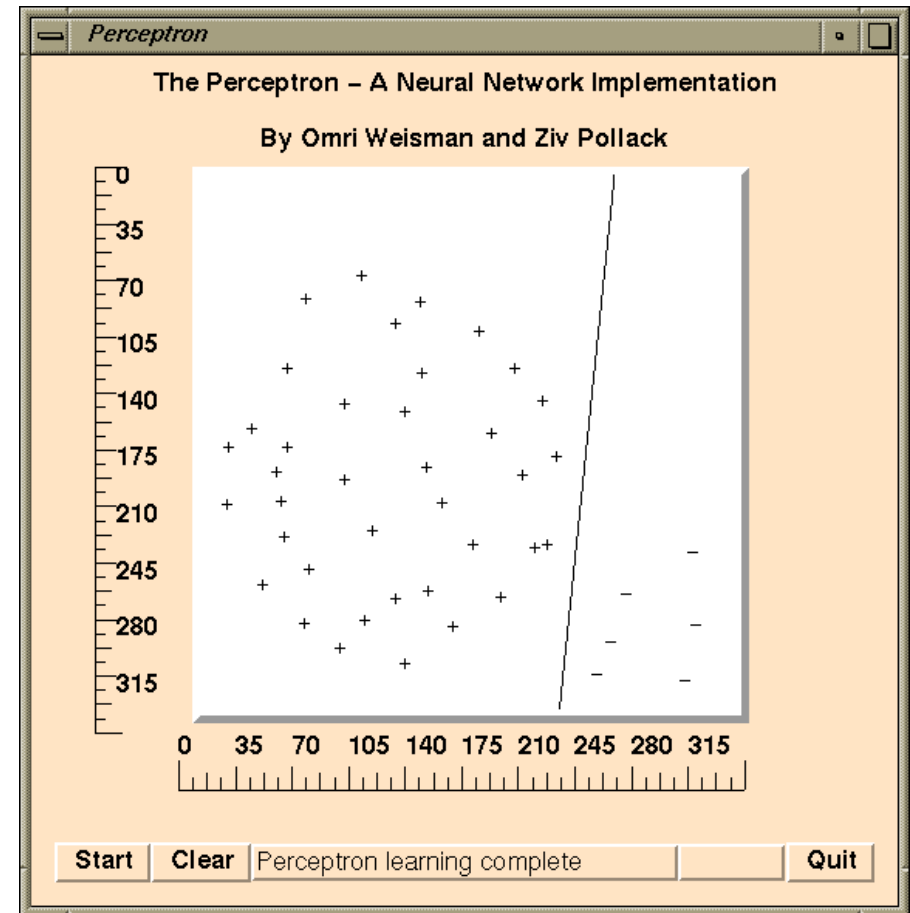
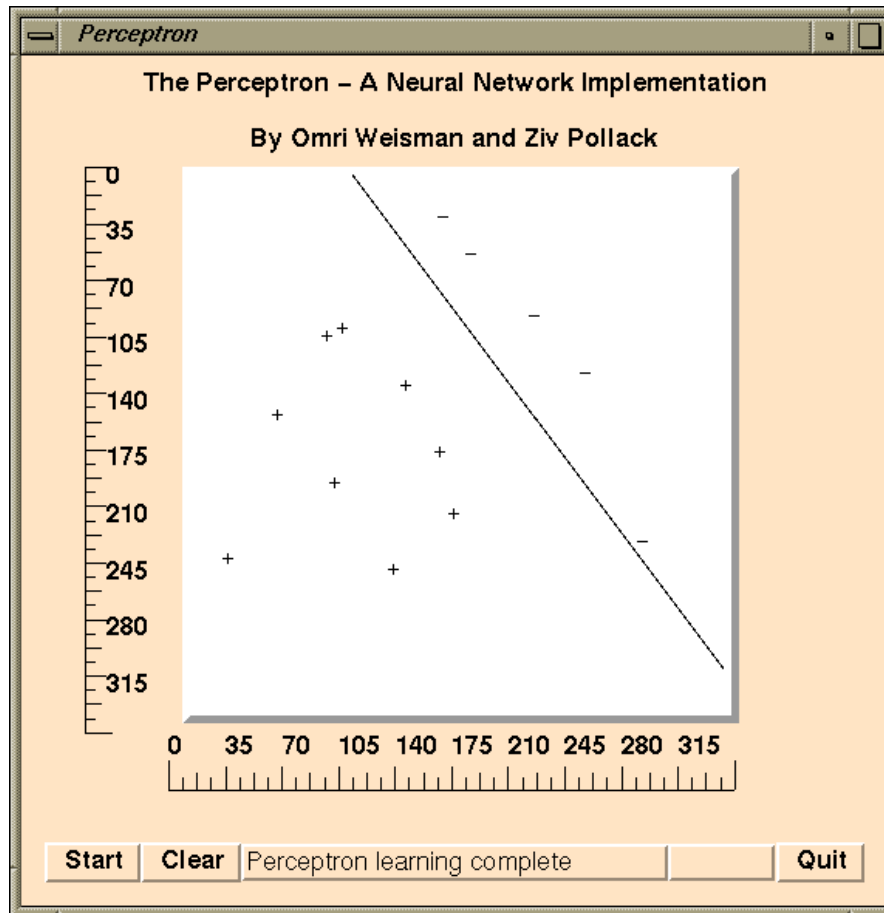

Examples

