

Elimination of Harmonics in a Multilevel Converter using the Theory of Symmetric Polynomials and Resultants

John Chiasson, Leon M. Tolbert, Keith McKenzie and Zhong Du

Abstract— A method is presented to compute the switching angles in a multilevel converter so as to produce the required fundamental voltage while at the same time not generate higher order harmonics. Previous work has shown that the transcendental equations characterizing the harmonic content can be converted to polynomial equations which are then solved using the method of resultants from elimination theory. A difficulty with this approach is that when there are several DC sources, the degrees of the polynomials are quite large making the computational burden of their resultant polynomials (as required by elimination theory) quite high. Here, it is shown that the theory of symmetric polynomials can be exploited to reduce the degree of the polynomial equations that must be solved which in turn greatly reduces the computational burden. In contrast to results reported in the literature that use iterative numerical techniques to solve these equations, the approach here produces all possible solutions.

Keywords— Multilevel Inverter, Symmetric Polynomials, Resultants.

I. INTRODUCTION

A multilevel inverter is a power electronic device built to synthesize a desired ac voltage from several levels of dc voltages. For example, the output of solar cells are dc voltages, and if this energy is to be fed into an ac power grid, a power electronic interface is required. A multilevel inverter is ideal for connecting such distributed dc energy sources (solar cells, fuel cells, the rectified output of wind turbines) to an existing ac power grid.

A key issue in the fundamental switching scheme is to determine the switching angles (times) so as to produce the fundamental voltage and not generate specific higher order harmonics. Here, techniques are given that allow one to control a multilevel inverter in such a way that it is an efficient, low total harmonic distortion (THD) inverter that can be used to interface distributed dc energy sources to a main ac grid or as an interface to a traction drive powered by fuel cells, batteries or ultracapacitors.

Previous work in [1][2][3] has shown that the transcendental equations characterizing the harmonic content can be converted into *polynomial equations* which are then solved using the method of *resultants* from *elimination theory* [4][5]. However, if there are several dc sources, the degrees of the polynomials in these equations are large. As a result, one reaches the limitations of the capability of contemporary computer algebra software tools (e.g., MATHEMATICA or MAPLE) to solve the system of polynomial equa-

tions using elimination theory (by computing the resultant polynomial of the system). A major distinction between the work in [1][2][3] and the work presented here is that here it is shown how the theory of *symmetric polynomials* [6] can be exploited to reduce the degree of the polynomial equations that must be solved so that they are within the capability of existing computer algebra software tools.

II. CASCADED H-BRIDGES

A cascade multilevel inverter consists of a series of H-bridge (single-phase full-bridge) inverter units. The general function of this multilevel inverter is to synthesize a desired voltage from several separate dc sources (SDCSs), which may be obtained from solar cells, fuel cells, batteries, ultracapacitors, etc. Figure 1 shows a single-phase structure of a cascade inverter with SDCSs [7]. Each SDCS is connected to a single-phase full-bridge inverter. Each inverter level can generate three different voltage outputs, $+V_{dc}$, 0 and $-V_{dc}$ by connecting the dc source to the ac output side by different combinations of the four switches, S_1 , S_2 , S_3 and S_4 .

The ac output of each level's full-bridge inverter is connected in series such that the synthesized voltage waveform is the sum of all of the individual inverter outputs. The number of output phase voltage levels in a cascade multilevel inverter is then $2s + 1$, where s is the number of dc sources. An example phase voltage waveform for an 11-level cascaded multilevel inverter with five SDCSs ($s = 5$) and five full bridges is shown in Figure 2. The output phase voltage is given by $v_{an} = v_{a1} + v_{a2} + v_{a3} + v_{a4} + v_{a5}$.

With enough levels and an *appropriate* switching algorithm, the multilevel inverter results in an output voltage that is almost sinusoidal. For the 11-level example shown in Figure 2, the waveform has less than 5% THD with each of the H-bridges' active devices switching only at the fundamental frequency.

III. MATHEMATICAL MODEL OF SWITCHING FOR THE MULTILEVEL CONVERTER

Following the development in [3] (see also [8][9][10]), the Fourier series expansion of the (staircase) output voltage waveform of the multilevel inverter as shown in Figure 2 is

$$V(\omega t) = \sum_{n=1,3,5,\dots}^{\infty} \frac{4V_{dc}}{n\pi} \times \left(\cos(n\theta_1) + \cos(n\theta_2) + \dots + \cos(n\theta_s) \right) \sin(n\omega t) \quad (1)$$

J. Chiasson, L. M. Tolbert, K. McKenzie and Z. Du are with the ECE Department, University of Tennessee, Knoxville, TN 37996. chiasson@utk.edu, tolbert@utk.edu, kmc18@utk.edu, zdu1@utk.edu

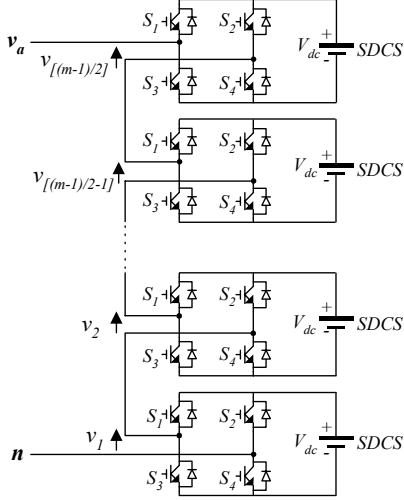

Fig. 1. Single-phase structure of a multilevel cascaded H-bridges inverter.

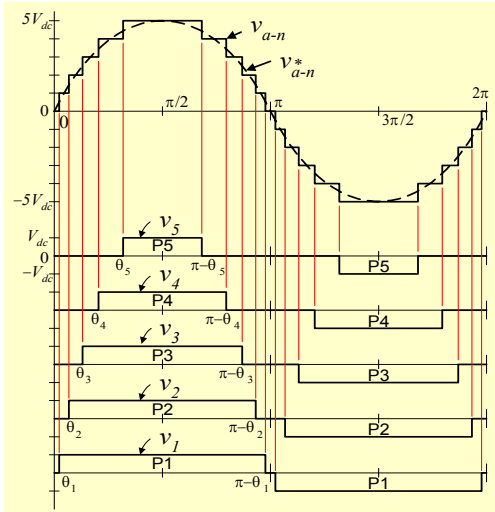

Fig. 2. Output waveform of an 11-level cascade multilevel inverter.

where s is the number of dc sources. Ideally, given a desired fundamental voltage V_1 , one wants to determine the switching angles $\theta_1, \dots, \theta_s$ so that (1) becomes $V(\omega t) = V_1 \sin(\omega t)$. In practice, one is left with trying to do this approximately. The goal here is to choose the switching angles $0 \leq \theta_1 < \theta_2 < \dots < \theta_s \leq \pi/2$ so as to make the first harmonic equal to the desired fundamental voltage V_1 and specific higher harmonics of $V(\omega t)$ equal to zero. As the application of interest here is a three-phase system, the triplen harmonics in each phase need not be canceled as they automatically cancel in the line-to-line voltages. Specifically, in case of $s = 5$ dc sources, the desire is to cancel the 5th, 7th, 11th, 13th order harmonics as they dominate the total harmonic distortion. The mathematical statement of

these conditions is then

$$\begin{aligned} \frac{4V_{dc}}{\pi} (\cos(\theta_1) + \cos(\theta_2) + \dots + \cos(\theta_5)) &= V_1 \\ \cos(5\theta_1) + \cos(5\theta_2) + \dots + \cos(5\theta_5) &= 0 \\ \cos(7\theta_1) + \cos(7\theta_2) + \dots + \cos(7\theta_5) &= 0 \quad (2) \\ \cos(11\theta_1) + \cos(11\theta_2) + \dots + \cos(11\theta_5) &= 0 \\ \cos(13\theta_1) + \cos(13\theta_2) + \dots + \cos(13\theta_5) &= 0. \end{aligned}$$

This is a system of five transcendental equations in the five unknowns $\theta_1, \theta_2, \theta_3, \theta_4, \theta_5$. The question here is ‘‘When does the set of equations (2) have a solution?’’. The correct solution to the conditions (2) would mean that the output voltage of the 11-level inverter would not contain the 5th, 7th, 11th and 13th order harmonic components. One approach to solving this set of nonlinear transcendental equations (2) is to use an iterative method such as the Newton-Raphson method [8][9][10][11]. In contrast to iterative methods, here a new approach is considered that gives all possible solutions and requires significantly less computational effort than the approach in [3]. To proceed with the new methodology, first let $s = 5$, and define $x_i = \cos(\theta_i)$ for $i = 1, \dots, 5$. Using standard trigonometric identities the conditions (2) become

$$\begin{aligned} p_1(x) &\triangleq x_1 + x_2 + x_3 + x_4 + x_5 - m = 0 \\ p_5(x) &\triangleq \sum_{i=1}^5 (5x_i - 20x_i^3 + 16x_i^5) = 0 \\ p_7(x) &\triangleq \sum_{i=1}^5 (-7x_i + 56x_i^3 - 112x_i^5 + 64x_i^7) = 0 \\ p_{11}(x) &\triangleq \sum_{i=1}^5 (-11x_i + 220x_i^3 - 1232x_i^5 + 2816x_i^7 \\ &\quad - 2816x_i^9 + 1024x_i^{11}) = 0 \\ p_{13}(x) &\triangleq \sum_{i=1}^5 (13x_i - 364x_i^3 + 2912x_i^5 - 9984x_i^7 + 16640x_i^9 \\ &\quad - 13312x_i^{11} + 4096x_i^{13}) = 0 \end{aligned}$$

where $x = (x_1, x_2, x_3, x_4, x_5)$ and $m \triangleq V_1 / (4V_{dc}/\pi)$. The modulation index is $m_a = m/s = V_1 / (s4V_{dc}/\pi)$ (Each inverter has a dc source of V_{dc} so that the maximum output voltage of the multilevel inverter is sV_{dc} . A square wave of amplitude sV_{dc} results in the maximum fundamental output possible of $V_{1\max} = 4sV_{dc}/\pi$ so $m_a \triangleq V_1/V_{1\max} = V_1 / (s4V_{dc}/\pi) = m/s$)

This is a set of five equations in the five unknowns x_1, x_2, x_3, x_4, x_5 . Further, the solutions must satisfy $0 \leq x_5 < \dots < x_2 < x_1 \leq 1$. This development has resulted in a set of polynomial equations rather than trigonometric equations. In previous work [1][2][3], the authors considered the three dc source case (7 levels) and solved the corresponding system of three equations in three unknowns using elimination theory by computing the resultant polynomial of the system (see [12] where polynomial systems

were also used). It turns out this procedure can be used for the four dc source case (9 levels), but requires several hours of computation on a Pentium III. However, when one goes to five dc sources (11 levels), the computations using contemporary computer algebra software tools, e.g., the **Resultant** command in MATHEMATICA [13]) on a Pentium III (512 Mb RAM) appear to reach their limit (i.e., the authors were unable to get a solution before the computer gave “out of memory” error messages). This computational complexity is because the degrees of the polynomials are large which in turn requires the *symbolic* computation of the determinant of large $n \times n$ matrices.

Here (cf. [3]) a new approach to solving the system is presented which greatly reduces the computational burden. Specifically, the *theory of symmetric polynomials* [4][14] is exploited to obtain a new set of relatively low degree polynomials whose resultants can easily be computed using existing computer algebra software tools. Further, in contrast to results reported in the literature that use iterative numerical techniques to solve these type of equations (e.g., [15]), the approach here produces all possible solutions.

IV. SOLVING POLYNOMIAL EQUATIONS

For the purpose of exposition, the three source (7 level) multilevel inverter will be used to illustrate the approach. The conditions are then

$$\begin{aligned} p_1(x) &\triangleq x_1 + x_2 + x_3 - m = 0, & m &\triangleq \frac{V_1}{4V_{dc}/\pi} \\ p_5(x) &\triangleq \sum_{i=1}^3 (5x_i - 20x_i^3 + 16x_i^5) = 0 \\ p_7(x) &\triangleq \sum_{i=1}^3 (-7x_i + 56x_i^3 - 112x_i^5 + 64x_i^7) = 0. \end{aligned} \quad (3)$$

Eliminating x_3 by substituting $x_3 = m - (x_1 + x_2)$ into p_5, p_7 gives

$$\begin{aligned} p_5(x_1, x_2) &= 5x_1 - 20x_1^3 + 16x_1^5 + 5x_2 - 20x_2^3 + 16x_2^5 \\ &\quad + 5(m - x_1 - x_2) - 20(m - x_1 - x_2)^3 \\ &\quad + 16(m - x_1 - x_2)^5 \\ p_7(x_1, x_2) &= -7x_1 + 56x_1^3 - 112x_1^5 + 64x_1^7 - 7x_2 + 56x_2^3 \\ &\quad - 112x_2^5 + 64x_2^7 - 7(m - x_1 - x_2) \\ &\quad + 56(m - x_1 - x_2)^3 - 112(m - x_1 - x_2)^5 \\ &\quad + 64(m - x_1 - x_2)^7 \end{aligned} \quad (4)$$

where

$$\begin{aligned} \deg_{x_1} \{p_5(x_1, x_2)\} &= 4, \deg_{x_2} \{p_5(x_1, x_2)\} = 4 \\ \deg_{x_1} \{p_7(x_1, x_2)\} &= 6, \deg_{x_2} \{p_7(x_1, x_2)\} = 6 \end{aligned} \quad (5)$$

A. Elimination Using Resultants

In order to explain the computational issues with finding the zero sets of polynomial systems, a brief discussion of the procedure to solve such systems is now given. The question

at hand is “Given two polynomial equations $a(x_1, x_2) = 0$ and $b(x_1, x_2) = 0$, how does one solve them simultaneously to eliminate (say) x_2 ?”. A systematic procedure to do this is known as *elimination theory* and uses the notion of *resultants* [4][5]. Briefly, one considers $a(x_1, x_2)$ and $b(x_1, x_2)$ as polynomials in x_2 whose coefficients are polynomials in x_1 . Then, for example, letting $a(x_1, x_2)$ and $b(x_1, x_2)$ have degrees 3 and 2, respectively in x_2 , they may be written in the form

$$\begin{aligned} a(x_1, x_2) &= a_3(x_1)x_2^3 + a_2(x_1)x_2^2 + a_1(x_1)x_2 + a_0(x_1) \\ b(x_1, x_2) &= b_2(x_1)x_2^2 + b_1(x_1)x_2 + b_0(x_1). \end{aligned}$$

The $n \times n$ *Sylvester* matrix, where $n = \deg_{x_2} \{a(x_1, x_2)\} + \deg_{x_2} \{b(x_1, x_2)\} = 3 + 2 = 5$, is defined by

$$S_{a,b}(x_1) = \begin{bmatrix} a_0(x_1) & 0 & b_0(x_1) & 0 & 0 \\ a_1(x_1) & a_0(x_1) & b_1(x_1) & b_0(x_1) & 0 \\ a_2(x_1) & a_1(x_1) & b_2(x_1) & b_1(x_1) & b_0(x_1) \\ a_3(x_1) & a_2(x_1) & 0 & b_2(x_1) & b_1(x_1) \\ 0 & a_3(x_1) & 0 & 0 & b_2(x_1) \end{bmatrix}.$$

The *resultant* polynomial is then defined by

$$r(x_1) = \text{Res} \left(a(x_1, x_2), b(x_1, x_2), x_2 \right) \triangleq \det S_{a,b}(x_1) \quad (6)$$

and is the result of solving $a(x_1, x_2) = 0$ and $b(x_1, x_2) = 0$ simultaneously for x_1 , i.e., eliminating x_2 . See the Appendix for an explanation of this fact. The point here is that as the degrees of the polynomials increase, the size of the corresponding Sylvester matrix increases and therefore the symbolic computation of its determinant becomes much more computationally intensive.

B. Symmetric Polynomials

Consider once again the system of polynomial equations (4). In [3] (see also [1][2]) the authors computed the resultant polynomial of the pair $\{p_5(x_1, x_2), p_7(x_1, x_2)\}$ to obtain the solutions to (3). This involved setting up a 10×10 Sylvester matrix ($10 = \deg_{x_2} \{p_5(x_1, x_2)\} + \deg_{x_2} \{p_7(x_1, x_2)\}$) and then computing its determinant to obtain the resultant polynomial $r(x_1)$ whose degree was 22.

However, as one adds more dc sources to the multilevel inverter, the degrees of the polynomials go up rapidly. For example, in the case of four dc sources, the final step of the method requires computing (symbolically) the determinant of a 27×27 Sylvester matrix to obtain a resultant polynomial of degree 221.

In the case of five sources, using this method, the authors were only able to get the system of five polynomial equations in five unknowns to reduce to three equations in three unknowns. The computation to get it down to two equations in two unknowns requires the symbolic computation of the determinant of a 33×33 Sylvester matrix. To get around this computational difficulty, a new approach is developed here which exploits the fact that the polynomials are symmetric.

The polynomials $p_1(x), p_2(x), p_3(x)$ in (3) are *symmetric polynomials* [14][16], that is,

$$p_i(x_1, x_2, x_3) = p_i(x_{\pi(1)}, x_{\pi(2)}, x_{\pi(3)}) \text{ for all } i = 1, 2, 3$$

and any permutation $\pi(\cdot)^1$. Define the *elementary symmetric functions* (polynomials) s_1, s_2, s_3 as

$$\begin{aligned} s_1 &\triangleq x_1 + x_2 + x_3 \\ s_2 &\triangleq x_1x_2 + x_1x_3 + x_2x_3 \\ s_3 &\triangleq x_1x_2x_3. \end{aligned} \quad (7)$$

A basic theorem of symmetric polynomials is that they can be rewritten in terms of the elementary symmetric functions [14][16] (This is easy to do using the `SymmetricReduction` command in MATHEMATICA [13]). In the case at hand, it follows that with $s = (s_1, s_2, s_3)$ and using (7), the polynomials (3) become

$$\begin{aligned} p_1(s) &= s_1 - m \\ p_5(s) &= 5s_1 - 20s_1^3 + 16s_1^5 + 60s_1s_2 - 80s_1^3s_2 \\ &\quad + 80s_1s_2^2 - 60s_3 + 80s_1^2s_3 - 80s_2s_3 \\ p_7(s) &= -7s_1 + 56s_1^3 - 112s_1^5 + 64s_1^7 - 168s_1s_2 \\ &\quad + 560s_1^3s_2 - 448s_1^5s_2 - 560s_1s_2^2 + 896s_1^3s_2^2 \\ &\quad - 448s_1s_2^3 + 168s_3 - 560s_1^2s_3 + 448s_1^4s_3 \\ &\quad + 560s_2s_3 - 1344s_1^2s_2s_3 + 448s_2^2s_3 + 448s_1s_3^2 \end{aligned} \quad (8)$$

One uses $p_1(s) = s_1 - m = 0$ to eliminate s_1 so that

$$\begin{aligned} q_5(s_2, s_3) &\triangleq p_5(m, s_2, s_3) = 5m - 20m^3 + 16m^5 + 60ms_2 \\ &\quad - 80m^3s_2 + 80ms_2^2 - 60s_3 + 80m^2s_3 - 80s_2s_3 \\ q_7(s_2, s_3) &\triangleq p_7(m, s_2, s_3) = -7m + 56m^3 - 112m^5 \\ &\quad + 64m^7 - 168ms_2 + 560m^3s_2 - 448m^5s_2 \\ &\quad - 560ms_2^2 + 896m^3s_2^2 - 448ms_2^3 + 168s_3 \\ &\quad - 560m^2s_3 + 448m^4s_3 + 560s_2s_3 \\ &\quad - 1344m^2s_2s_3 + 448s_2^2s_3 + 448ms_3^2 \end{aligned}$$

where

$$\begin{aligned} \deg_{s_2} \{q_5(s_2, s_3)\} &= 2, \quad \deg_{s_3} \{q_5(s_2, s_3)\} = 1 \\ \deg_{s_2} \{q_7(s_2, s_3)\} &= 3, \quad \deg_{s_3} \{q_7(s_2, s_3)\} = 2. \end{aligned}$$

The key point here is that degrees of these polynomials in s_2, s_3 are much less than the degrees of $p_5(x_1, x_2), p_7(x_1, x_2)$ in x_1, x_2 (see (5)). In particular, the Sylvester matrix of the pair $\{q_5(s_2, s_3), q_7(s_2, s_3)\}$ is 3×3 (if the variable s_3 is eliminated) rather than being 10×10 in the case of $\{p_5(x_1, x_2), p_7(x_1, x_2)\}$ in (4). Eliminating s_3 , the resultant polynomial $r_{q_5, q_7}(s_2)$ is given by

$$\begin{aligned} r_{q_5, q_7}(s_2) &\triangleq \text{Res}(q_5(s_2, s_3), q_7(s_2, s_3), s_3) \\ &= -16m \times \left(-1575 + 9800m^2 - 24080m^4 + 28160m^6 \right. \\ &\quad - 15360m^8 + 3072m^{10} - 10500s_2 + 56000m^2s_2 \\ &\quad - 103040m^4s_2 + 78080m^6s_2 - 20480m^8s_2 \\ &\quad - 19600s_2^2 + 89600m^2s_2^2 - 116480m^4s_2^2 + 46080m^6s_2^2 \\ &\quad \left. - 11200s_2^3 + 44800m^2s_2^3 - 35840m^4s_2^3 \right) \end{aligned}$$

¹That is, $p_i(x_1, x_2, x_3) = p_i(x_2, x_1, x_3) = p_i(x_3, x_2, x_1)$, etc.

which is only of degree 3 in s_2 . For each m , one would solve $r_{q_5, q_7}(s_2) = 0$ for the roots $\{s_{2i}\}_{i=1, \dots, 3}$. These roots are then used to solve $q_5(s_{2i}, s_3) = 0$ for the root s_{3i} resulting in the set of 3-tuples

$\{(s_1, s_2, s_3) \in \mathbb{C}^3 \mid (s_1, s_2, s_3) = (m, s_{2i}, s_{3i})_{i=1, \dots, 3}\}$ as the only possible solutions to (8).

C. Solving the Symmetric Polynomials

For each solution triple (s_1, s_2, s_3) , the corresponding values of (x_1, x_2, x_3) are required to obtain the switching angles. Consequently, the system of polynomial equations (7) must be solved for the x_i . To do so, one simply uses the resultant method to solve the system of polynomials

$$\begin{aligned} f_1(x_1, x_2, x_3) &= s_1 - (x_1 + x_2 + x_3) = 0 \\ f_2(x_1, x_2, x_3) &= s_2 - (x_1x_2 + x_1x_3 + x_2x_3) = 0 \\ f_3(x_1, x_2, x_3) &= s_3 - x_1x_2x_3 = 0. \end{aligned}$$

That is, one computes

$$\begin{aligned} r_1(x_2, x_3) &= \text{Res}(f_1(x_1, x_2, x_3), f_2(x_1, x_2, x_3), x_1) \\ &= -s_2 + s_1x_2 - x_2^2 + s_1x_3 - x_2x_3 - x_3^2 \\ r_2(x_2, x_3) &= \text{Res}(f_1(x_1, x_2, x_3), f_3(x_1, x_2, x_3), x_1) \\ &= -s_3 + s_1x_2x_3 - x_2^2x_3 - x_2x_3^2 \end{aligned}$$

so that

$$\begin{aligned} r(x_3) &= \text{Res}(r_1(x_2, x_3), r_2(x_2, x_3), x_2) \\ &= (s_3 - s_2x_3 + s_1x_3^2 - x_3^3)^2. \end{aligned} \quad (9)$$

The procedure is to substitute the solutions of (8) into (9) and solve for the roots $\{x_{3i}\}$. For each x_{3i} , one then solves $r_1(x_2, x_{3i})$ for the roots x_{2j} . Finally, one solves $f_1(x_1, x_{2j}, x_{3i}) = 0$ for x_{1j} to get the triples $\{(x_1, x_2, x_3) = (x_{1j}, x_{2j}, x_{3i}), i = 1, 2, 3, j = 1, 2\}$ as the only possible solutions to (3). This finite set of possible solutions can then be checked as to which are solutions of (3) satisfying $0 \leq x_3, x_2, x_1 \leq 1$.

V. COMPUTATIONAL RESULTS

Using the fundamental switching scheme of Figure 2, the solutions of (2) were computed using the method described above. These solutions are plotted in Figure 3 versus the parameter m . As the plots show, for m in the intervals $[2.21, 3.66]$ and $[3.74, 4.23]$ as well as $m = 1.88, 1.89$, the output waveform can have the desired fundamental with the 5th, 7th, 11th, 13th harmonics absent. Further, in the subinterval $[2.53, 2.9]$ two sets of solutions exist while in the subinterval $[3.05, 3.29]$, there are three sets of solutions. In the case of multiple solution sets, one would typically choose the set that gives the lowest total harmonic distortion (THD). In those intervals for which no solutions exist, one must use a different switching scheme (see [17] for a discussion on such possibilities).

The corresponding total harmonic distortion (THD) was computed out to the 31st according to

$$THD = \sqrt{(V_5^2 + V_7^2 + V_{11}^2 + V_{13}^2 + V_{17}^2 + \dots + V_{31}^2) / V_1^2}$$

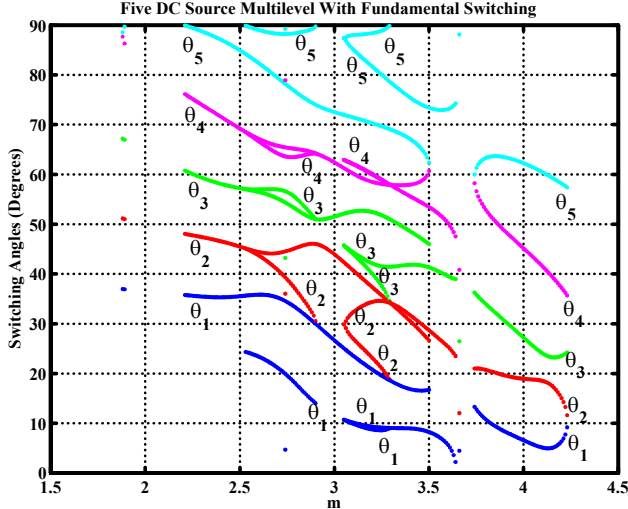

Fig. 3. Switching angles vs m for the 5 dc source multilevel converter ($m_a = m/s$ with $s = 5$).

where $V_n = (4V_{dc}/n\pi) (\cos(n\theta_1) + \cos(n\theta_2) + \dots + \cos(n\theta_s))$ is the amplitude of the n^{th} harmonic term of (1). The THD versus m is plotted in Figure 4 for each of the solution sets shown in Figure 3. As this figure shows, one can choose a particular solution for the switching angles such that the THD is 6.5% or less for $2.25 \leq m \leq 4.23$ ($0.45 \leq m_a \leq 0.846$). For those values of m for which mul-

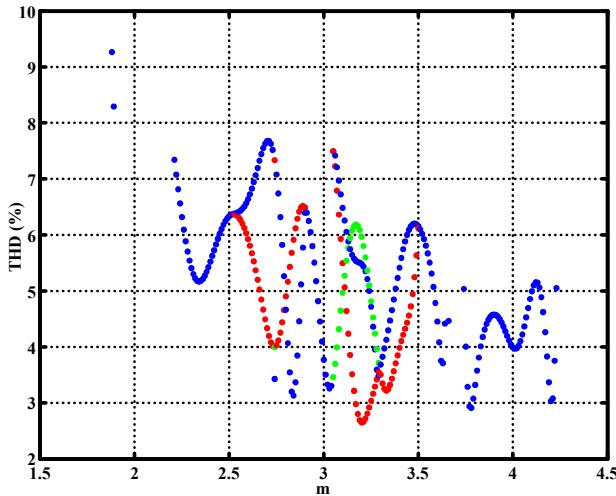

Fig. 4. The total harmonic distortion versus m for each solution set ($m_a = m/s$ with $s = 5$).

tipple solution sets exist, an appropriate choice is the one that results in the lowest THD.

VI. EXPERIMENTAL RESULTS

The same experimental setup described in [3] was used for this work. It is a three-phase 11-level (5 dc sources) wye-connected cascaded inverter using 100 V, 70 A MOSFETs as the switching devices [18]. A battery bank of

15 SDCSs of 36 V dc each feed the inverter (5 SDCSs per phase). In this work, the RT-LAB real-time computing platform from *Opal-RT-Technologies Inc.* [19] was used to interface the computer (which generates the logic signals) to the inverter. This system allows one to implement the switching algorithm as a lookup table in SIMULINK which is then converted to C code using RTW (real-time workshop) from *Mathworks*. The RT-LAB software provides icons to interface the SIMULINK model to the digital I/O board and converts the C code into executables. The step size for the real time implementation was 32 microseconds. This small step was used to obtain an accurate resolution for implementing the switching times. Using the XHP (extreme high performance) option in RT-LAB as well as the multi-processor option to spread the computation between two processors, an execution time of 32 microseconds can be achieved.

Note that while the calculations for the lookup table of Figure 3 require some offline computational effort, the real-time implementation is accomplished by putting the data (i.e., Figure 3) in a lookup table and therefore does not require high computational power for implementation.

The multilevel converter was attached to a three phase induction motor with the following nameplate data: Rated hp is 1/3 hp, rated current is 1.5 A, rated speed is 1725 rpm, rated voltage 208 V (RMS line-to-line @ 60 Hz).

In the experiment reported here, $m = 3.2$ was chosen to produce a fundamental voltage of $V_1 = m(4V_{dc}/\pi) = 3.2(4 \times 36/\pi) = 146.7$ V along with $f = 60$ Hz. As can be seen in Figure 4, there are three different solution sets for $m = 3.2$. The solution set that gave the smallest THD (= 2.65% see Figure 4) was used. Figure 5 shows the phase a voltage and its corresponding FFT showing that the 5^{th} , 7^{th} , 11^{th} and 13^{th} are absent from the waveform as predicted. The THD of the line-line voltage was computed using the data in Figure 5 and was found to be 2.8%, comparing favorably with the value of 2.65% predicted in Figure 4. Figure 6 contains a plot of both the phase a current and its corresponding FFT showing that the harmonic content of the current is much less than the voltage due to the filtering by the motor's inductance. The THD of this current waveform was computed using the FFT data and was found to be 1.9%.

VII. CONCLUSIONS

A procedure to eliminate harmonics in a multilevel inverter has been given which exploits the properties of the transcendental equations that define the harmonic content of the converter output. Specifically, it was shown that one can transform the transcendental equations into symmetric polynomials which are then further transformed into another set of polynomials in terms of the elementary symmetric functions. This formulation resulted in a drastic reduction in the degrees of the polynomials that characterize the solution. Consequently, the computation of solutions of this final set of polynomial equations was easily done using elimination theory (resultants) as the required symbolic computations were well within the capabilities of contem-

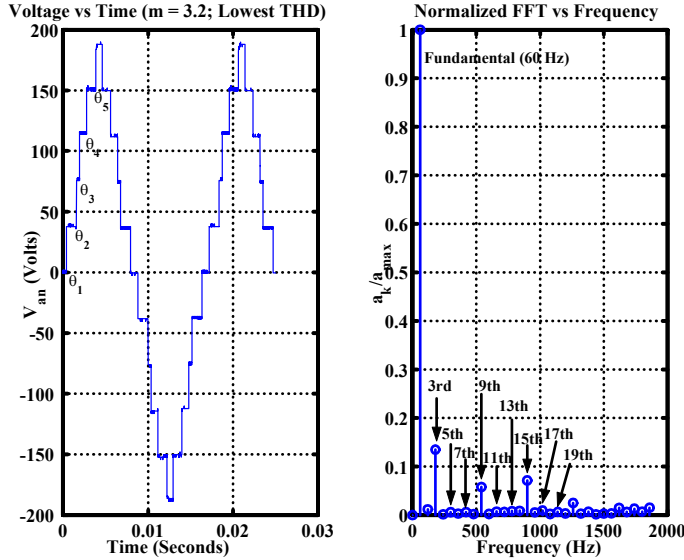

Fig. 5. Phase a output voltage waveform ($m = 3.2$) using the solutions set with the lowest THD and its normalized FFT.

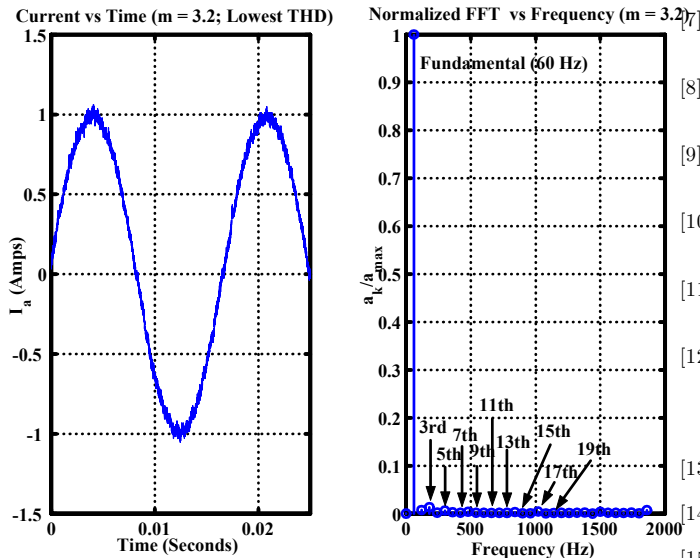

Fig. 6. Phase a current corresponding to the voltage in Figure 5 and its normalized FFT.

porary computer algebra software tools. This methodology resulted in the complete characterization of the solutions to the harmonic elimination problem. That is, for each m , it produces *all* possible solutions or it shows that no solution exists. This is in contrast to iterative numerical techniques such as Newton-Raphson, optimization software, etc. (for example, see [15],[20]) where one gets only one solution or no solution and is left to ponder whether a solution exists or not. Experiments were performed and the data presented corresponded well with the predicted results.

VIII. ACKNOWLEDGEMENTS

Dr. Tolbert would like to thank the National Science Foundation for partially supporting this work through contract NSF ECS-0093884. Drs. Chiasson and Tolbert would like to thank Oak Ridge National Laboratory for partially supporting this work through the UT/Battelle contract no. 4000007596.

REFERENCES

- [1] J. Chiasson, L. M. Tolbert, K. McKenzie, and Z. Du, "Eliminating harmonics in a multilevel inverter using resultant theory," in *Proceedings of the IEEE Power Electronics Specialists Conference*, pp. 503–508, June 2002. Cairns, Australia.
- [2] J. Chiasson, L. M. Tolbert, K. McKenzie, and Z. Du, "Real time implementation issues for a multilevel inverter," in *Proceedings of the 2002 ELECTRIMACS Conference*, August 2002. Montreal Canada.
- [3] J. Chiasson, L. M. Tolbert, K. McKenzie, and Z. Du, "Control of a multilevel converter using resultant theory," *IEEE Transactions on Control System Technology*, vol. 11, pp. 345–354, May 2003.
- [4] D. Cox, J. Little, and D. O'Shea, *IDEALS, VARIETIES, AND ALGORITHMS An Introduction to Computational Algebraic Geometry and Commutative Algebra, Second Edition*. Springer-Verlag, 1996.
- [5] Joachim von zur Gathen and Jürgen Gerhard, *Modern Computer Algebra*. Cambridge University Press, 1999.
- [6] D. Cox, J. Little, and D. O'Shea, *Using Algebraic Geometry*. Springer-Verlag, 1998.
- [7] J. S. Lai and F. Z. Peng, "Multilevel converters - A new breed of power converters," *IEEE Transactions on Industry Applications*, vol. 32, pp. 509–517, May/June 1996.
- [8] L. M. Tolbert and T. G. Habetler, "Novel multilevel inverter carrier-based PWM methods," *IEEE Transactions on Industry Applications*, vol. 35, pp. 1098–1107, Sept./Oct. 1999.
- [9] L. M. Tolbert, F. Z. Peng, and T. G. Habetler, "Multilevel converters for large electric drives," *IEEE Transactions on Industry Applications*, vol. 35, pp. 36–44, Jan./Feb. 1999.
- [10] L. M. Tolbert, F. Z. Peng, and T. G. Habetler, "Multilevel PWM methods at low modulation indexes," *IEEE Transactions on Power Electronics*, vol. 15, pp. 719–725, July 2000.
- [11] T. Cunyngham, "Cascade multilevel inverters for large hybrid-electric vehicle applications with variant DC sources," Master's thesis, The University of Tennessee, 2001.
- [12] J. Sun and I. Grotstollen, "Pulsewidth modulation based on real-time solution of algebraic harmonic elimination equations," in *Proceedings of the 20th International Conference on Industrial Electronics, Control and Instrumentation IECON*, vol. 1, pp. 79–84, 1994.
- [13] S. Wolfram, *Mathematica, A System for Doing Mathematics by Computer, Second Edition*. Addison-Wesley, 1992.
- [14] M. Mignotte and D. Ștefănescu, *Polynomials: An Algorithmic Approach*. Springer-Verlag, 1999.
- [15] P. N. Enjeti, P. D. Ziogas, and J. F. Lindsay, "Programmed PWM techniques to eliminate harmonics: A critical evaluation," *IEEE Transactions Industry Applications*, vol. 26, pp. 302–316, March/April 1990.
- [16] C. K. Yap, *Fundamental Problems of Algorithmic Algebra*. Oxford University Press, 2000.
- [17] J. Chiasson, L. M. Tolbert, K. McKenzie, and Z. Du, "Harmonic elimination in multilevel converters," in *Proceedings of the 7th IASTED International Multi-Conference Power and Energy Systems PES2003*, pp. 284–289, February 2003. Palm Springs, CA.
- [18] L. M. Tolbert, F. Z. Peng, T. Cunyngham, and J. Chiasson, "Charge balance control schemes for cascade multilevel converter in hybrid electric vehicles," *IEEE Transactions on Industrial Electronics*, vol. 49, pp. 1058–1064, October 2002.
- [19] Opal-RT Technologies, "RTLab," 2001. See <http://www.opal-rt.com/>.
- [20] R. Lund, M. D. Manjrekar, P. Steimer, and T. A. Lipo, "Control strategies for a hybrid seven-level inverter," in *Proceedings of the European Power Electronic Conference*, September 1999. Lausanne, Switzerland.