

Dynamic Security Margin Estimation with Preventive Control Using Artificial Neural Networks

A. Sittithumwat and K. Tomsovic

School of Electrical Engineering and Computer Science, Washington State University,
P. O. Box 642752, Pullman, WA 99164-2752, USA
Fax: 1-509-335-3818. Email address: tomsovic@eecs.wsu.edu

Abstract

On-line dynamic security assessment (DSA) is challenging using conventional techniques because most DSA approaches use detailed mathematical models of the system that are computationally intensive and time-consuming. In this paper, a method based on Artificial Neural Networks (ANN) is developed to estimate the security margin. The security margin for a given power system is obtained by applying standard operations criteria for transient response to off-line time simulations. These simulations then form a database that can be used to train a pattern matching approach, such as, ANNs. Feature selection using statistical approaches is applied to overcome the dimensional problem of applying the ANN to larger systems. This method provides a fast and accurate tool to evaluate dynamic security. If the estimated security margin is less than requirements, then preventive control actions that guarantee dynamic security of the power system are needed. This is achieved by optimal rescheduling of the generation with given constraints on the network power flows and system security margins as estimated by the ANN. This requires a modified Optimal Power Flow (OPF) solution that allows the trained ANN to act as a security objective function. Numerical results on the New England 39-bus system validate the methodology.

1. Introduction

Modern power systems are large and complex systems operated under great economic pressures in the new competitive and deregulation environment. These pressures have forced power systems to be operated closer to security limits, limits that may not be well understood. Consequently, as evidenced by the recent spate of blackouts, power system security has become a major concern. Power System security is the ability of system to withstand sudden disturbances with minimum disruption to the quality of service. Examples of such disturbances are electric short circuit, change of transmission system configurations due to faults, loss of system components, line switching actions, or sudden load increase. For proper planning and operation, it means that after the disturbance occurs, the power system must meet two requirements: (1) surviving the ensuing transient and moving into an acceptable steady-state condition, and (2) in this new steady-state condition all components are operating within established limits [1]. The analysis used for the first requirement is Dynamic Security Assessment (DSA). The second requirement is known as Static Security Assessment (SSA). Several techniques are now available to

perform quickly and reliably SSA; however, DSA methods are still not fully developed and available.

DSA is comprised of both Transient Stability Assessment (TSA) including adequate damping and Voltage Security Assessment (VSA). TSA is a major concern in the assessment of multi-machine power systems. In particular, a fault or loss of a large generator can give rise to large electromechanical oscillations between generating units, which might lead to loss of synchronism in the system. VSA is associated with the increased loading of long transmission lines and insufficient local reactive power supply. These types of phenomena are characterized by a voltage drop gradual initially, and then subsequently a collapse. This paper focuses on transient stability.

The objectives of TSA are to assess the transient stability of a power system subject to a set of pre-defined contingencies, and to provide the operators with efficient control measures to assure the system transient stability while maintaining economic operation. TSA conventional techniques include direct methods, such as transient energy function (TEF) [2] and extended equal area criteria (EEAC) [3], and indirect methods using time domain simulation [4]. Direct methods have drawn much attention in the past since these methods can provide stability indices and have low computational requirements. Still, these methods require significant approximations that limit the modeling complexity. As a result, it is difficult to construct a reliable index. On the other hand, time domain simulation provides the most accurate approach for determining the transient stability of the system. This method allows flexible modeling of components. Still, time domain simulation is computationally intensive and not suitable for on-line application.

To overcome such shortcomings, pattern-matching methods have been proposed. These methods are driven by a large database of examples from the off-line studies. Among such approaches, the Artificial Neural Network (ANN) has been frequently proposed as since it possesses certain attractive features, including excellent generalization capabilities, superior noise rejection, and fast execution (most of the calculation occurs during the initial off-line training). The underlying principle consists of extracting the main off-line study information derived from time domain simulation, and organizing it into a neural network. This enables one to infer knowledge about new cases. It avoids cumbersome transient stability computations on-line, and allows transient stability assessment to be performed in a very short time. Several researchers have been pursuing improving the methodology for use as a reliable tool of on-line DSA [5-7].

As the system operating state changes throughout the day, DSA should be constantly in operation to detect when the security level falls below an acceptable level. In this situation, it is important for the system operators to make proper preventive measures to ensure the system returns to a secure state. Preventive control actions include generation rescheduling, network switching, reactive compensation and load curtailment. Generation rescheduling to improve transient stability has been explored for decades. In [3, 8-9], direct methods are proposed, where the sensitivities of the stability margin with respect to the change in control parameters, such as generator output, are used as guidance to select control measures. The concept of coherency was introduced in [10-11] as a measure for

the redispatch. In [12-13] optimization techniques are combined with the TEF to determine optimal rescheduling. In [14], the stability constraints are included in the optimal power flow (OPF) by converting the differential equation constraints into equivalent algebraic constraints. Pattern recognition and neural networks have also been used for preventive control schemes [15-16]. The transient stability functions, which are acquired by pattern recognition or neural network techniques, are applied as constraints of an optimization problem.

In this paper, a method based on ANNs is used to estimate the security margin. The security margin, i.e., the distance between the current operating point and the security limit, for a given power system is obtained by applying standard operations criteria for transient response to off-line time simulations. These simulations then form a database that can be used to train the ANN. Feature selection using statistical approaches is applied to overcome the dimensional problem of applying the ANN to larger systems. If the estimated security margin is less than requirements, then preventive control actions that assure dynamic security of the power system are needed. This is achieved by rescheduling the generation with the given constraints on the network power flows and the system security margins as estimated by the ANN. This requires a modified OPF solution that allows the trained ANN to act as a security objective function.

2. Problem formulation

Power system security assessment can be divided into two categories: classification and margin determination. Classification determines whether the system is secure or insecure for all pre-specified contingencies. Classification does not in itself indicate the distance from the operating condition to the insecure conditions. Security margin determination, on the other hand, involves finding this distance. Safe operating levels based on various system conditions are given in terms of a critical system operating parameter, e. g., loading of a certain power plant, the power flow at critical transmission interface, the voltage at given bus, and so on. In this paper, the power system security margin in response to all predefined contingencies is investigated for a given pre-contingency steady state of the system. The loading is varied to determine the security margin regarding the frequency deviation. The allowable margins and associated reliability criteria are based on the regional council (WECC) guidelines [17].

2.1 ANN for Stability Margin Assessment

Generally, pattern-matching approaches consist of data (training set) generation, feature selection, training process, and performance evaluation. Our focus here is on estimation of the loading margin (P margin) regarding transient frequency criteria. The frequency should not drop below 59.6 Hz for 6 cycles or more at a load bus. Note that the amount of additional load of a particular operating point that would violate the frequency criteria is called the loading margin to frequency deviation. The active and reactive power flow of all lines is used as the features in order to describe a system state. The ANN is trained using the data of the off-line operational studies.

2.1.1 Neuron network design

A feed-forward multi-layer ANN based on Levenberg-Marquardt and Bayesian Regulation backpropagation is chosen [18]. It includes three layers, one for the input, one for the hidden, and one for the output. The size of input is identified by the size of the input pattern. Similarly, the size of the output layer is determined by the number of the outputs. There is no exact criterion either for the number of hidden layers or for the number of neurons per hidden layer. Too many neurons can lead to memorization of the training data with the danger of losing the ability to generalize and predict. Data or training sets have to be representative of the different states of the power system because ANNs are good in interpolation but not extrapolation. This means that they need to cover the complete pattern space. Note that the routines from MATLAB neural network toolbox [19] are used.

2.1.2 Data generation

The training set is generated by considering several load levels and different generation unit patterns for a particular contingency. To determine the transient stability transfer limits or loading margins, a load-flow software package (IPFLOW [20]) is first executed for the given topology to find a satisfactory steady-state case. This steady-state case is then applied to initialize the network for a transient-stability simulation program (ETMSP [21]). When the simulation is finished, reliability criteria are applied to the results from ETMSP. The load and generation are modified accordingly and then the process iterated. This is repeated till the highest stable transfer level for an interface is found. In general, to find the security limit, the process must be repeated for different contingency types and location until the most constraining (i.e., lowest) transfer limit has been identified. Note that, in this paper, only one network topology is analyzed.

2.1.3 Feature selection

This stage can be considered a pre-processing step. This is an extremely important step, as selected features should characterize properly a variety of power system operating conditions. Generally, the dimension of the pattern vector is very large. The process of finding the most significant variables, eliminating redundancy and reducing the dimension of the pattern vector is called feature selection. Different methods based on statistical approaches are available for feature extraction (i.e., reducing the dimension of the input data vector). Here, parameters that may be applied to describe a system state are as follows:

- voltage magnitude and phase angle at each system bus,
- active and reactive power of each bus load,
- active and reactive power flow of all the lines,
- active and reactive power output of each generator plant.

The selection and extraction process should involve both engineering judgment and statistical analysis. The statistical approaches applied in the study are principal components analysis (also called Karhunen-Loeve expansion) and correlation coefficients

[18]. First, the principal component analysis method determines the eigenvectors corresponding to the largest eigenvalues of the auto-correlation matrix of training vectors as its principal components. The reduced training vectors are selected in direction of the most dominant eigenvectors. Subsequently, the correlation coefficients between the selected features and the computed security margin are determined for further reduction of input vector dimension. The ANN is then trained with this new set of reduced vectors. This extraction closely relates to the performance of a neural network and computation time since the fewer the number of features, the fewer samples required.

2.1.4 Splitting training data for estimation and validation

One of the simplest and most widely used means of avoiding overfitting, which can occur when training ANNs, is to divide the training data into two sets: an estimation set and a validation set. The optimum ratio r_{opt} that determines the split of the training data between estimation and validation sets is defined by

$$r_{opt} = 1 - \frac{\sqrt{2W-1}-1}{2(W-1)} \quad (1)$$

where r_{opt} is the estimation portion, W is the number of free parameters in the network with $N < W$, and N is the size of the training set [22].

2.2 Optimization Formulation for Preventive Rescheduling

Generation rescheduling is formulated as a constrained optimization problem as follows:

$$\max f(P_g) \quad (2)$$

Subject to:

$$P_g - P_d - P(V, \theta) = 0 \quad (3)$$

$$Q_g - Q_d - Q(V, \theta) = 0 \quad (4)$$

$$\sum_{i=1}^{Ng} (P_{g_i} - P_{g_i}^0) = 0 \quad (5)$$

$$\underline{P}_g \leq P_g \leq \overline{P}_g \quad (6)$$

$$\underline{V} \leq V \leq \overline{V} \quad (7)$$

$$\underline{Q}_g \leq Q_g \leq \overline{Q}_g \quad (8)$$

where $f(\cdot)$ is the trained ANN function, which maps the power flows of selected lines (resulting from the feature extraction) to the security margin, and P_g is the vector of active power generation output with upper bound $\overline{P_g}$ and lower bound $\underline{P_g}$. Since $f(\cdot)$ does not map P_g to the security margin directly, P_g is converted to line flows through (3) and (4), which are the active and reactive power flow equations respectively, and then line flows are extracted appropriately for the trained ANN function. Equation (5) is the load balance constraint where N_g is the number of generator buses; P_{g_i} is the i^{th} element of P_g ; $P_{g_i}^0$ is the i^{th} element of P_g^0 , a vector representing the generation before the rescheduling. Q_g is the vector of reactive power generation output with upper bound $\overline{Q_g}$ and lower bound $\underline{Q_g}$, $P(V, \theta)$ and $Q(V, \theta)$ are vectors of real and reactive power injections, and V and θ are vectors of bus voltage magnitudes and angles with upper limit \overline{V} and lower limit \underline{V} . Note that the objective function in this formulation does not have an analytical expression. So the search for maxima relies entirely on functional evaluations. In this paper, an optimization routine, based on Sequential Quadratic Programming method from MATLAB optimization toolbox [23], is applied.

2.3. Summary of Approach

The proposed approach includes the transient stability assessment based on ANN and the preventive rescheduling. The procedures are as follows:

1. Evaluate the worst case regarding to security margin (i.e., lowest margin) using the trained ANN by considering all pre-specified contingencies, e.g., three phase faults on branches of a power system network.
2. If the security margin of the worst case is below an unacceptable level, then the preventive rescheduling optimization in section 2.2 is exercised to improve that security margin.
3. The rescheduling is then checked with a full analysis of the security margin to verify the margin estimate.

3. Numerical example

3.1 Example of Security Margin Estimation

To illustrate the proposed approach, the 39-bus New England test system is chosen. The system is divided into two zones, a load center with only load buses including buses 17, 18, and 27 with three tie lines 3-18, 16-17, and 26-27 as shown in Figure 1. The other zone contains all the remaining load and generation buses. The focus of the study here is the power flow at the interface of this load center.

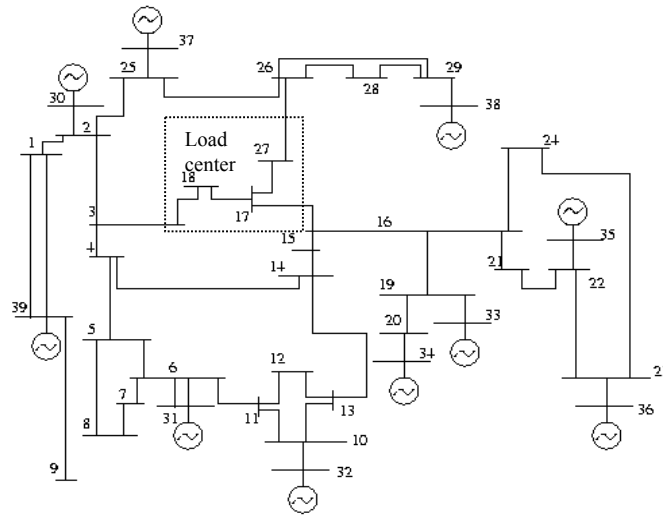

Figure 1. New England test system

Pattern number	Unit 30 (MW)	Unit 31 (MW)	Unit 32 (MW)	Unit 33 (MW)	Unit 34 (MW)	Unit 35 (MW)	Unit 36 (MW)	Unit 37 (MW)	Unit 38 (MW)	Unit 39 (MW)
1	250.0	573.66	650.0	632.0	508.0	650.0	560.0	540.0	830.0	1000.0
2	308.6	583.9	655.2	599.8	462.5	646.4	565.8	555.1	808.3	1008.0
3	256.8	531.2	830.72	599.2	472.0	839.20	482.15	663.0	719.38	800.0
4	288.9	597.6	696.46	599.2	472.0	710.4	524.88	524.88	829.35	950.0
5	347.56	597.6	674.1	599.2	472.0	674.1	524.88	524.88	829.35	950.0
6	363.69	579.67	653.88	581.22	607.7	653.88	509.13	509.13	804.47	930.89
7	280.2	579.7	653.9	581.2	607.7	653.9	509.1	509.1	804.5	1014.4
8	312.2	579.7	653.9	613.7	532.1	653.9	509.1	509.1	830.0	1000.0
9	280.23	579.67	653.88	623.74	554.00	653.88	509.13	509.13	830	1000.0
10	274.5	573.7	640.4	632.0	573.5	640.4	498.6	530.6	830.0	1000.0
11	274.5	573.7	640.4	632.0	583.5	640.4	498.6	520.6	830.0	1000.0
12	280.2	579.7	653.9	632.0	554.0	653.9	509.1	509.1	821.7	1000.0
13	319.2	579.7	653.9	608.7	525.1	653.9	509.1	514.1	830.0	1000.0
14	324.2	579.7	653.9	606.7	520.1	653.9	509.1	516.1	830.0	1000.0
15	334.2	579.7	653.9	606.7	515.1	646.9	499.1	523.1	835.0	1000.0
16	344.2	579.7	653.9	606.7	510.1	639.9	489.1	530.1	840.0	1000.0
17	354.2	579.7	653.9	606.7	505.1	632.9	479.1	537.1	845.0	1000.0
18	364.2	579.7	653.9	606.7	500.1	625.9	469.1	544.1	850.0	1000.0
19	374.2	584.7	653.9	601.7	492.1	618.9	459.1	552.1	857.0	1000.0
20	384.2	589.7	653.9	596.7	484.1	611.9	449.1	560.1	864.0	1000.0

Table 1. The generation schedule used to obtain training set

The P margin is decided by increasing the active power of the load center step by step over the base case until there is a violation to the reliability criteria (in this study either frequency excursion or inadequate damping). The smallest step used is 25 MW, and the total load for the base case is 6000 MW. The generator schedules used in obtaining the

training set are given in Table 1. The entire data set consists of 1042 samples with 20% for testing and 30% for validation. The training and testing data are obtained from transient stability studies using commercial software packages, i.e., IPFLOW and ETMSP. Contingencies considered are three-phase faults on each line with the fault cleared in three cycles (0.05 seconds) by removal of the line. For each load level, there are 32 cases representing one base case and 31 (n-1) contingencies.

Training Method	Max error (MW/%)	Min error (MW/%)	Mean error (MW/%)	Mean Square error (MW ²)	Standard Deviation (MW)	Number of hidden neurons
Levenberg-Marquardt	7.4043, 4.2811%	0.0003 0.00006%	0.6850 0.2622%	1.3102	1.1036	25
Bayesian Regulation	5.5207 7.3437%	0.0010 0.0005%	0.5878 0.2683%	0.6710	0.8193	25

Table 2. Security assessment result of the 39-bus system

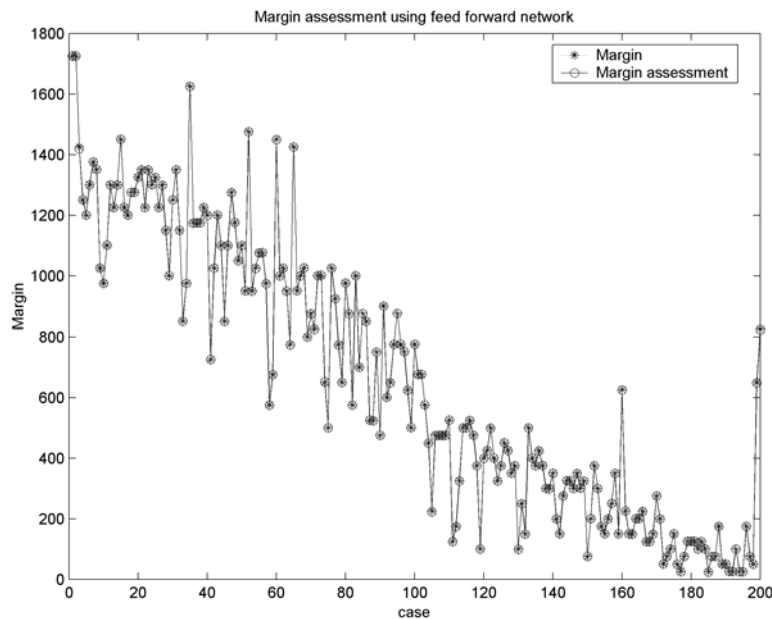

Figure 2. Margin estimator performance on the 39-bus system

Initially, there are 96 total features, i.e., the active and reactive power flow of all the lines. These reduce to 34 features using principal components analysis. Here, statistical correlation coefficients were exploited to further reduce the dimension of the pattern vector to 17 elements. An ANN with 25 neurons in the single hidden layer was implemented using Levenberg-Marquardt and Bayesian Regulation backpropagation. From the results shown in Table 2 and Figure 2, the estimated security margin agrees with

the results computed by the transient simulation program, and the performances of these two backpropagation methods are similar.

3.2 Example of Generation Rescheduling

To demonstrate the preventive rescheduling part, suppose that the security margin of base case must be improved. In the base case, the P margin of the worst case is 425 MW with three-phase fault on branch from bus 21 to 22. The rescheduling measure is applied using a heuristic method (as a means of comparison) and the proposed optimization method. The scheme of heuristic approach is based on the size of the frequency excursions of the generation units following the limiting contingencies. Those units with larger deviations will have their power outputs decreased, and that decreased amount of power output will be allocated to other units, which have relatively smaller deviations. In the optimization approach, two cases are considered regarding the generation schedule used in obtaining the training set. The generation schedules applied for optimization case I and case II are pattern numbers 1-10 and pattern numbers 1-20, respectively, shown in Table 1. The results are shown in Table 3.

Gen. unit no.	Base case gen. (MW)	Rescheduling using heuristic method (MW)	Rescheduling using optimization case I (MW)	Rescheduling using optimization case II (MW)
30	250.00	308.6	385.2	385.20
31	573.66	583.9	531.2	564.94
32	650.00	655.2	651.6	655.98
33	632.00	599.8	599.2	599.20
34	508.00	462.5	528.1	472.0
35	650.00	646.4	642.7	665.78
36	560.00	565.8	447.5	447.53
37	540.00	555.1	552.5	552.50
38	830.00	808.3	855.5	855.54
39	1000.00	1008.0	1000.0	995.00
Estimated P margin (MW)	-	-	801.38	964.16
Actual P margin (MW)	425	500	800	875
Worst case	Branch 21-22	Branch 21-22	Branch 16-17	Branch 16-17

Table 3. Generation rescheduling results of the 39-bus system

Note that, in Table 3, actual P margin refers to the power margin acquired using transient stability program (time domain simulation), and estimated P margin is the power margin obtained directly from the optimization. The results show that all methods can improve the stability margin of the base case, and the better ones result from the proposed optimization approach. From the results shown in Table 3, although there is a mismatch between actual margin, and estimated margin but the generation power output according to estimated margin does give a direction how to redispatch the generation units in order to improve the stability limit.

4. Conclusions

The estimated results obtained from ANN show that this technique is able to predict the security margin with a reasonable degree of accuracy. Prediction and generalization capabilities of these NNs provide a flexible mapping of input attributes to the single-valued space of the security margin. Since ANNs have high computation rates, parallel distributed processing, fault tolerance, and adaptive capability, they are an excellent alternative for real-time application. The ANN-based margin estimator can then be used to drive a preventive rescheduling scheme. The important point for this approach is that the estimator must be trained with appropriately dispatch patterns to not only estimate the margins but to cover different generation patterns. The numerical results for the test systems have shown that the technique improves the stability margin of the system for the set of contingencies. Still, research is required to make the algorithm more robust and general.

5. Acknowledgements

This work was supported in part through the Consortium for Electric Reliability Technology Solutions (CERTS), funded by the Assistant Secretary of Energy Efficiency and Renewable Energy, Office of Distributed Energy and Electricity Reliability, Transmission Reliability Program of the U.S. Department of Energy under Interagency Agreement No. DE-AI-99EE35075 with the National Science Foundation, and in part through PSerc a Nation Science Foundation I/UCRC.

6. References

- [1] IEEE Committee Report, "Dynamic Security Assessment Practices in North America," *IEEE Transactions on Power Systems*, Vol. 3, No. 3, 1988, pp. 1310-1321.
- [2] Fouad, A. A. and Vittal, V., *Power System Transient Stability Analysis Using the Transient Energy Function*, Prentice Hall, New Jersey, 1992.
- [3] Xue, Y. and Pavella, M., "Extended Equal-Area: An Analytical Ultra-Fast Method for Transient Stability Assessment and Preventive Control of Power Systems," *International journal of electrical power and energy systems*, Vol. 11, No. 2, 1989, pp. 131-149.
- [4] Tang, C. K., Graham, C. E., El-Kady, M., and Alden, R. T. H., "Transient Stability Index from Conventional Time Domain Simulation," *IEEE Transactions on Power Systems*, Vol. 9, No. 3, 1994, pp. 1524-1530.
- [5] Jensen, C. A., El-Sharkawi, M. A., and Marks, R. J. II, "Power System Security Assessment Using Neural Networks: Feature Selection Using Fisher Discrimination," *IEEE Transactions on Power Systems*, Vol. 16, No. 4, 2001, pp. 757-763.
- [6] Kumar, R., Ipahchi, A., Brandwajan, V., El-Sharkawi, M. A. and Cauley, G., "Neuron Networks for Dynamic Security Assessment of Large Scale Power Systems: Requirements Overview," *Proceedings of 1st International Forum on Applications of Neuron Networks to Power Systems*, Seattle, WA, July 1991, pp. 65-71.
- [7] ManSour, Y., Chang, A. Y., Tamby, J., Vaahedi, E., Corns, B. R., and El-Sharkawi, M. A., "Large Scale Dynamic Security Screening and Ranking Using Neuron Networks," *IEEE Transactions on Power Systems*, Vol. 12, No. 2, 1997, pp. 954-960.

- [8] Momoh, J. A. and Effiong, C. B., "Generation Rescheduling for Dynamic Security Enhancement for Multi-Area Power System," *IEEE International Conference on Systems, Man, and Cybernetics, Computational Cybernetics and Simulation*, Vol. 4, October 1997, pp. 3437-3442
- [9] Hashimoto, H., Taoka, H., Zhang, Y., and Zhang, B., "An Integrated Approach to Dynamic Security Assessment and Control of Power Systems," *Proceedings of International Conference on Power System Technology*, Vol. 3, December 2000, pp. 1269-1274.
- [10] Kuo, D. H. and Bose, A., "A Generation Rescheduling Method to Increase the Dynamic Security of Power Systems," *IEEE Transactions on Power Systems*, Vol. 10, No. 1, 1995, pp. 68-76.
- [11] Li, W. and Bose, A., "A coherency Based Rescheduling Method for Dynamic Security," *IEEE Transactions on Power Systems*, Vol. 13, No. 3, 1998, pp. 810-815.
- [12] Sterling, J., Pai, M. A., and Sauer, P. W., "A Methodology of Secure and Optimal Operation of a Power System for Dynamic Contingencies," *Electric Machines and Power Systems*, Vol. 19, 1991, pp. 639-655.
- [13] Fouad, A. A. and Jianzhong, T., "Stability Constrained Optimal Rescheduling of Generation," *IEEE Transactions on Power Systems*, Vol. 8, No. 1, 1993, pp. 105-112.
- [14] Gan, D., Thomas, R. J., and Zimmerman R. D., "Stability-Constrained Optimal Power Flow," *IEEE Transactions on Power Systems*, Vol. 15, No. 2, 2000, pp. 535-540.
- [15] Yamashiro, S., "On-Line Secure-Economic Preventive Control of Power Systems by Pattern Recognition," *IEEE Transactions on Power Systems*, Vol. 1, No. 3, 1986, pp. 214-219.
- [16] Miranda, V., Fidalgo, J. N., Pacas Lopes, J. A., and Almeida, L. B., "Real Time Preventive Actions for Transient Stability Enhancement with a Hybrid Neural Network – Optimization Approach," *IEEE Transactions on Power Systems*, Vol. 10, No. 2, 1995, pp. 1029-1035.
- [17] Western Electricity Coordinating Council, *Reliability Criteria*, April 2003.
- [18] Haykin, S., *Neural Networks a Comprehensive Foundation*, 2nd Edition, Prentice Hall, New Jersey, 1999.
- [19] *Neural Network Toolbox User's Guide*, The MathWorks, Natick, Massachusetts, January 2003.
- [20] *Interactive Power Flow Version 2.1*, Volume 2: User's Manual, Electric Power Research Institute (EPRI), Palo Alto, California, May 1994.
- [21] *Extended Transient-Midterm Stability Program (ETMSP): Version 3.1*, Volume 2: User's Manual (Revision 1), Electric Power Research Institute (EPRI), Palo Alto, California, May 1994.
- [22] Chen, L., Tomsovic, K., Bose A., and Stuart, R., "Estimating Power Transfer Margins for Voltage Security," *IEEE Transactions on Power Systems*, in revision.
- [23] *Optimization Toolbox User's Guide*, The MathWorks, Natick, Massachusetts, September 2003.