

ECE 301
Fall Semester 2005
HW # 3

wlg Due: October 4, 2005

Name _____
Print (last, first)

Use engineering paper. Work only on one side of the paper. Use this sheet as your cover sheet, placed on top of your work and stapled in the top left-hand corner. Number the problems at the top of the page, in the center of the sheet. **Do neat work. Underline your answers. Show how you got your equations. Be sure to show how you got your answers.** Each problem counts 10 points.

- (1) You are given the circuit shown below. Find C (capacitor value) so that the energy stored in the capacitor equals the energy stored in the inductor. Assume the circuit is in steady state.
Ans: On your own.

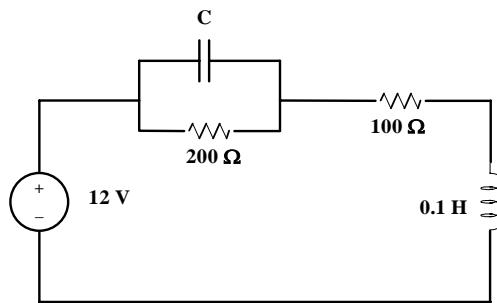

- (2) A certain DC voltage has been applied to terminals a-b in the circuit below. The circuit has reached steady state. (a) Determine V_{C1} . (b) Determine the voltage V_{ab} . Ans: $V_{C1}=4V$, $V_{ab}= 20V$.

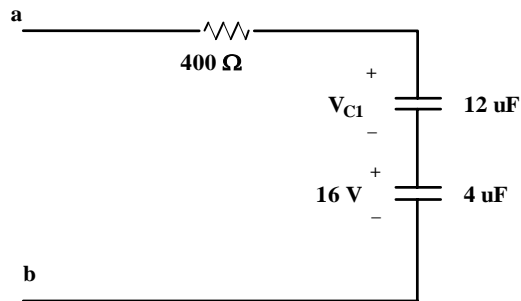

- (3) You are given the circuit below. The circuit has reached steady state. Find the following:
(a) V_c , (b) I_L , (c) W_c , (d) W_L . Ans: $V_c = 0$, $I_L = 2A$, $W_c = 0$, $W_L = 1 J$

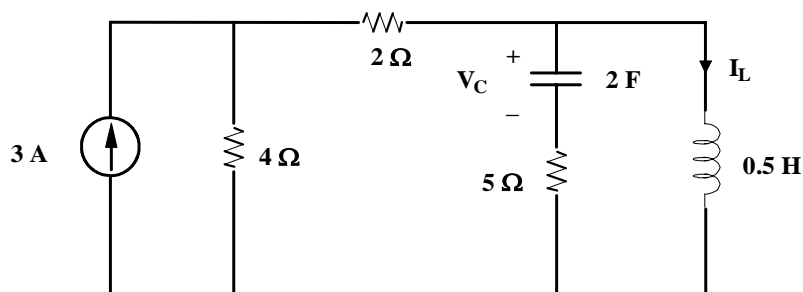

(4) You are given the circuit shown below. Find C_{eq} . Ans: On your own.

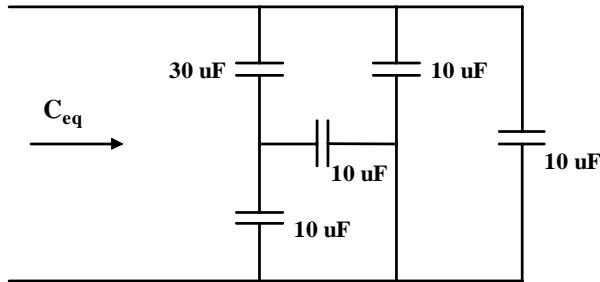

(5) You are given the following circuit. Find L so that $L_{ab} = 2$ mH. Ans: On your own.

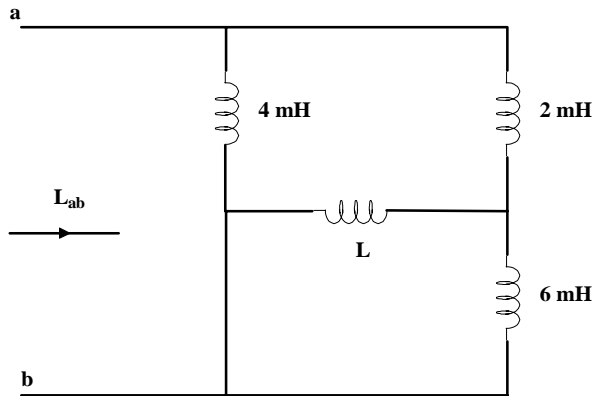

(6) You are given the circuit below. Assume the capacitors are initially uncharged. Find $v_o(t)$ for $t > 0$.

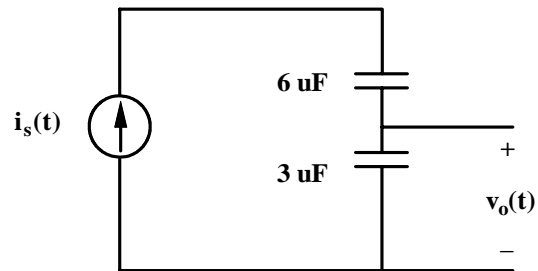
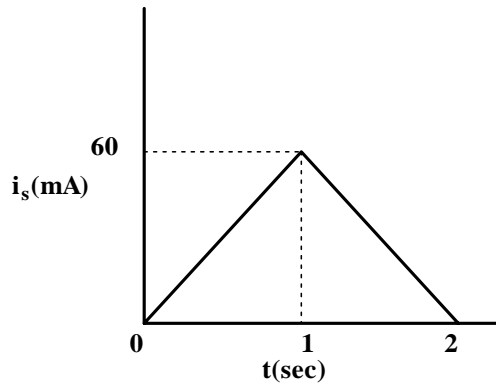

Ans:

$$v_o(t) = 10t^2 \cdot 10^3 \text{ V} \quad 0 \leq t \leq 1$$

$$v_o(t) = (40t - 10t^2 - 20) \cdot 10^3 \text{ V} \quad 1 \leq t \leq 2$$