

Desk Copy

ECE 301
Fall Semester, 2005
Test #3

wlg Version B

Name Green
Print (last, first)

Omit 1 2

Work the exam on your own engineering paper. Work on one side of your paper only. Attach your work to the back of this exam sheet and staple in the top left hand corner. You may omit either problem 1 or 2. Check which one you omit above. Each problem counts 25%.

(1) You are given the op amp circuit of Figure 1. Find the output voltage V_o .

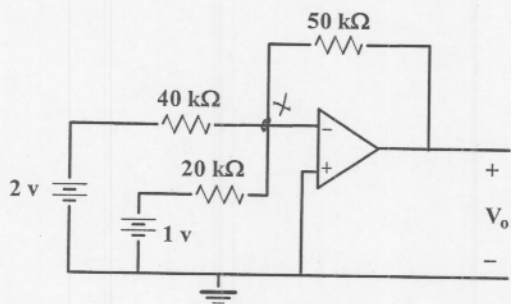

Figure 1: Circuit for problem 1.

(2) You are given the op amp circuit of Figure 2. Find the output voltage V_o .

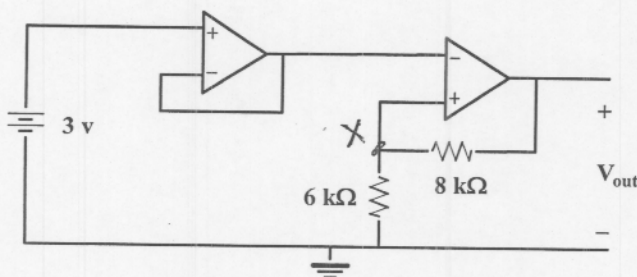

Figure 2: Circuit for problem 2.

(3) You are given the op amp configuration of Figure 3. Find the output voltage. The voltage will be in terms of V_1 and V_2 .

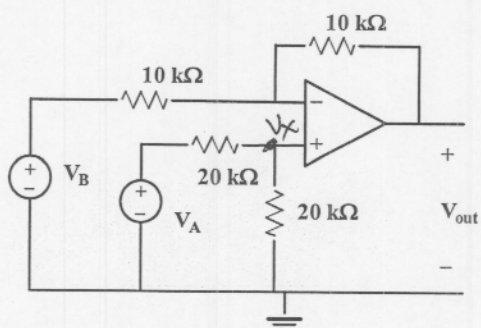

Figure 3: Circuit for problem 3.

(4) You are given the op amp circuit of Figure 4. Find the current I_o .

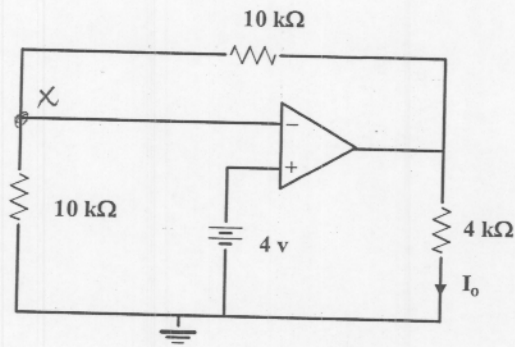

Figure 4: Circuit for problem 4.

(5) The frequency response magnitude of a certain filter is given in Figure 5. The filter response approaches one as ω approaches infinity. The response is zero at $\omega = 0$.

- Classify this filter as (i) low pass, (ii) high pass, (iii) band pass.
- What is the approximate cut-off frequency of the filter in rad/sec?
- Give an op amp circuit using one op amp (with two resistors and one capacitor) that will produce this frequency response. The capacitor is restricted to be $0.1 \mu\text{F}$. Give the op amp circuit and the values of R_1 and R_2 . Identify the output and input of your op amp circuit.
- Give the transfer function of your filter.

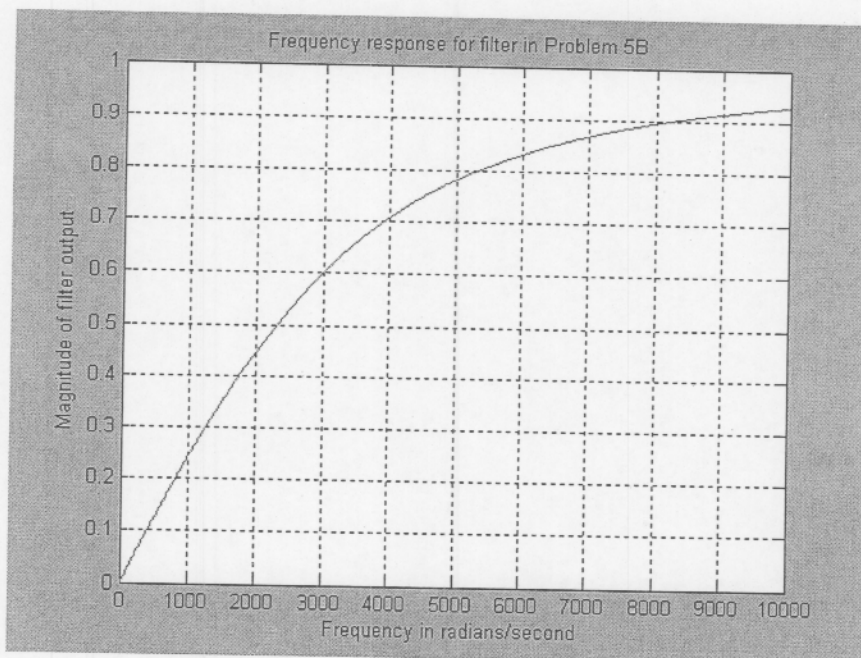
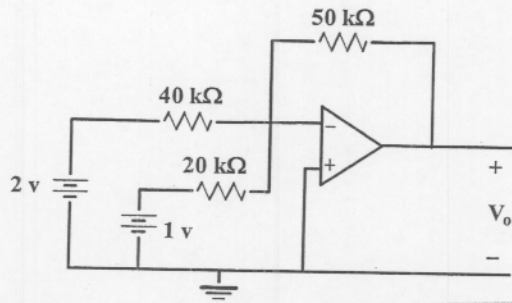

Figure 5: Frequency response magnitude for problem 5.

(1) You are given the op amp circuit of Figure 1. Find the output voltage V_o .



Writing a nodal equation at "x"

$$\frac{2}{40k} + \frac{1}{20k} + \frac{V_o}{50k} = 0$$

$$V_o = -5V$$

(2) You are given the op amp circuit of Figure 2. Find the output voltage V_o .

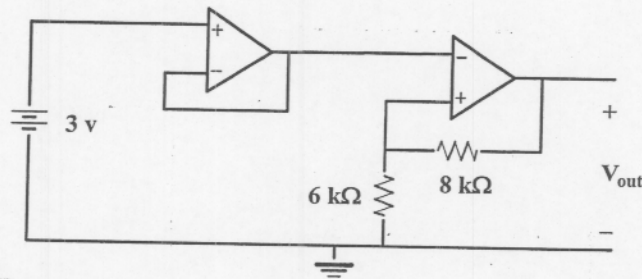

The voltage at "x" is 3V
writing a node equation,

$$\frac{3}{6k} + \frac{3 - V_o}{8k} = 0$$

$$12 + 9 - 3V_o = 0$$

$$V_o = \frac{21}{3} = 7$$

$$V_o = 7V$$

- (3) You are given the op amp configuration of Figure 3. Find the output voltage. The voltage will be in terms of V_1 and V_2 .

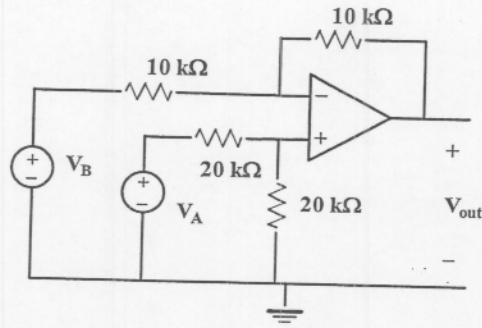

$$V_x = \frac{V_A \times 20}{20 + 20} = \frac{V_A}{2}$$

$$\frac{V_B - \frac{V_A}{2}}{10\text{ k}\Omega} + \frac{V_o - \frac{V_A}{2}}{10\text{ k}\Omega} = 0$$

$$2V_B - V_A + 2V_o - V_A = 0$$

$$V_o = V_A - V_B$$

- (4) You are given the op amp circuit of Figure 4. Find the current I_o .

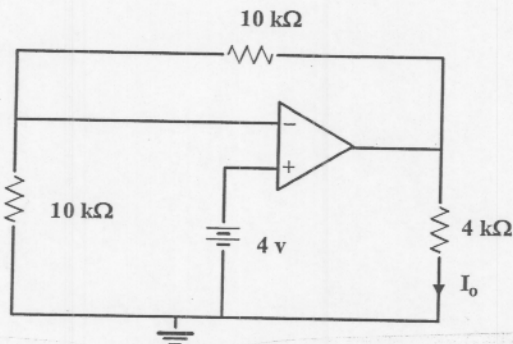

The voltage at "x" is 4 V
writing a node equation

$$\frac{4}{10\text{ k}\Omega} + \frac{4 - 4\text{ k}\Omega I_o}{10\text{ k}\Omega} = 0$$

$$I_o = 2\text{ mA}$$

(5) The frequency response magnitude of a certain filter is given in Figure 5. The filter response approaches one as ω approaches infinity. The response is zero at $\omega = 0$.

- Classify this filter as (i) low pass, (ii) high pass, (iii) band pass.
- What is the approximate cut-off frequency of the filter in rad/sec?
- Give an op amp circuit using one op amp (with two resistors and one capacitor) that will produce this frequency response. The capacitor is restricted to be $0.1 \mu\text{F}$. Give the op amp circuit and the values of R_1 and R_2 . Identify the output and input of your op amp circuit.
- Give the transfer function of your filter.

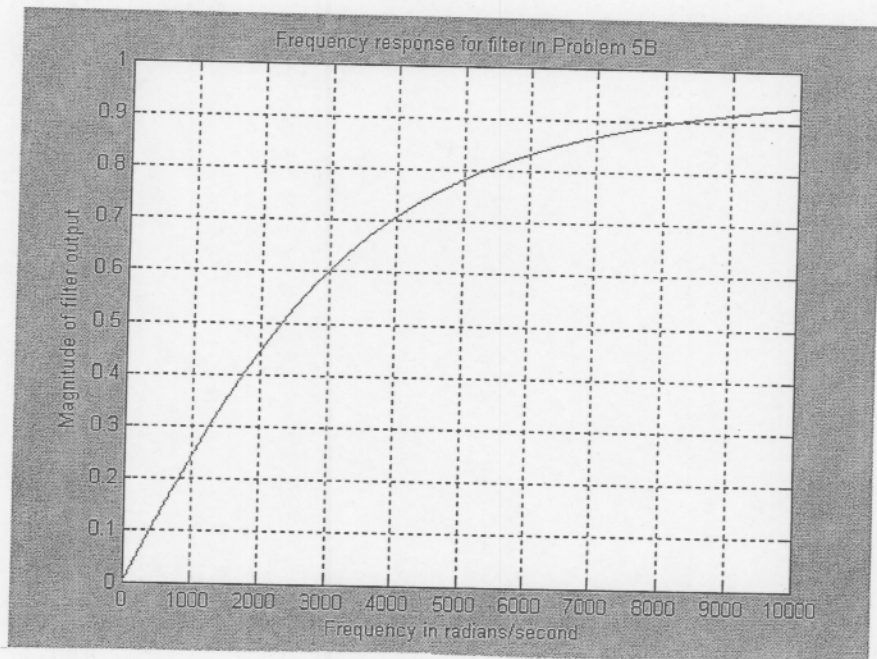

(a) high pass

(b) 4000 rad/sec.

(c)

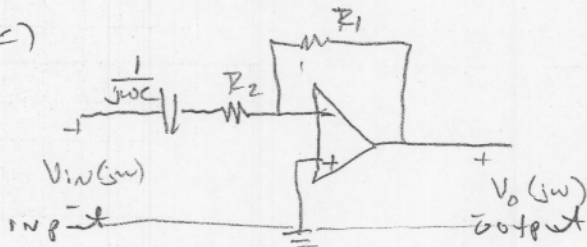

$$Z_{in} = R_2 + \frac{1}{j\omega C}$$

$$= \frac{1 + j\omega R_2 C}{j\omega C}$$

$$\frac{V_o(j\omega)}{V_{in}(j\omega)} = - \frac{j\omega R_1 C}{1 + j\omega R_2 C}$$

$$\omega_{co} = 4000 = \frac{1}{R_2 C}$$

$$R_2 = \frac{1}{4 \times 10^3 \times 0.1 \times 10^{-6}} = 2.5 \text{ k}\Omega = R_1$$

$$R_1 = R_2 = 2.5 \text{ k}\Omega$$