

Course Content

- Magnetically Coupled Circuits (Ch 13)
- Sinusoidal Steady-State Analysis (Ch 10)
- AC Circuit Power Analysis (Ch 11)
- Circuit Analysis in the s-Domain (Ch 14)
- Frequency Response (Ch 15)
- Fourier Circuit Analysis (Ch 17)
- Polyphase Circuits (Ch 12)
- Two-Port Networks (Ch 16)

Transform Domains

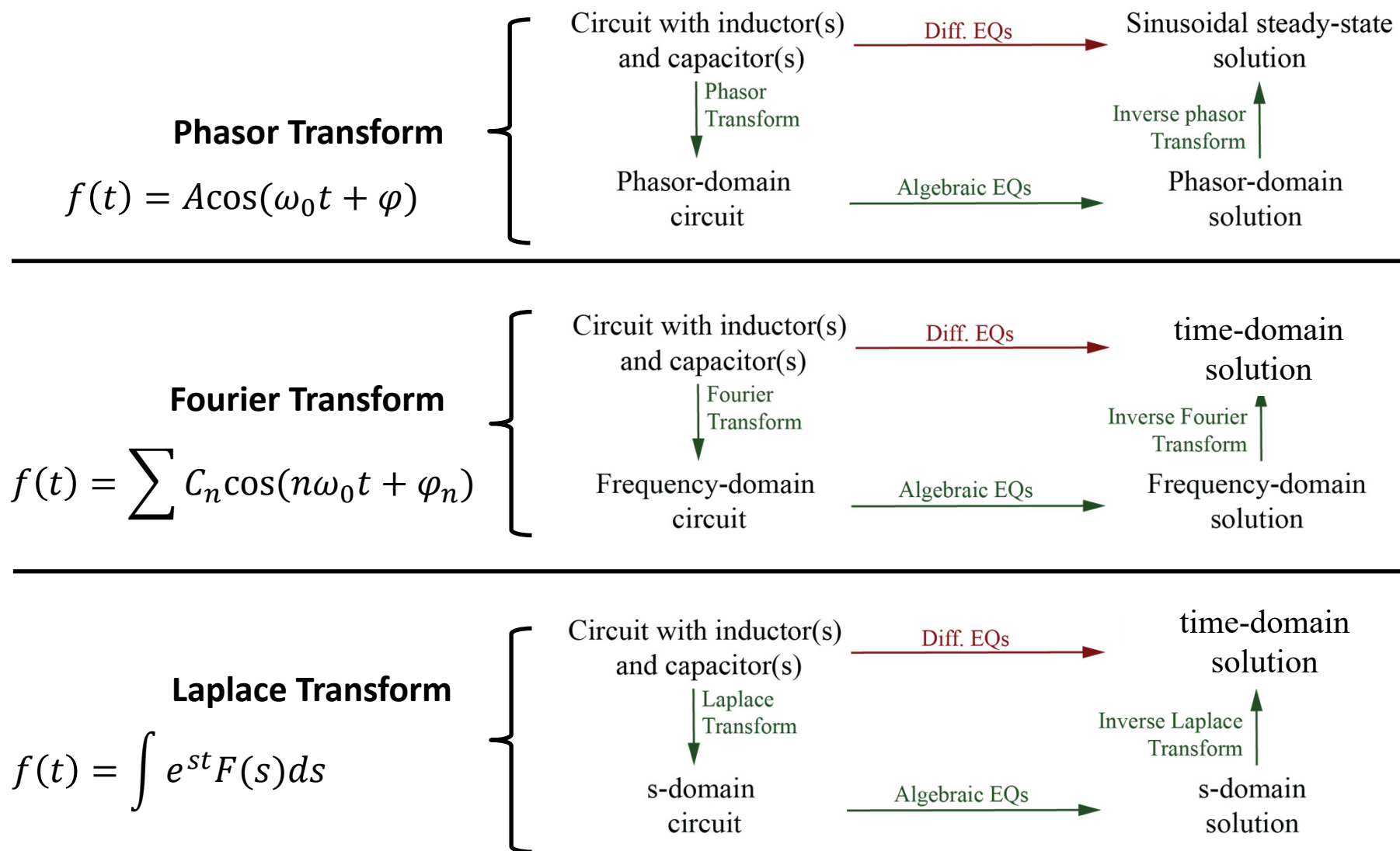

Ch 13 – Magnetically Coupled Circuits

Coupled Inductors

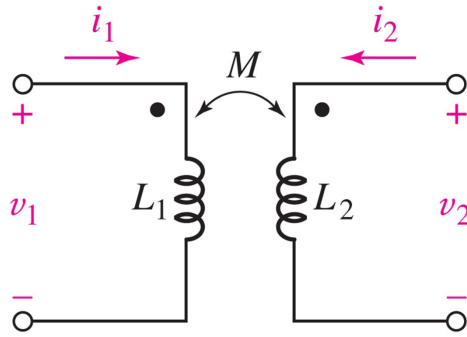

Defining Equations

$$v_1(t) = L_1 \frac{di_1}{dt} + M \frac{di_2}{dt}$$

$$v_2(t) = M \frac{di_1}{dt} + L_2 \frac{di_2}{dt}$$

Dot convention

- Current into the dot on one terminal produces a positive open circuit voltage w.r.t. the dot on the other

Coupling Coefficient

$$k = \frac{M}{\sqrt{L_p L_s}}$$

Recall

- Equivalent circuits

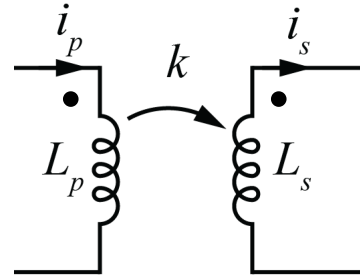

Ideal Transformer

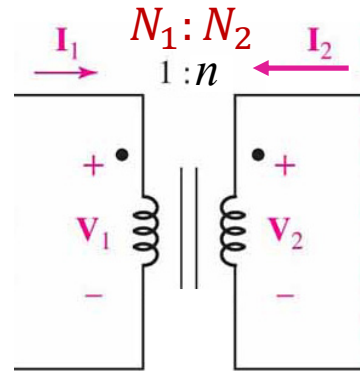

Defining Equations

$$\frac{V_1}{N_1} = \frac{V_2}{N_2} = \dots$$

$$0 = N_1 I_1 + N_2 I_2 + \dots$$

Coupled inductors with:

- no energy storage ($L \rightarrow \infty$)
- Perfect coupling ($k=1$)

Recall

- Z/V/I reflection

Ch 10 – Sinusoidal Steady State

Time Domain

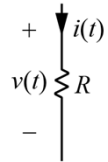

$$v(t) = i(t)R$$

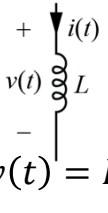

$$v(t) = L \frac{di}{dt}$$

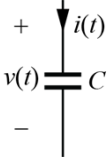

$$i(t) = C \frac{dv}{dt}$$

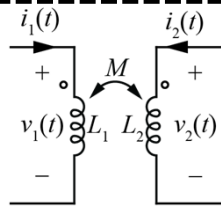

$$v_1(t) = L_1 \frac{di_1}{dt} + M \frac{di_2}{dt}$$

$$v_2(t) = M \frac{di_1}{dt} + L_2 \frac{di_2}{dt}$$

Phasor Domain

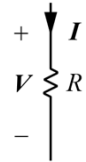

$$V = IR$$

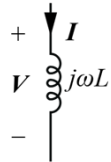

$$V = j\omega LI$$

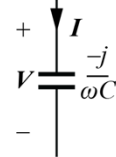

$$V = \frac{-j}{\omega C} I$$

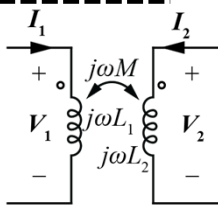

$$V_1 = j\omega L_1 I_1 + j\omega M I_2$$

$$V_2 = j\omega M I_1 + j\omega L_2 I_2$$

Phasor Notation

$$A \cos(\omega t + \varphi) \Leftrightarrow A \angle \varphi$$

$$= \text{Re}\{A e^{j(\omega t + \varphi)}\}$$

$$= \text{Re}\{A \cos(\omega t + \varphi) + j A \sin(\omega t + \varphi)\}$$

Impedance and Admittance

$$Z = R + jX$$

Impedance

Resistance

Reactance

$$Y = \frac{1}{Z} = G + jB$$

Admittance

Conductance

Susceptance

Circuit Analysis

- Real circuits always have all real signals in the time domain
- All 201 analysis techniques apply
- Gives only forced/steady-state/particular response, for single sinusoidal source
- Phasor superposition

Ch 11 – AC Power Analysis

Average (DC) Power: $P = \int_{-\infty}^{\infty} p(t)dt$ For periodic signals: $P = \int_{t_0}^{t_0+T} p(t)dt$

Average power in a resistor: $P_R = \left[\underbrace{\int i(t)^2 dt}_{I_{rms} = I_{eff}} \right]^2 R$ For sinusoids: $I_{rms} = \frac{I_A}{\sqrt{2}}$

Sinusoidal Power

$$p(t) = [V_A \cos(\omega t + \varphi_V)][I_A \cos(\omega t + \varphi_I)]$$

$$= \underbrace{\frac{V_A I_A}{2} \cos(2\omega t + \varphi_V + \varphi_I)}_{\text{Double-frequency}} + \underbrace{\frac{V_A I_A}{2} \cos(\varphi_V - \varphi_I)}_{\text{DC = average}} \qquad \frac{V_A I_A}{2} = V_{rms} I_{rms}$$

Complex Power

$$S = \frac{VI^*}{2} = V_{rms} I_{rms}$$

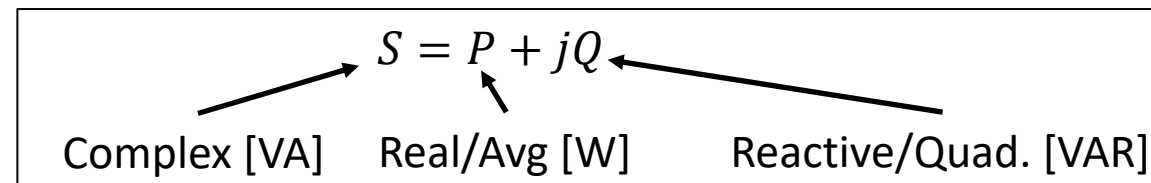

Apparent Power: $|S| = \frac{V_A I_A}{2} = V_{rms} I_{rms}$ Power Factor: $PF = \frac{P}{|S|}$ (leading/lagging)

Impedance match for max power transfer: $Z_L = Z_{th}^*$

Ch 14 – Laplace Transform

Unilateral Laplace Transform: $F(s) = \mathcal{L}\{f(t)\} = \int_{0^-}^{\infty} e^{-st} f(t) dt$

Inverse Laplace Transform: $f(t) = \mathcal{L}^{-1}\{F(s)\} = \frac{1}{2\pi j}$

, σ_0 in ROC
(to the right of all
poles in complex
plane)

Complex frequency = Laplace variable = $s = \sigma + j\omega$

Laplace transform is a **linear transformation**. Other properties and transforms in tables

Inverse Transforms: *Long Division* → *Factor* → *PFE* → *Tables*

PFE Special cases:

Repeated: $\frac{N(s)}{(s+5)^2} = \frac{k_1}{s+5} + \frac{k_2}{(s+5)^2}$ (Differentiation or coefficient matching)

Complex: $\frac{N(s)}{s^2+4} = \frac{k_1 s + k_2}{s^2+4} = \frac{k_1}{s-j2} + \frac{k_1^*}{s+j2}$

Ch 14 – Laplace Circuit Analysis

Poles and Zeros:

$$F(s) = \frac{N(s)}{D(s)}$$

Zeros: roots of $N(s)$

Poles: roots of $D(s)$

Circuit Transformation:

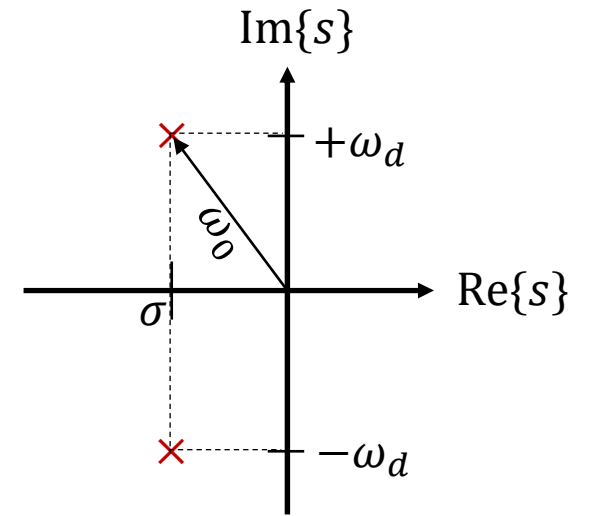
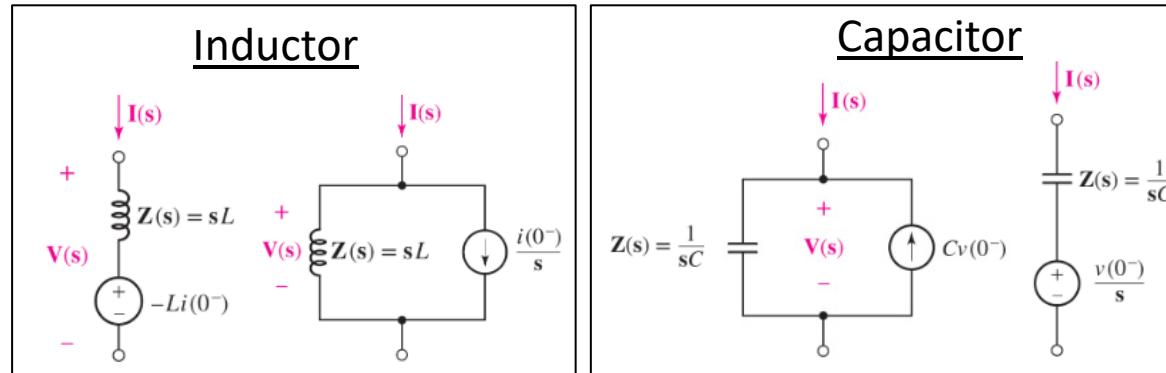

Convolution:

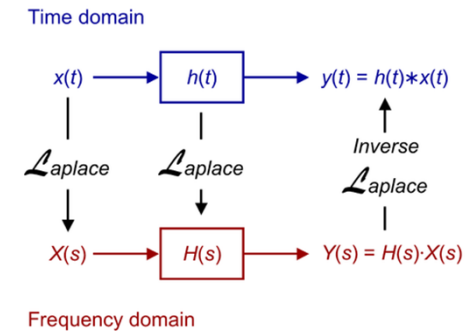

$$v_o(t) = v_i(t) * h(t) = \int_{-\infty}^{\infty} v_i(t - \tau)h(\tau)d\tau$$

Transfer Functions:

$$H(s) = \frac{V_o(s)}{V_i(s)}$$

Poles of $H(s)$ define “form” of terms in natural response of the circuit

Poles of $V_i(s)$ define “form” of terms in forced response of the circuit

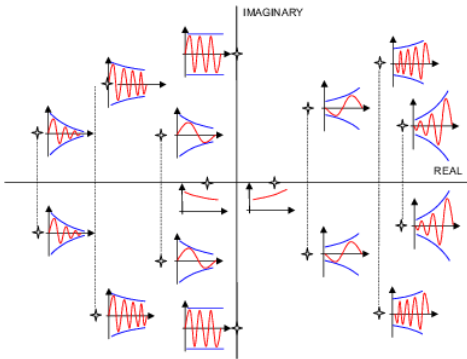

Ch 15 – Frequency Response

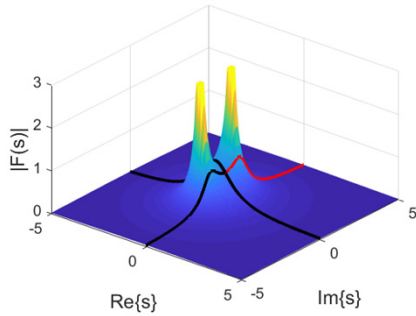

Frequency Response: $H(s \rightarrow j\omega)$

- Circuit response to sinusoidal inputs
- Valid if all poles in LHP

Bode plot: mag-phase plots on log-log axes

- $\|H(j\omega)\|_{dB} = 20 \log(|H(j\omega)|)$
- $\angle H(j\omega)$

Templates and Approximations:

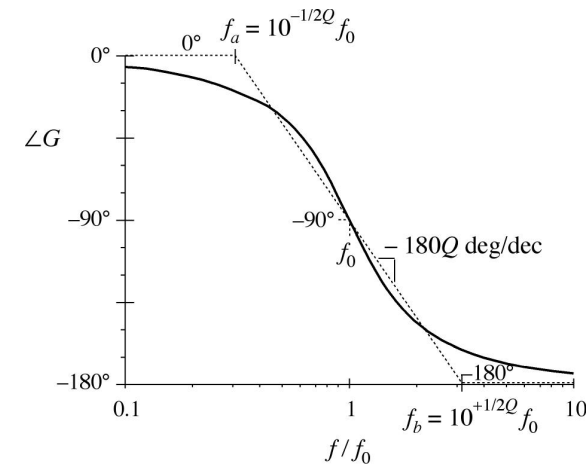
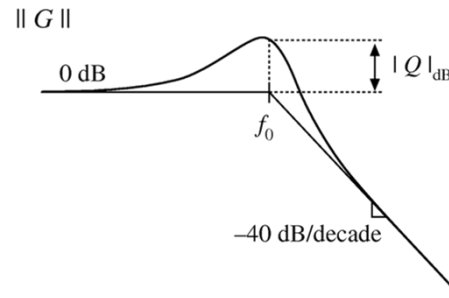
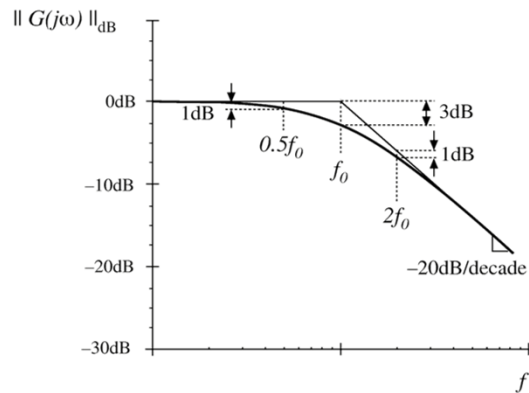

Filter Design

- Bandwidth, graphical analysis, Chebyshev and Butterworth, Sallen-Key Amplifier
- Resonant circuits

Ch 17 – Fourier Series and Transform



https://en.wikipedia.org/wiki/Fourier_transform

Fourier Series:

For periodic $f(t)$ with period $T_0 = \frac{2\pi}{\omega_0}$

$$f(t) = a_0 + \sum_{k=1}^{\infty} a_k \cos(k\omega_0 t) + b_k \sin(k\omega_0 t)$$

$$a_k = \frac{2}{T_0} \int_{t_0}^{t_0+T_0} f(t) \cos(k\omega_0 t) dt$$

$$b_k = \frac{2}{T_0} \int_{t_0}^{t_0+T_0} f(t) \sin(k\omega_0 t) dt$$

Fourier Transform:

For periodic or non-periodic $f(t)$

$$F(\omega) = \mathcal{F}\{f(t)\} = \int_{-\infty}^{\infty} e^{-j\omega t} f(t) dt$$

$$f(t) = \mathcal{F}^{-1}\{F(\omega)\} = \frac{1}{2\pi} \int_{-\infty}^{\infty} e^{j\omega t} F(\omega) d\omega$$

- Frequency content of a signal
- Gives mag/phase of sinusoids that add up to original signal

FUTURE TOPICS

Power Systems

- ECE 325 -- Electric Energy System Components

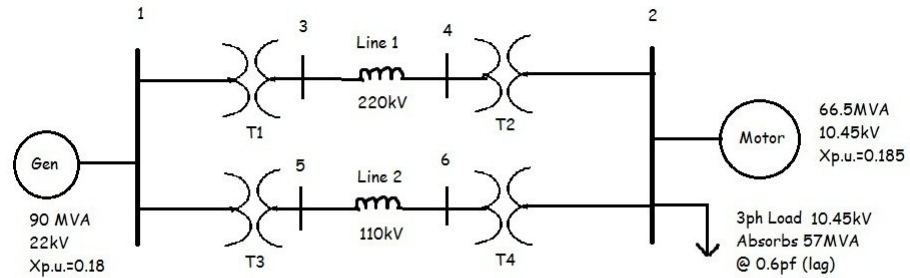

T1: 50MVA 22/220kV $X_{p.u.}=0.10$
 T2: 40MVA 220/11kV $X_{p.u.}=0.06$
 T3: 40MVA 22/110kV $X_{p.u.}=0.064$
 T4: 40MVA 110/11kV $X_{p.u.}=0.08$
 Line 1: 48.4Ohms (total)
 Line 2: 65.43Ohms (total)

PEguru.com

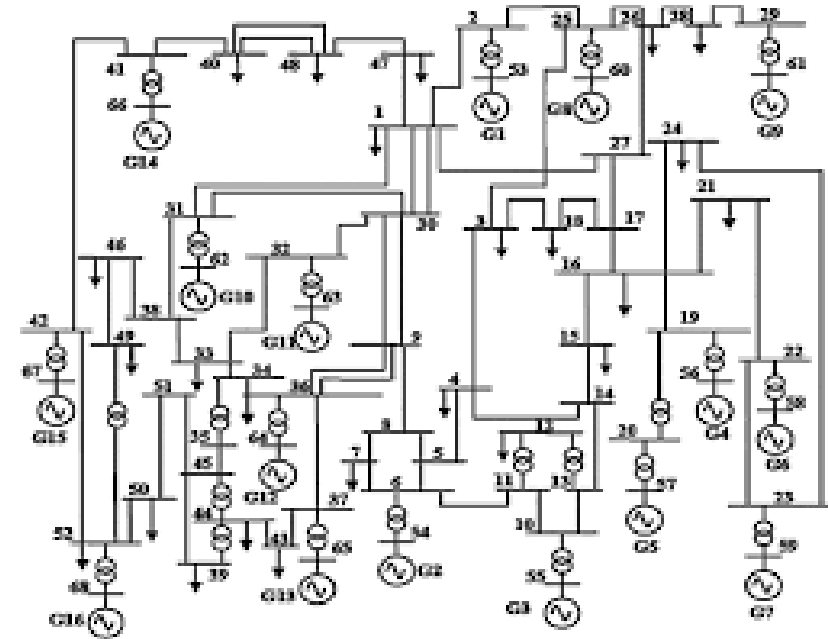

Nonlinear Circuits

- ECE 335 & 336 – Electronic Devices

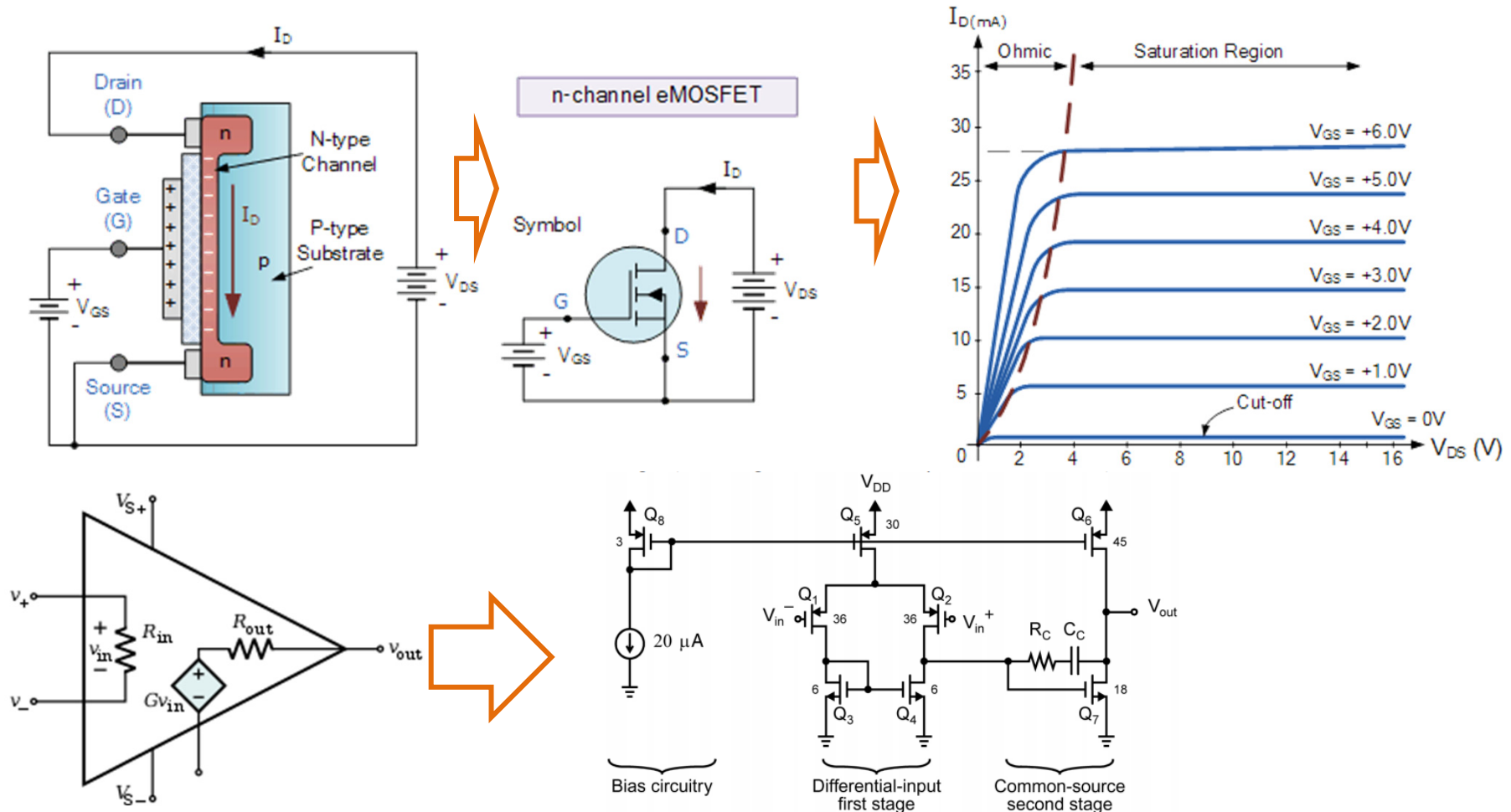

Closed-Loop Control

- ECE 316 – Signals and Systems

Classic Control

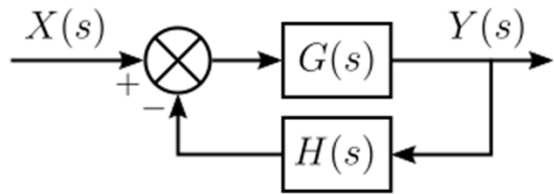

Root Locus: How poles and zeros move as you change feedback

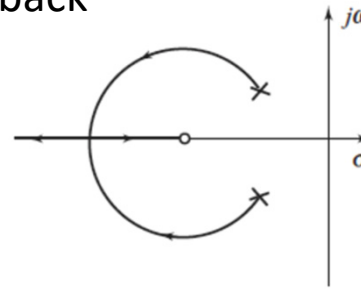

Nyquist Plots: Frequency response in the complex plane

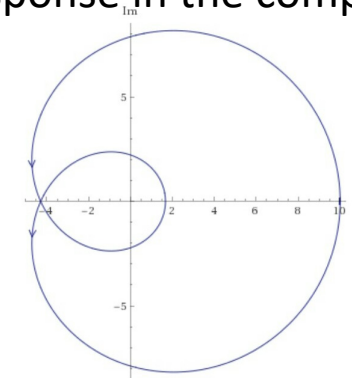

Modern Control

$$\begin{aligned}\dot{\mathbf{x}}(t) &= \mathbf{A}(t)\mathbf{x}(t) + \mathbf{B}(t)\mathbf{u}(t) \\ \mathbf{y}(t) &= \mathbf{C}(t)\mathbf{x}(t) + \mathbf{D}(t)\mathbf{u}(t)\end{aligned}$$

$$H(s) = \mathbf{C}(s\mathbf{I} - \mathbf{A})^{-1}\mathbf{B} + \mathbf{D}$$

Digital / Discrete Time Signals

- ECE 315 – Signals and Systems

Cont. time $\sum_n A_n \frac{d^n}{dt^n} v_o(t) = \sum_m B_m \frac{d^m}{dt^m} v_i(t) \xrightarrow{\mathcal{L}} \sum_n A_n s^n V_o(s) = \sum_m B_m s^m V_i(s)$

Discrete time $\sum_n A_n y[k - n] = \sum_m B_m u[k - m] \xrightarrow{\mathcal{Z}} \sum_n A_n z^{-n} Y(z) = \sum_m B_m z^{-m} U(z)$

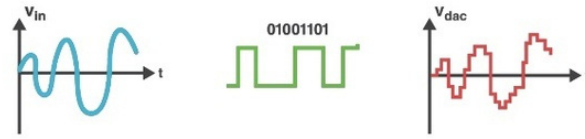

Sampling and aliasing:

