Lecture 4: Steady-State Averaged Modeling

ECE 481: Power Electronics
Prof. Daniel Costinett
Department of Electrical Engineering and Computer Science
University of Tennessee Knoxville
Fall 2013

Ideal Transformer Model

Simplifying Circuits With Ideal XF

Simplifying Circuits With Ideal XF

Simplifying Circuits With Ideal XF

3.1. The dc transformer model

Basic equations of an ideal dc-dc converter:

$$P_{in} = P_{out} \quad (\eta = 100\%)$$
$$V_g I_g = V I$$

$$V = M(D) V_g \quad (\text{ideal conversion ratio})$$
$$I_g = M(D) I$$

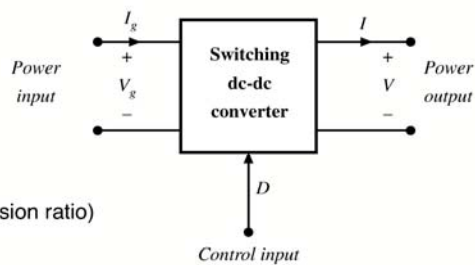

These equations are valid in steady-state. During transients, energy storage within filter elements may cause $P_{in} \neq P_{out}$

Equivalent circuits corresponding to ideal dc-dc converter equations

$$P_{in} = P_{out} \quad V_g I_g = V I \quad V = M(D) V_g \quad I_g = M(D) I$$

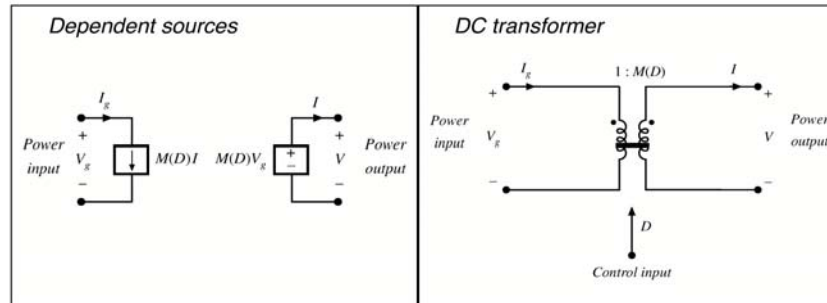

The DC transformer model

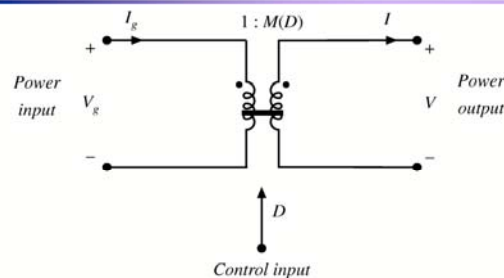

Models basic properties of ideal dc-dc converter:

- conversion of dc voltages and currents, ideally with 100% efficiency
- conversion ratio M controllable via duty cycle

- Solid line denotes ideal transformer model, capable of passing dc voltages and currents
- Time-invariant model (no switching) which can be solved to find dc components of converter waveforms

Example: use of the DC transformer model

1. Original system

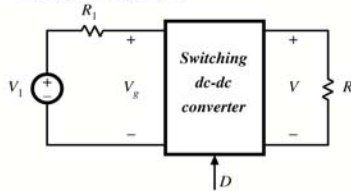

2. Insert dc transformer model

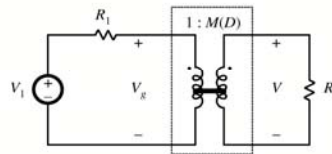

3. Push source through transformer

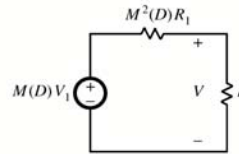

4. Solve circuit

$$V = M(D) V_1 \frac{R}{R + M^2(D) R_1}$$

3.2. Inclusion of inductor copper loss

Dc transformer model can be extended, to include converter nonidealities.

Example: inductor copper loss (resistance of winding):



Insert this inductor model into boost converter circuit:

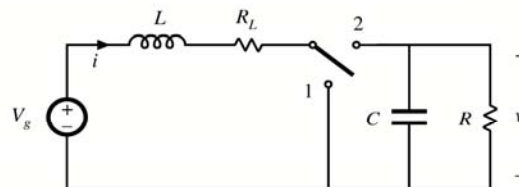

Analysis of nonideal boost converter

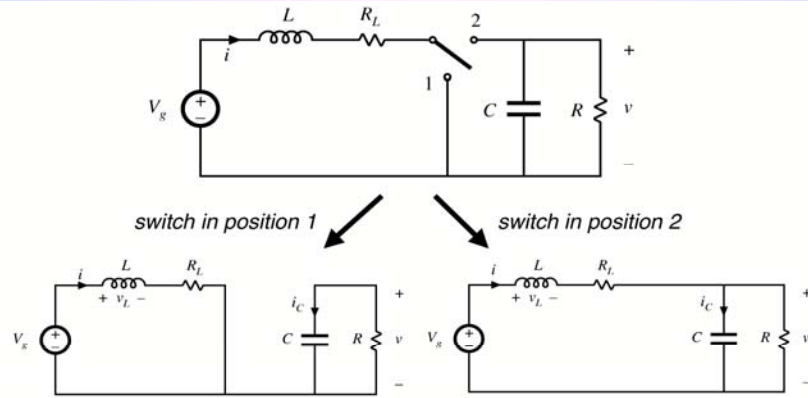

Nonideal Boost Converter

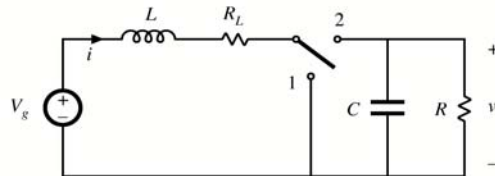

Circuit equations, switch in position 1

Inductor current and capacitor voltage:

$$v_L(t) = V_g - i(t) R_L$$

$$i_C(t) = -v(t) / R$$

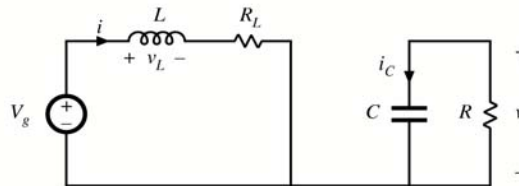

Small ripple approximation:

$$v_L(t) = V_g - I R_L$$

$$i_C(t) = -V / R$$

Circuit equations, switch in position 2

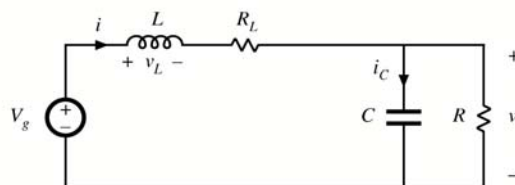

$$v_L(t) = V_g - i(t) R_L - v(t) \approx V_g - I R_L - V$$

$$i_C(t) = i(t) - v(t) / R \approx I - V / R$$

Inductor voltage and capacitor current waveforms

Average inductor voltage:

$$\begin{aligned} \langle v_L(t) \rangle &= \frac{1}{T_s} \int_0^{T_s} v_L(t) dt \\ &= D(V_g - I R_L) + D'(V_g - I R_L - V) \end{aligned}$$

Inductor volt-second balance:

$$0 = V_g - I R_L - D'V$$

Average capacitor current:

$$\langle i_c(t) \rangle = D(-V/R) + D'(I - V/R)$$

Capacitor charge balance:

$$0 = D'I - V/R$$

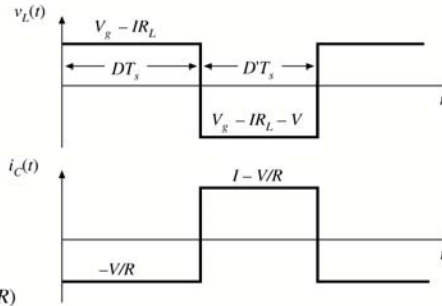

Solution for output voltage

We now have two equations and two unknowns:

$$0 = V_g - I R_L - D'V$$

$$0 = D'I - V/R$$

Eliminate I and solve for V :

$$\frac{V}{V_g} = \frac{1}{D'} \frac{1}{(1 + R_L / D^2 R)}$$

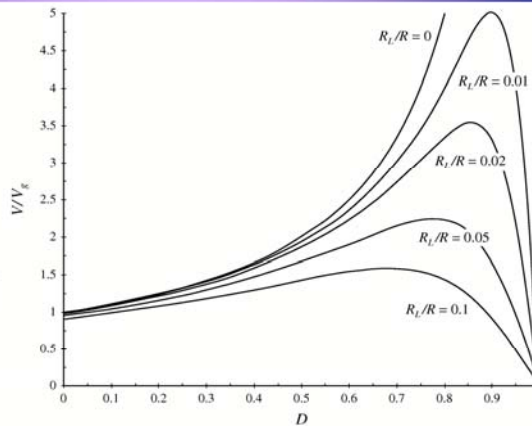

3.3. Construction of equivalent circuit model

Results of previous section (derived via inductor volt-sec balance and capacitor charge balance):

$$\begin{aligned}\langle v_L \rangle &= 0 = V_g - I R_L - D'V \\ \langle i_C \rangle &= 0 = D'I - V/R\end{aligned}$$

View these as loop and node equations of the equivalent circuit.
Reconstruct an equivalent circuit satisfying these equations

Inductor voltage equation

$$\langle v_L \rangle = 0 = V_g - I R_L - D'V$$

- Derived via Kirchhoff's voltage law, to find the inductor voltage during each subinterval
- Average inductor voltage then set to zero
- This is a loop equation: the dc components of voltage around a loop containing the inductor sum to zero

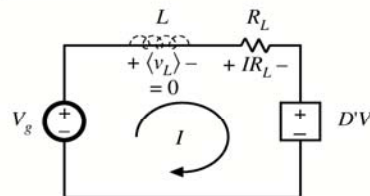

- IR_L term: voltage across resistor of value R_L having current I
- $D'V$ term: for now, leave as dependent source

Capacitor current equation

$$\langle i_c \rangle = 0 = D'I - V/R$$

- Derived via Kirchoff's current law, to find the capacitor current during each subinterval
- Average capacitor current then set to zero
- This is a node equation: the dc components of current flowing into a node connected to the capacitor sum to zero

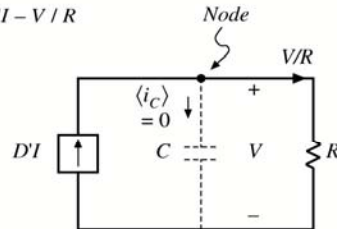

- V/R term: current through load resistor of value R having voltage V
- $D'I$ term: for now, leave as dependent source

Complete equivalent circuit

The two circuits, drawn together:

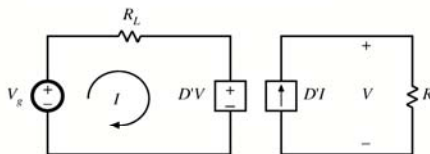

The dependent sources are equivalent to a $D':1$ transformer:

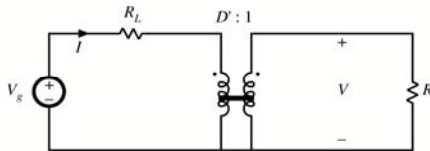

Dependent sources and transformers

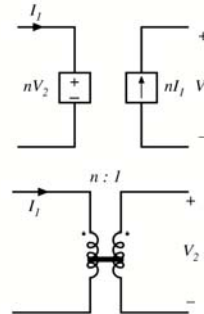

- sources have same coefficient
- reciprocal voltage/current dependence

Solution of equivalent circuit

Converter equivalent circuit

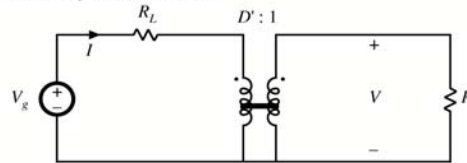

Refer all elements to transformer secondary:

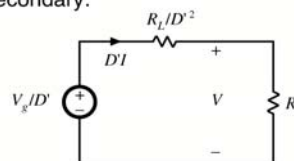

Solution for output voltage using voltage divider formula:

$$V = \frac{V_g}{D'} \frac{R}{R + \frac{R_L}{D'^2}} = \frac{V_g}{D'} \frac{1}{1 + \frac{R_L}{D'^2 R}}$$

Solution for input (inductor) current

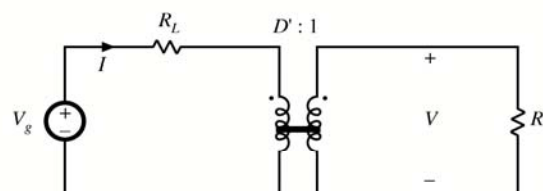

$$I = \frac{V_g}{D'^2 R + R_L} = \frac{V_g}{D'^2} \frac{1}{1 + \frac{R_L}{D'^2 R}}$$

Solution for converter efficiency

$$P_{in} = (V_g)(I)$$

$$P_{out} = (V)(D'I)$$

$$\eta = \frac{P_{out}}{P_{in}} = \frac{(V)(D'I)}{(V_g)(I)} = \frac{V}{V_g} D'$$

$$\eta = \frac{1}{1 + \frac{R_L}{D'^2 R}}$$

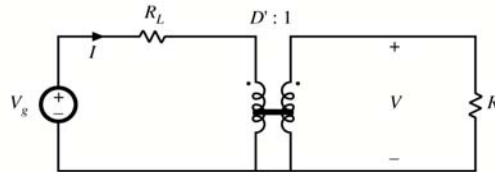

Efficiency, for various values of R_L

$$\eta = \frac{1}{1 + \frac{R_L}{D'^2 R}}$$

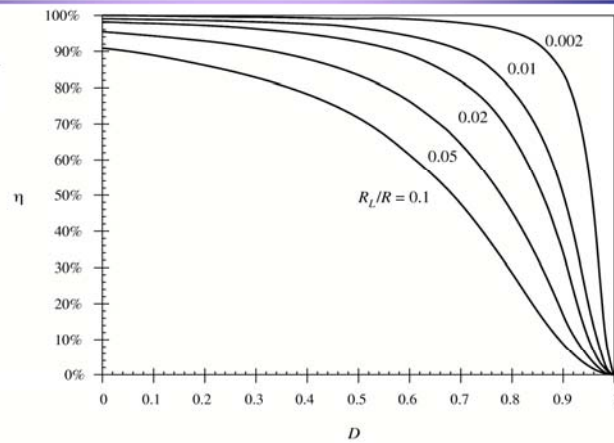

3.4. How to obtain the input port of the model

Buck converter example — use procedure of previous section to derive equivalent circuit

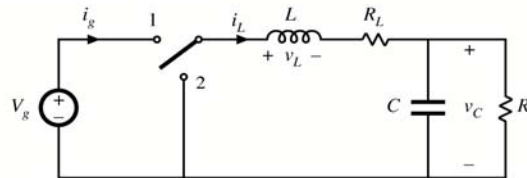

Average inductor voltage and capacitor current:

$$\langle v_L \rangle = 0 = DV_g - I_L R_L - V_C \quad \langle i_C \rangle = 0 = I_L - V_C / R$$

Construct equivalent circuit as usual

$$\langle v_L \rangle = 0 = DV_g - I_L R_L - V_C \quad \langle i_C \rangle = 0 = I_L - V_C / R$$

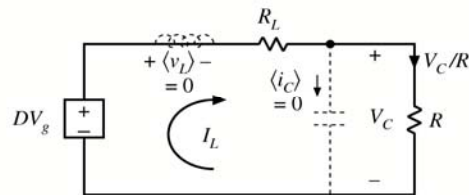

What happened to the transformer?

- Need another equation

Modeling the converter input port

Input current waveform $i_g(t)$:

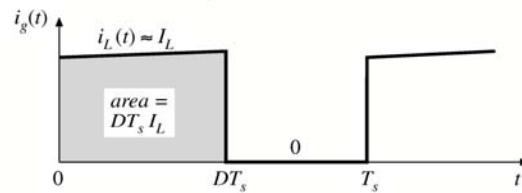

Dc component (average value) of $i_g(t)$ is

$$I_g = \frac{1}{T_s} \int_0^{T_s} i_g(t) dt = DI_L$$

Input port equivalent circuit

$$I_g = \frac{1}{T_s} \int_0^{T_s} i_g(t) dt = DI_L$$

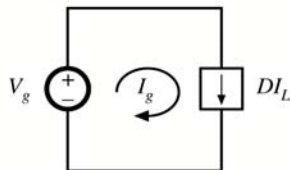

Complete equivalent circuit, buck converter

Input and output port equivalent circuits, drawn together:

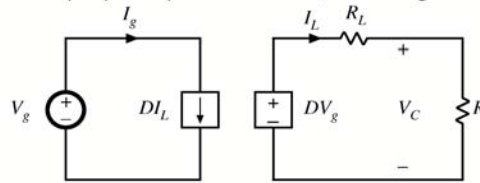

Replace dependent sources with equivalent dc transformer:

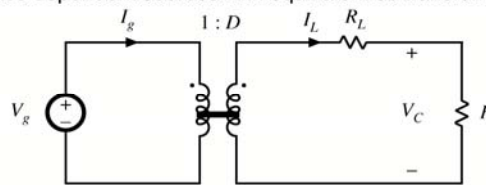

3.5. Example: inclusion of semiconductor conduction losses in the boost converter model

Boost converter example

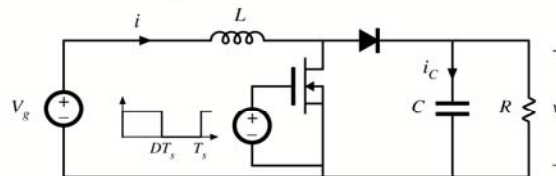

Models of on-state semiconductor devices:

MOSFET: on-resistance R_{on}

Diode: constant forward voltage V_D plus on-resistance R_D

Insert these models into subinterval circuits

Modeling of component conduction losses

Boost converter example: circuits during subintervals 1 and 2

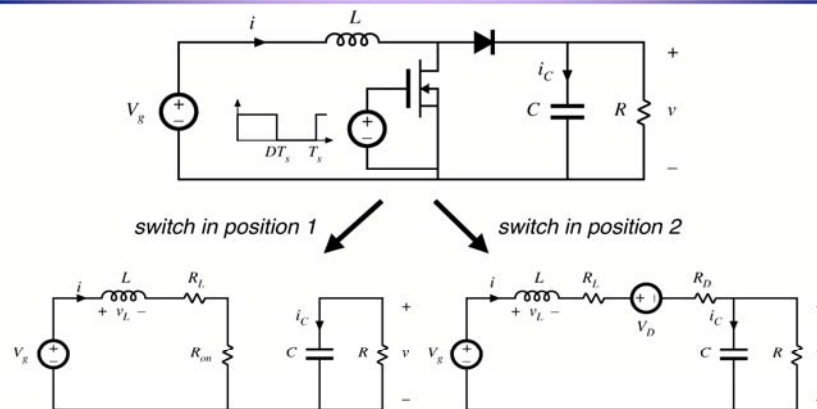

Average inductor voltage and capacitor current

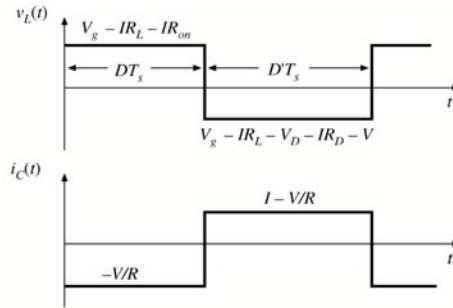

$$\langle v_L \rangle = D(V_g - IR_L - IR_{on}) + D'(V_g - IR_L - V_D - IR_D - V) = 0$$

$$\langle i_C \rangle = D(-V/R) + D'(I - V/R) = 0$$

Construction of equivalent circuits

$$V_g - IR_L - IDR_{on} - D'V_D - ID'R_D - D'V = 0$$

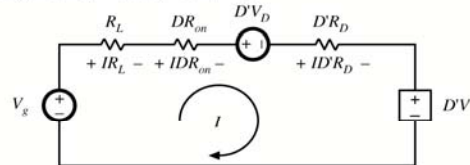

$$D'I - V/R = 0$$

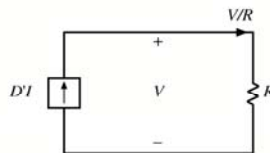

Complete equivalent circuit

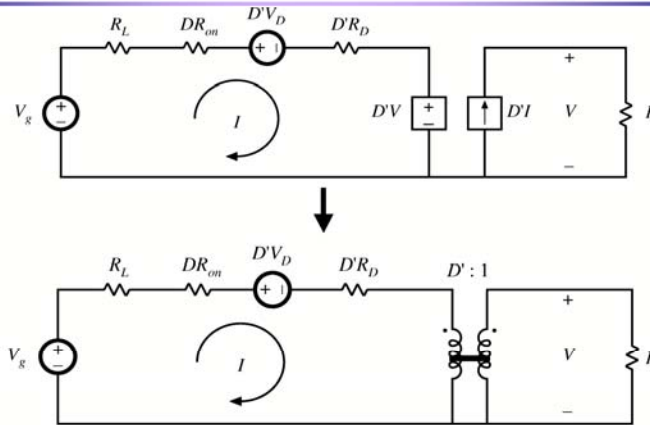

Solution for output voltage

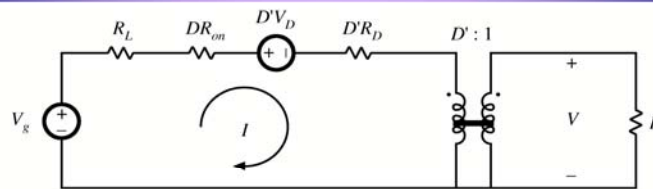

$$V = \left(\frac{1}{D'}\right) (V_g - D'V_D) \left(\frac{D'^2 R}{D'^2 R + R_L + DR_{on} + D'R_D} \right)$$

$$\frac{V}{V_g} = \left(\frac{1}{D'}\right) \left(1 - \frac{D'V_D}{V_g} \right) \left(\frac{1}{1 + \frac{R_L + DR_{on} + D'R_D}{D'^2 R}} \right)$$

Solution for converter efficiency

$$P_{in} = (V_g) (I)$$

$$P_{out} = (V) (D'I)$$

$$\eta = D' \frac{V}{V_g} = \frac{\left(1 - \frac{D'V_D}{V_g}\right)}{\left(1 + \frac{R_L + DR_{on} + D'R_D}{D'^2R}\right)}$$

Conditions for high efficiency:

$$V_g/D' \gg V_D$$

$$D'^2R \gg R_L + DR_{on} + D'R_D$$

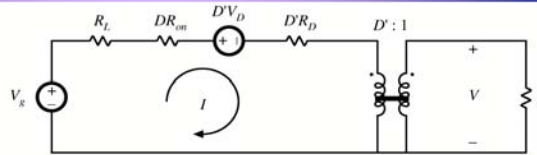

Accuracy of the averaged equivalent circuit in prediction of losses

- Model uses average currents and voltages
- To correctly predict power loss in a resistor, use rms values
- Result is the same, provided ripple is small

MOSFET current waveforms, for various ripple magnitudes:

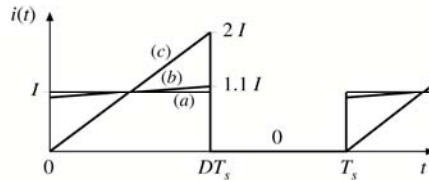

Inductor current ripple	MOSFET rms current	Average power loss in R_{on}
(a) $\Delta i = 0$	$I \sqrt{D}$	$D \hat{I}^2 R_{on}$
(b) $\Delta i = 0.1 I$	$(1.00167) I \sqrt{D}$	$(1.0033) D \hat{I}^2 R_{on}$
(c) $\Delta i = I$	$(1.155) I \sqrt{D}$	$(1.3333) D \hat{I}^2 R_{on}$

Summary of chapter 3

1. The dc transformer model represents the primary functions of any dc-dc converter: transformation of dc voltage and current levels, ideally with 100% efficiency, and control of the conversion ratio M via the duty cycle D . This model can be easily manipulated and solved using familiar techniques of conventional circuit analysis.
2. The model can be refined to account for loss elements such as inductor winding resistance and semiconductor on-resistances and forward voltage drops. The refined model predicts the voltages, currents, and efficiency of practical nonideal converters.
3. In general, the dc equivalent circuit for a converter can be derived from the inductor volt-second balance and capacitor charge balance equations. Equivalent circuits are constructed whose loop and node equations coincide with the volt-second and charge balance equations. In converters having a pulsating input current, an additional equation is needed to model the converter input port; this equation may be obtained by averaging the converter input current.