

LTSpice Simulation

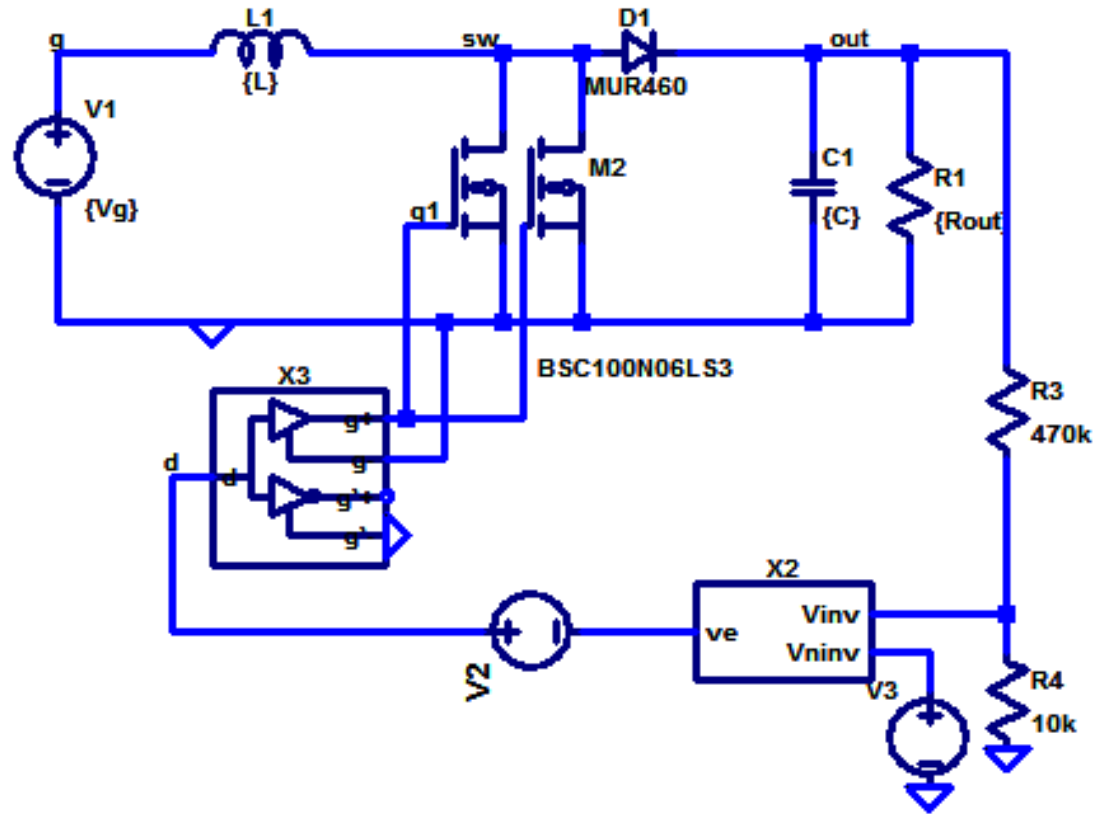

L	C_{out}	f_s	η (Sim)
22uH	22uF	200k	93.9%

LTSpice Simulation

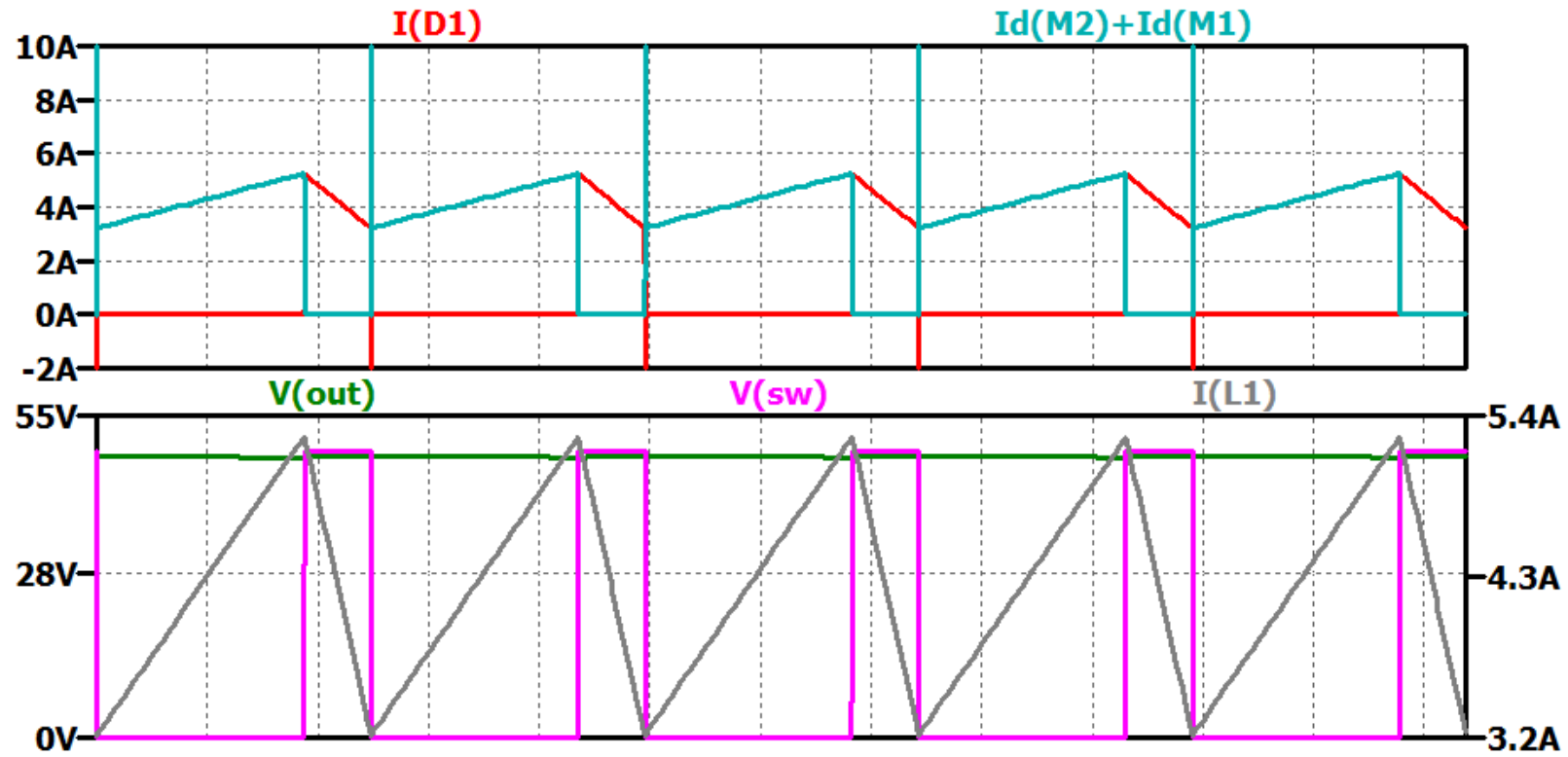

Switching Transition

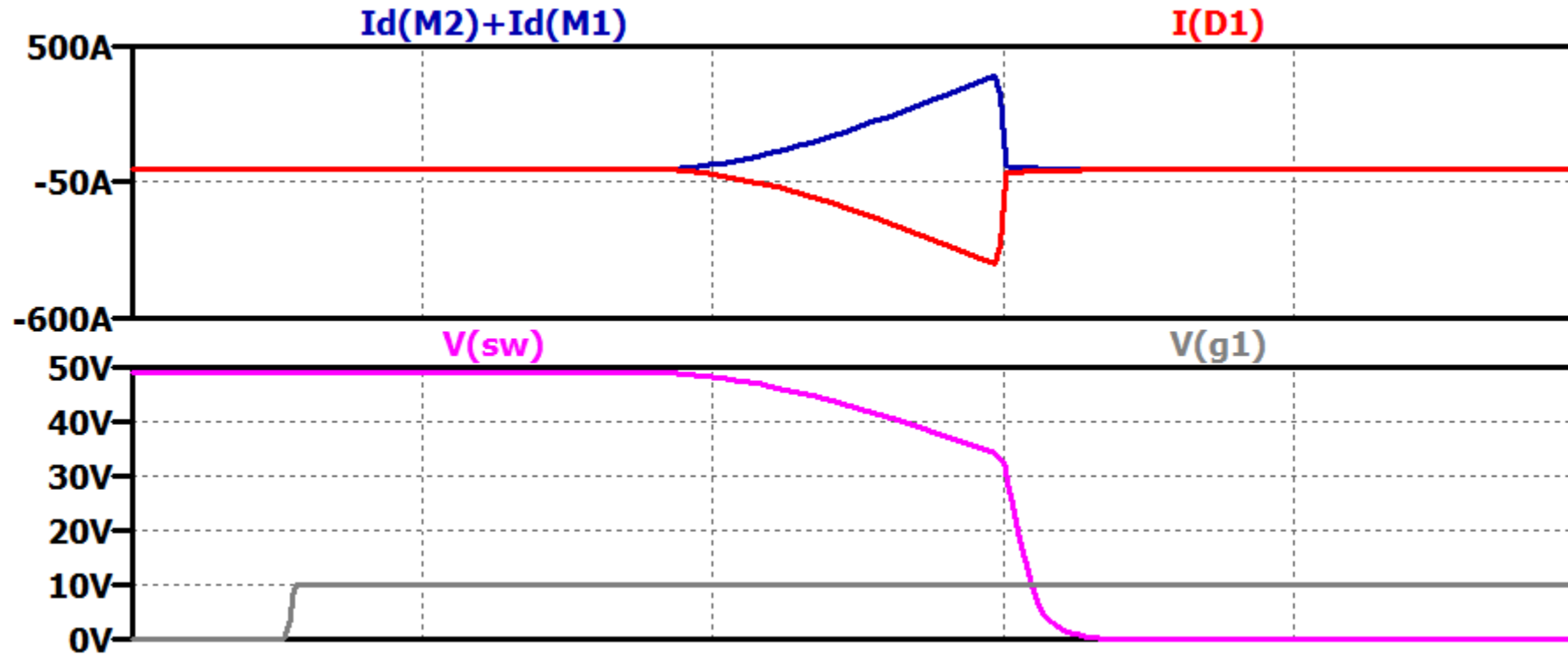

Diode Switching Waveforms

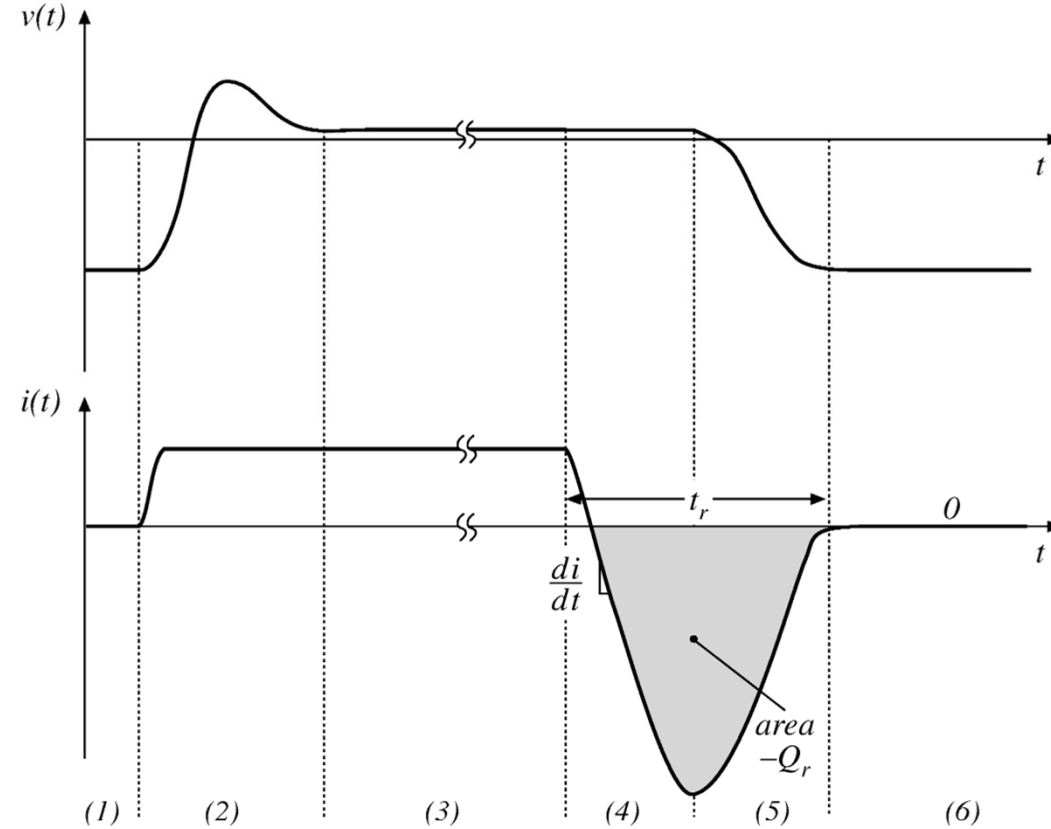

Power Diodes

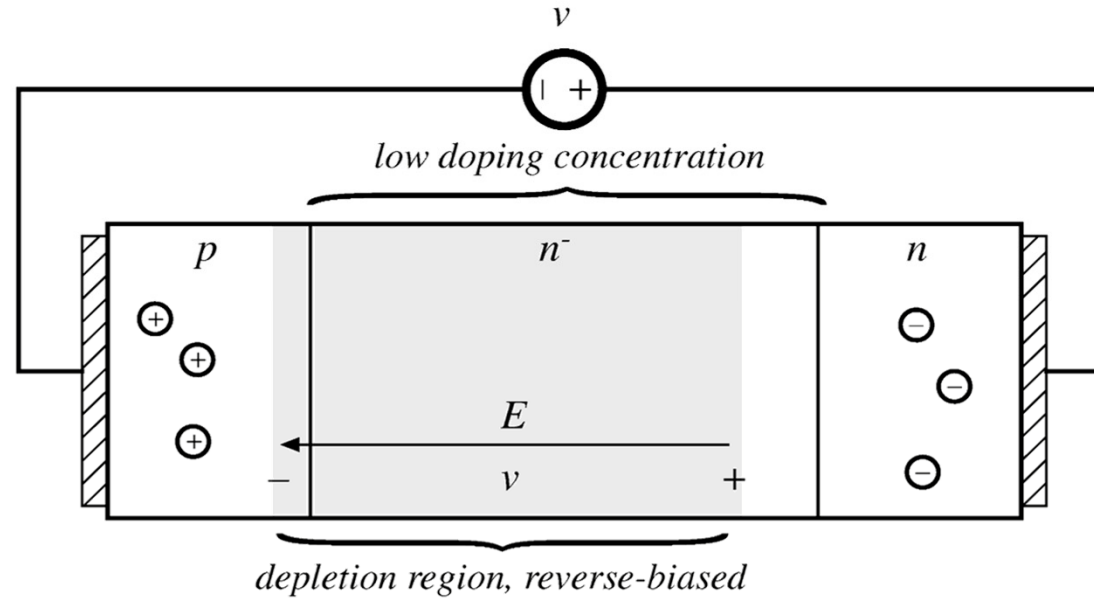

Forward Biased Diode

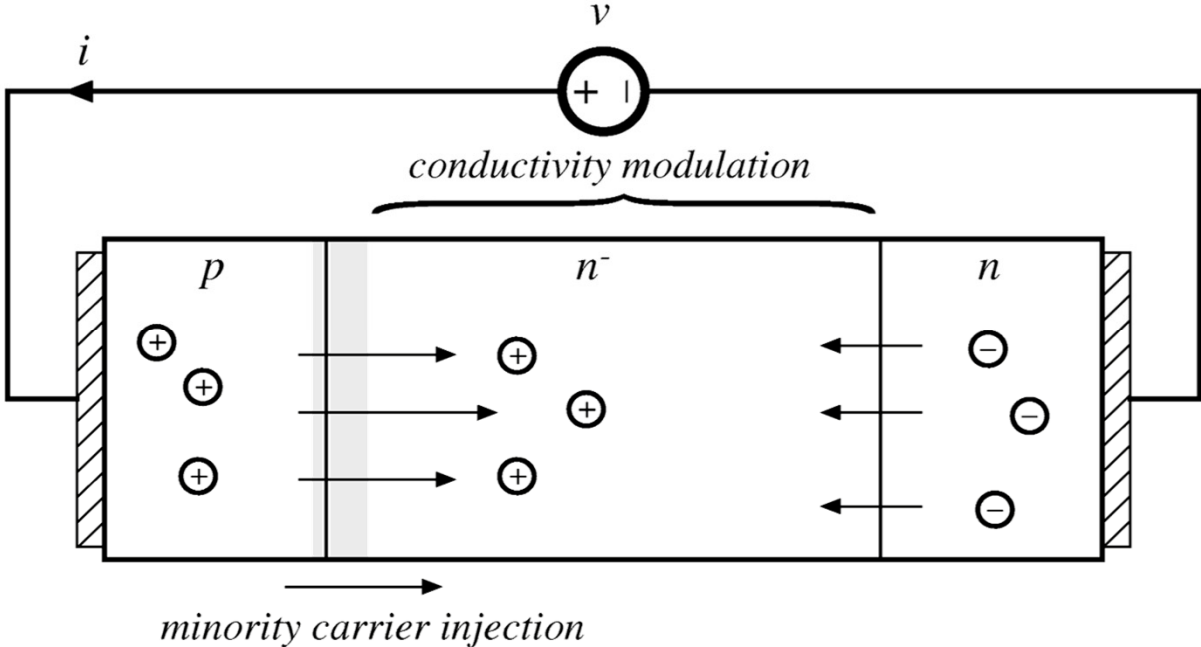

Diode Stored Charge

The diode equation:

$$q(t) = Q_0(e^{\lambda v(t)} - 1)$$

Charge control equation:

$$\frac{dq(t)}{dt} = i(t) - \frac{q(t)}{\tau_L}$$

With:

$\lambda = 1/(26 \text{ mV})$ at 300 K

$\tau_L =$ minority carrier lifetime

(above equations don't include current that charges depletion region capacitance)

Fundamentals of Power Electronics

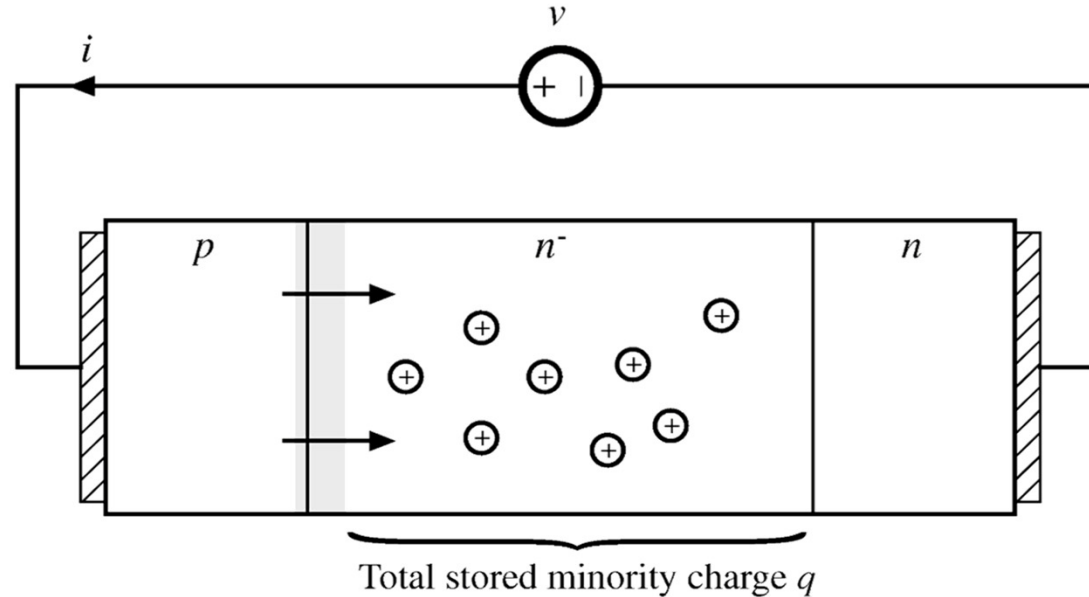

In equilibrium: $dq/dt = 0$, and hence

$$i(t) = \frac{q(t)}{\tau_L} = \frac{Q_0}{\tau_L} (e^{\lambda v(t)} - 1) = I_0 (e^{\lambda v(t)} - 1)$$

Diode Turn-On

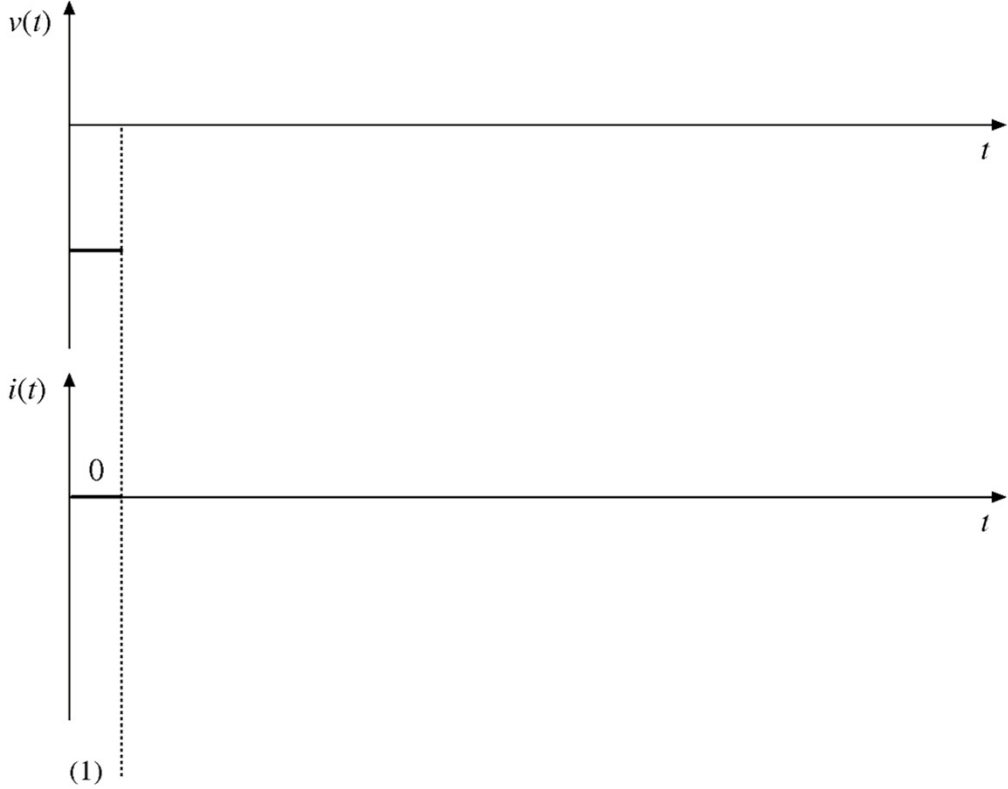
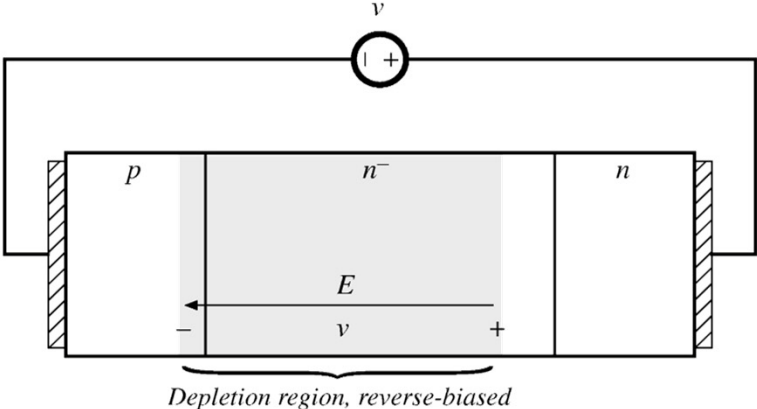

Diode Turn-Off

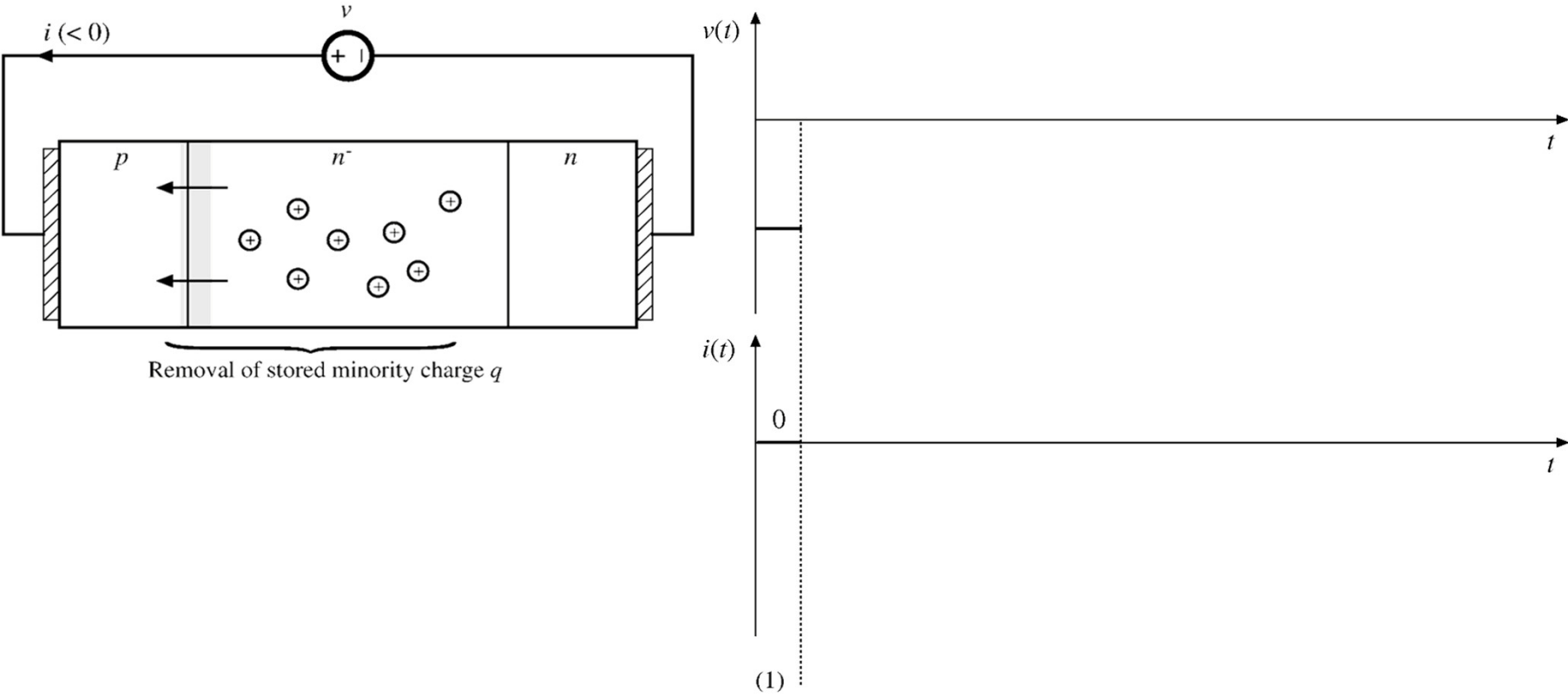

Diode Reverse Recovery

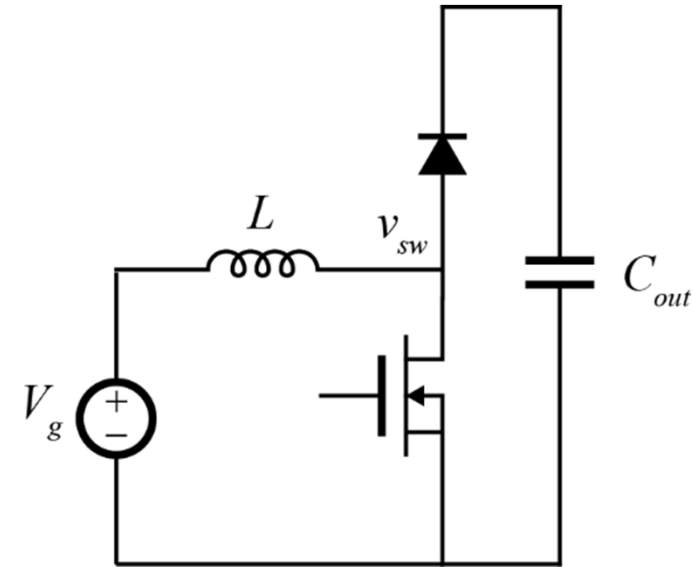
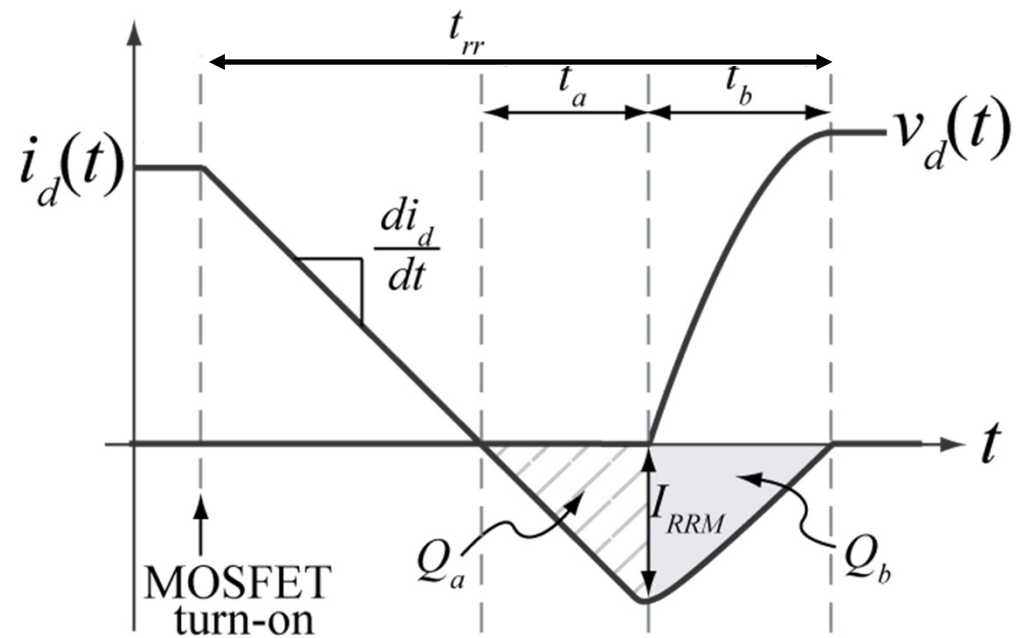

Datasheet RR Characteristics

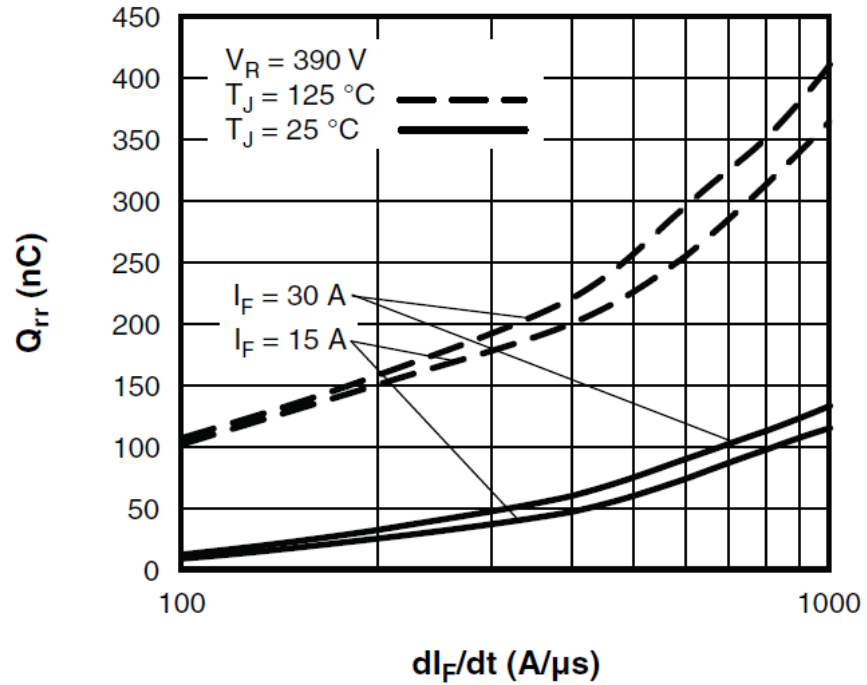

Fig. 10 - Typical Stored Charge vs. di_F/dt

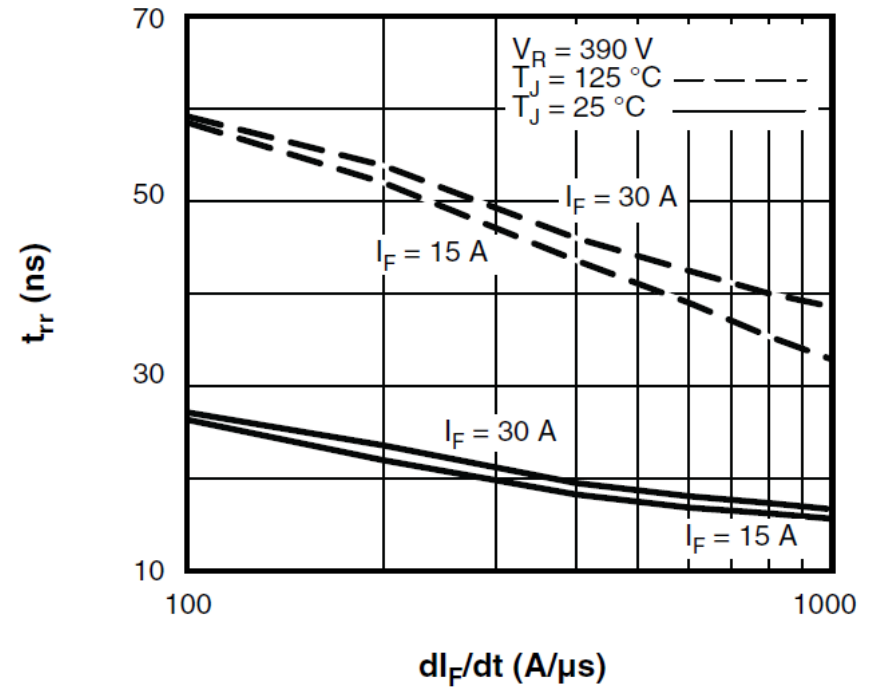

Fig. 9 - Typical Reverse Recovery Time vs. di_F/dt