

Dynamic Modeling Introduction

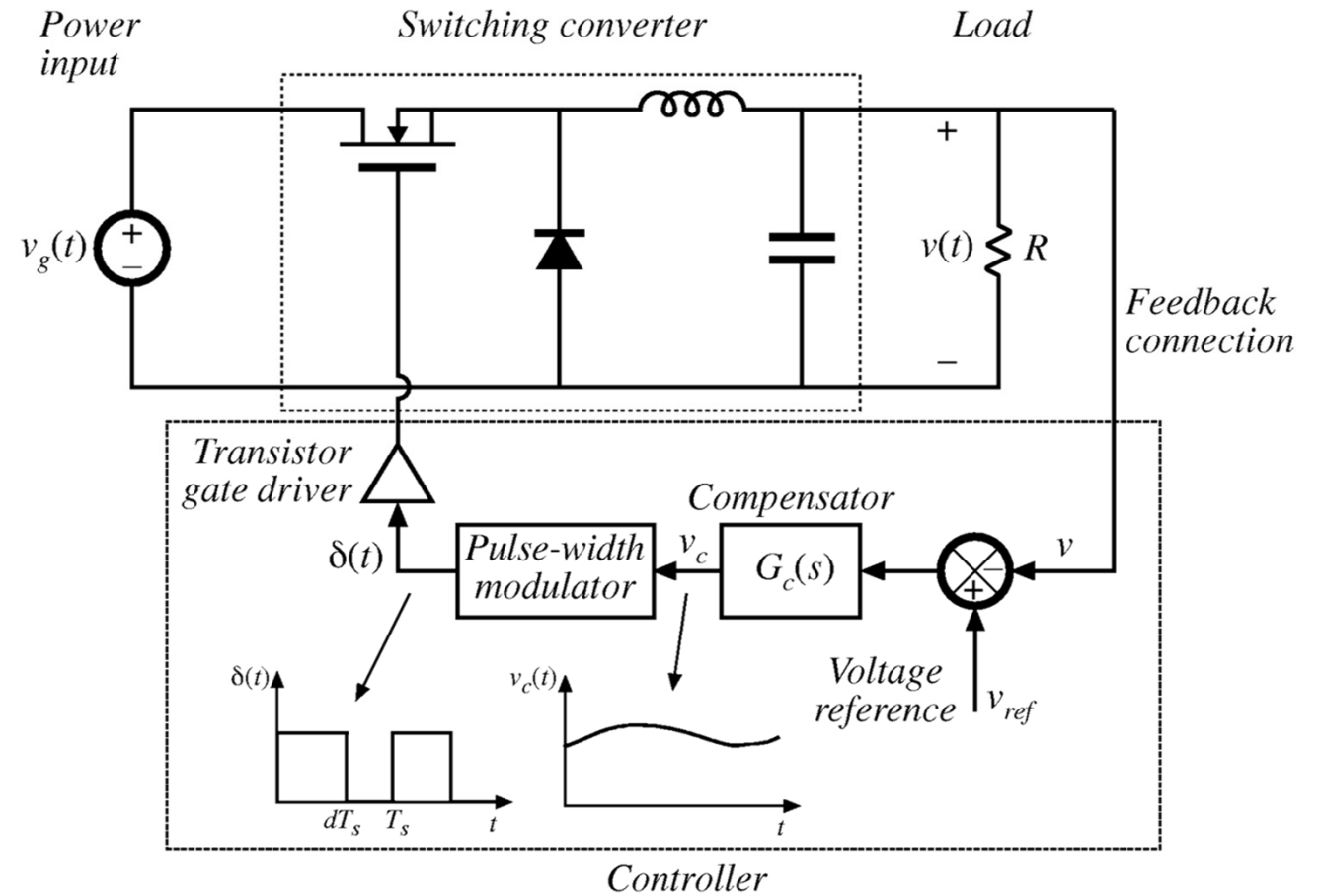

Control Objectives and Inputs

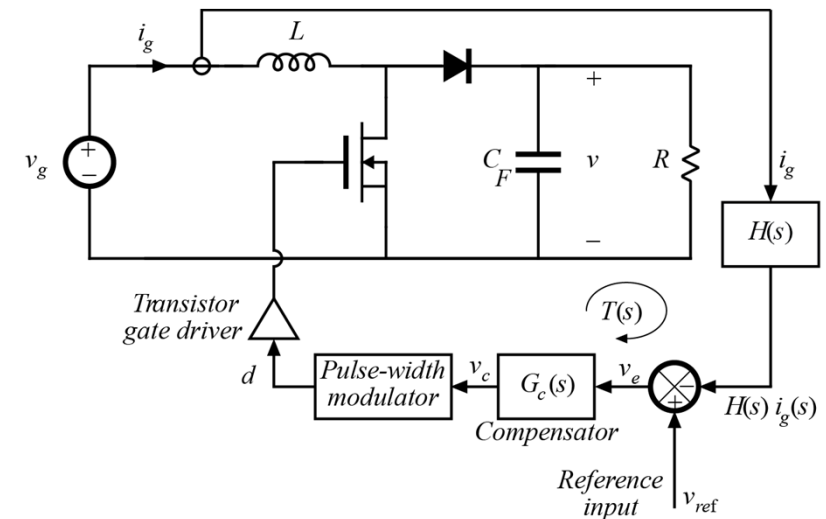
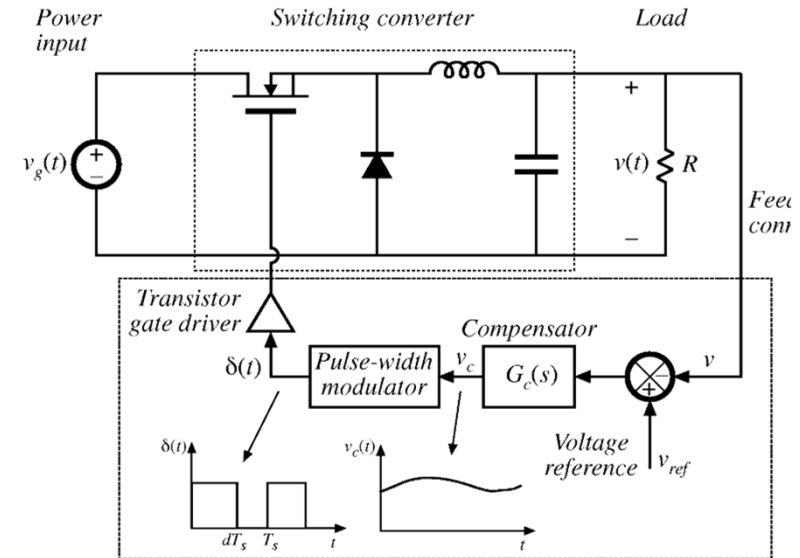

PWM Spectrum

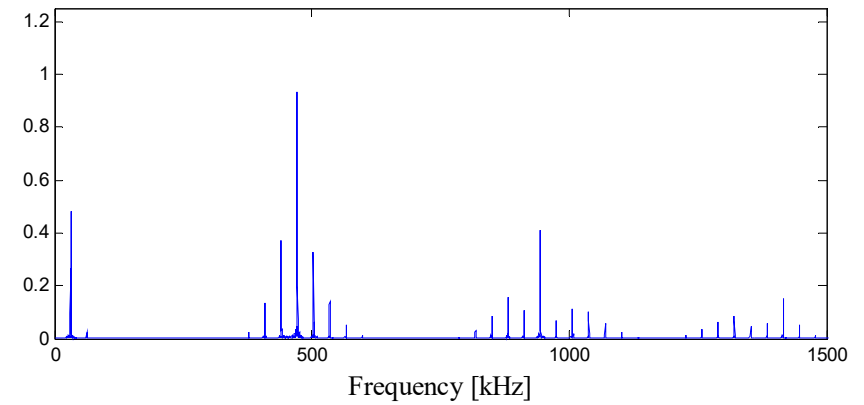
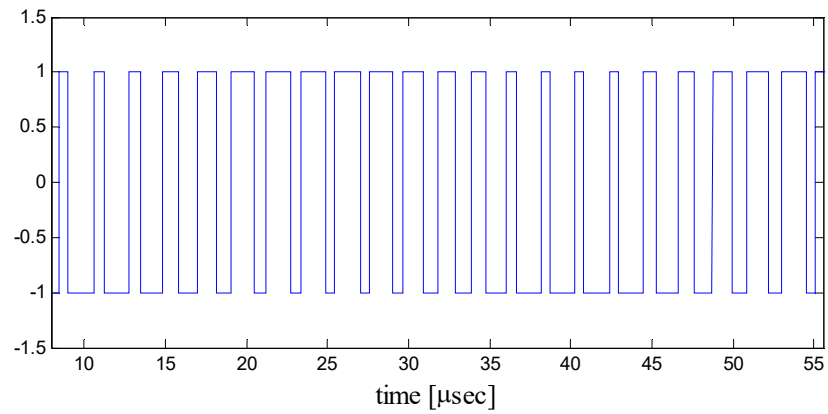
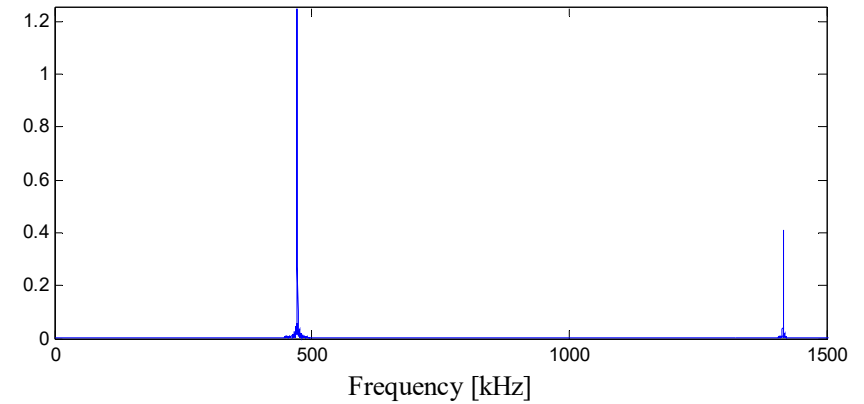
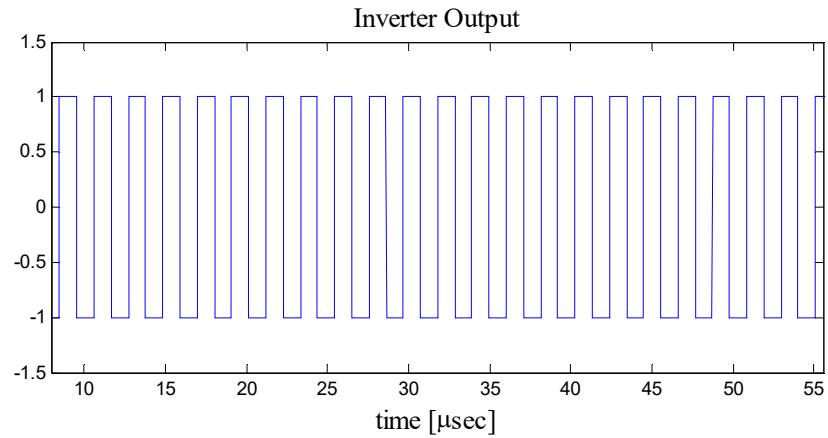

Neglecting The Switching Ripple

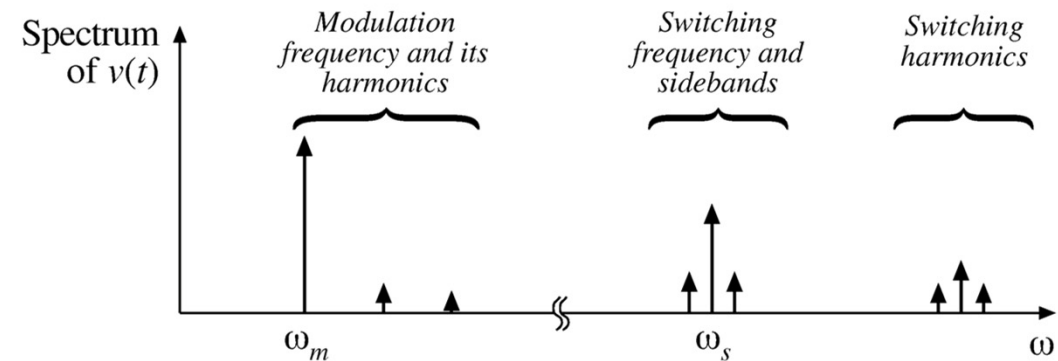
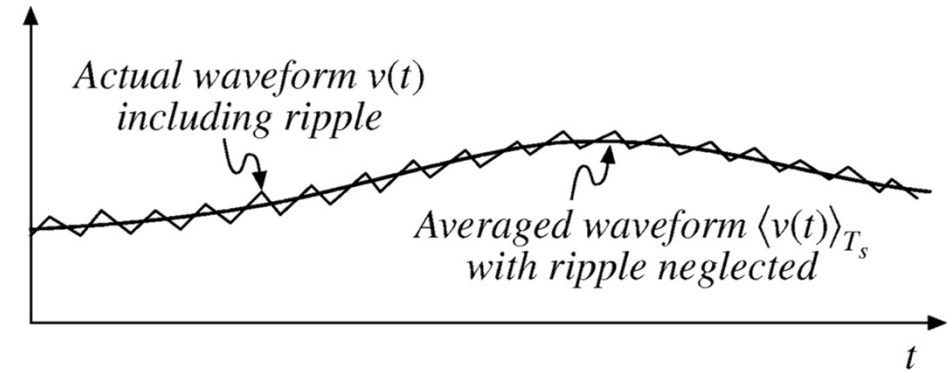
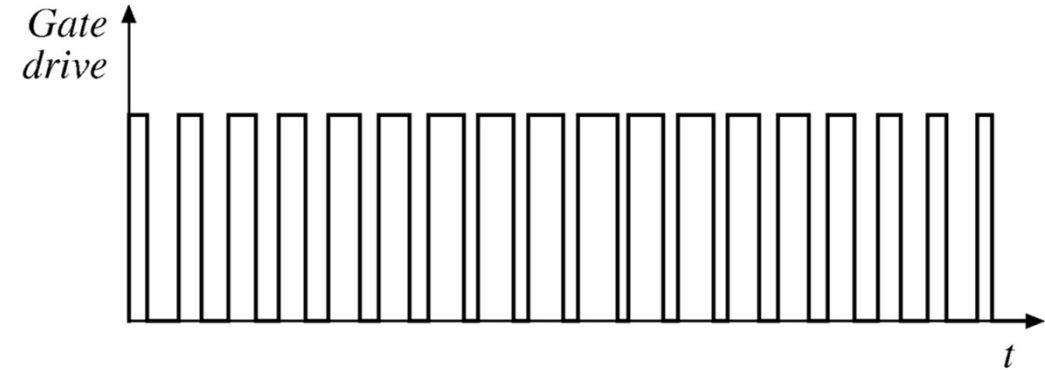

Output Voltage Spectrum

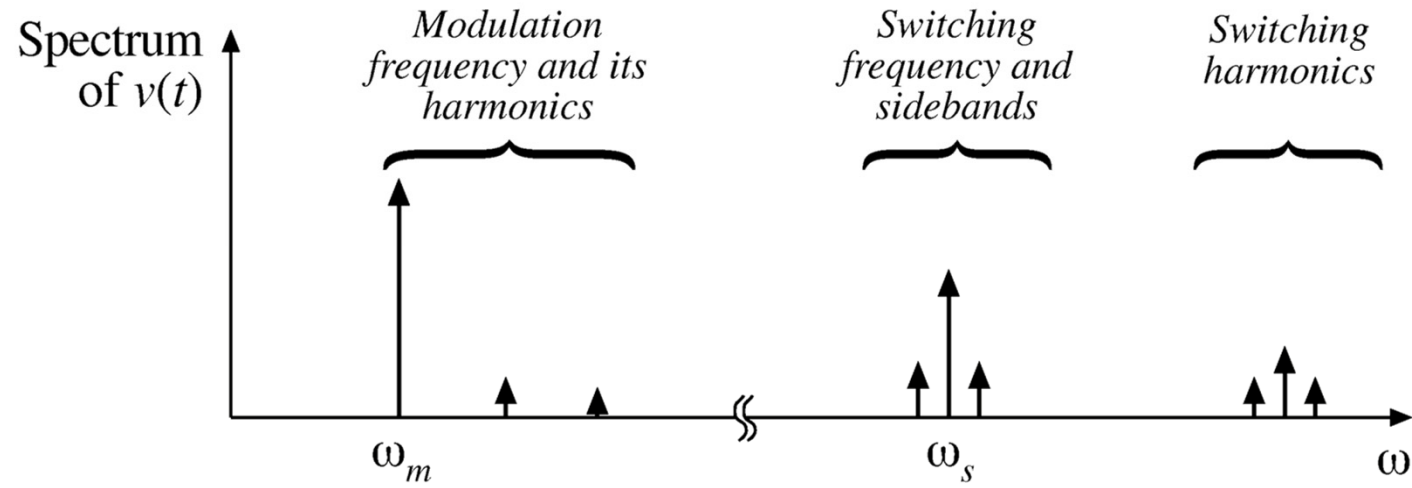

Objectives of AC Modeling

Low-frequency Averaging

Averaging in Steady-State

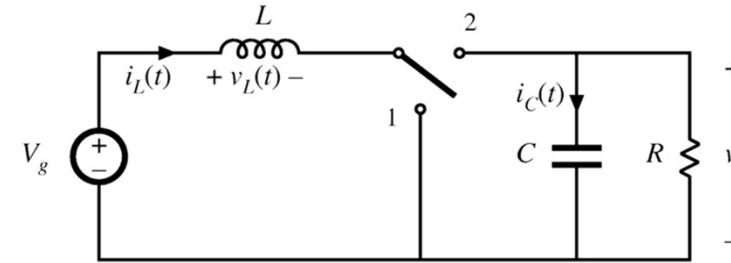

Averaging in Transient Operation

