

HIP2103/HIP2104, 3-phase, Full, or Half Bridge Motor Drive User's Guide

Introduction

The HIP2103-4DEMO1Z is a general purpose motor drive with a microprocessor controller. Three motor drive topologies are supported: 3-phase for BLDC motors, and full and half bridge for conventional brushed DC motors. Hall effect rotor position sensors are used to control the switching sequence of the BLDC topology (not required for the brushed DC motors).

The operating bridge voltage can vary between 13V and 50V and the maximum motor current is 20A (with sufficient air flow). This motor drive can be used as a design reference for multiple applications including e-bikes, battery powered tools, electric power steering, wheel chairs, or any other application where a brushed or brushless DC motors are utilized. Because this demonstration board is primarily intended to highlight the application of the HIP2103 and HIP2104 3-phase MOSFET drivers with no specific motor targeted, the control features are limited to simple functions such as start/stop, reverse rotation, and braking. Open loop speed control is implemented. More advanced control features such as torque control, speed regulation and regenerative braking are not implemented because these methods require close integration with the characteristics of the motor load dynamics.

Important

Because Hall sensor switching logic sequences for BLDC motors are not all the same, this demo board supports most, if not all, variations of sequence logic. Please refer to the sequence charts at the end of this application note to verify that your desired sequence is implemented. If you require a different sequence for your specific motor application or if you need help identifying the correct switching sequence for your specific motor, please contact Intersil prior to ordering this demo board for possible support for a new switching sequence.

Specifications

Motor topologies	3-phase BLDC motor with Hall sensors Full bridge for brushed DC motors (bidirectional) Half bridge for brushed DC motors (unidirectional)
Operating voltage range	13 - 50VDC
Maximum continuous bridge current	20A (with sufficient air flow)
Hall sensor bias voltage	3.3V, 15mA
PWM switching frequency	~20kHz

Scope

This application note covers the design details of the HIP2103-4DEMO1Z with a focus on the design implementation of the HIP2103 and HIP2104 drivers including recommended support circuits.

Also covered is the design method of the bipolar current sensing feature. Presently, current sensing on this demo board is used only for pulse-by-pulse current limiting but an analog signal proportional to the motor current is available on board as a design reference.

The microcontroller firmware is also provided as a reference but the only support offered by Intersil will be for bug corrections and for adding more switching sequences. Please refer to Microchip for details on the use of the PIC18F2431.

Physical Layout

The HIP2103-4DEMO1Z board is 90mm by 82.5mm. The tallest component is a 470µF capacitor. The total height is 32mm with standoffs. The Hall effect rotor position sensor inputs are miniature terminal blocks. The phase terminal blocks are high current outputs rated for 20A.

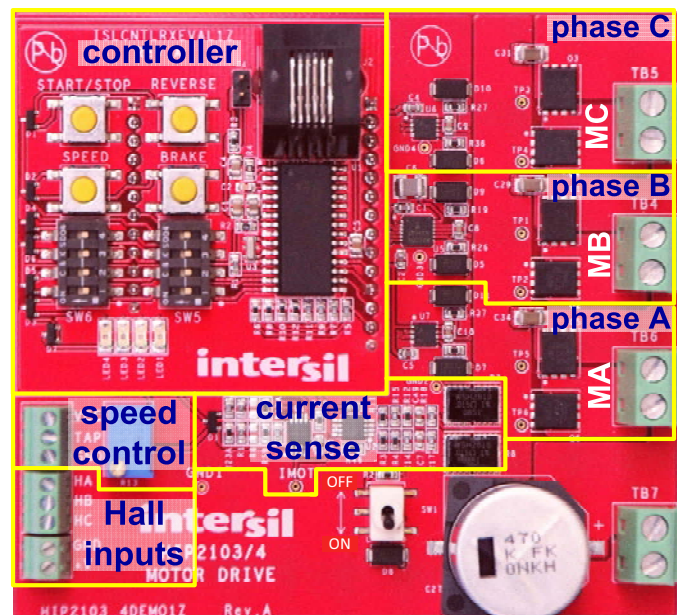

FIGURE 1. HIP2103-4DEMO1Z INPUTS AND OUTPUTS

The **controller** section is a daughter card which contains push buttons for reset, brake, reverse, and start/stop functions. Also on the controller card are dip switches for configuration, LEDs for status, and a programming port. As an option, a customer designed controller daughter card can be substituted for the Intersil supplied controller.

Application Note 1899

The **speed control** section includes an on-board potentiometer for speed control or an optional external potentiometer can be connected to the signal terminal block.

The **current sense** section includes current amplifiers, comparators, and current sense resistors.

The **Hall Inputs** section is the terminal connections from the BLDC motor for the hall sensors and the 3.3V bias for the sensors.

The **phase A, B, and C** sections include the HIP2103/4 drivers, bridge FETs, and power terminal connections for the motor.

For those customers who would like to modify the firmware of the PIC18F2431 microcontroller, an RJ11 connector is provided for easy connection with Microchip firmware development tools (not provided or supported by Intersil).

Block Diagram

The HIP2103-4DEMO1Z is composed of seven major circuit function illustrating the use of several Intersil products. The following descriptions reference Figure 2.

Bias Supplies

Two bias supplies are required and are provided by one HIP2104 driver with internal linear regulators. The VCC output (3.3V) of the HIP2104 provides the bias to the controller, Hall sensors, and LEDs. The VDD output (12V) of the HIP2104 provides its own bias

for its driver portion and also to the other two HIP2103s (which do not have internal regulators).

HIP2103 and HIP2104 Drivers

The one HIP2104 and the two HIP2103s are the featured Intersil parts. Each driver's outputs (HO and LO) are connected to a half bridge pair of SiR662DP-T1-GE3 power FETs operating with a PWM frequency of 20kHz. Associated with the HIP2103s and HIP2104 are the necessary support circuits such as the decoupling and boot capacitors.

Controller

The microcontroller is located on a daughter card to provide the customer with the option to incorporate their own controller design. The features on the controller daughter card are configuration dip switches, status LEDs, a programming port, and 4 push-buttons.

The Hall sensor inputs are decoded by the microcontroller to provide the appropriate switching sequence signals to the 3 HIP2103/4s to drive the six bridge FETs that drive a 3-phase BLDC motor. The SW5 dip switch is used to select the appropriate switching sequence for the BLDC motor.

With appropriate setting to the SW6 dip switch, the motor driver can be configured with a full bridge topology for bidirectional control of a conventional brushed DC motor. A half bridge option is also provided to drive a brushed DC motor without bidirectional control. See Table 1 for more details on configuring SW6.

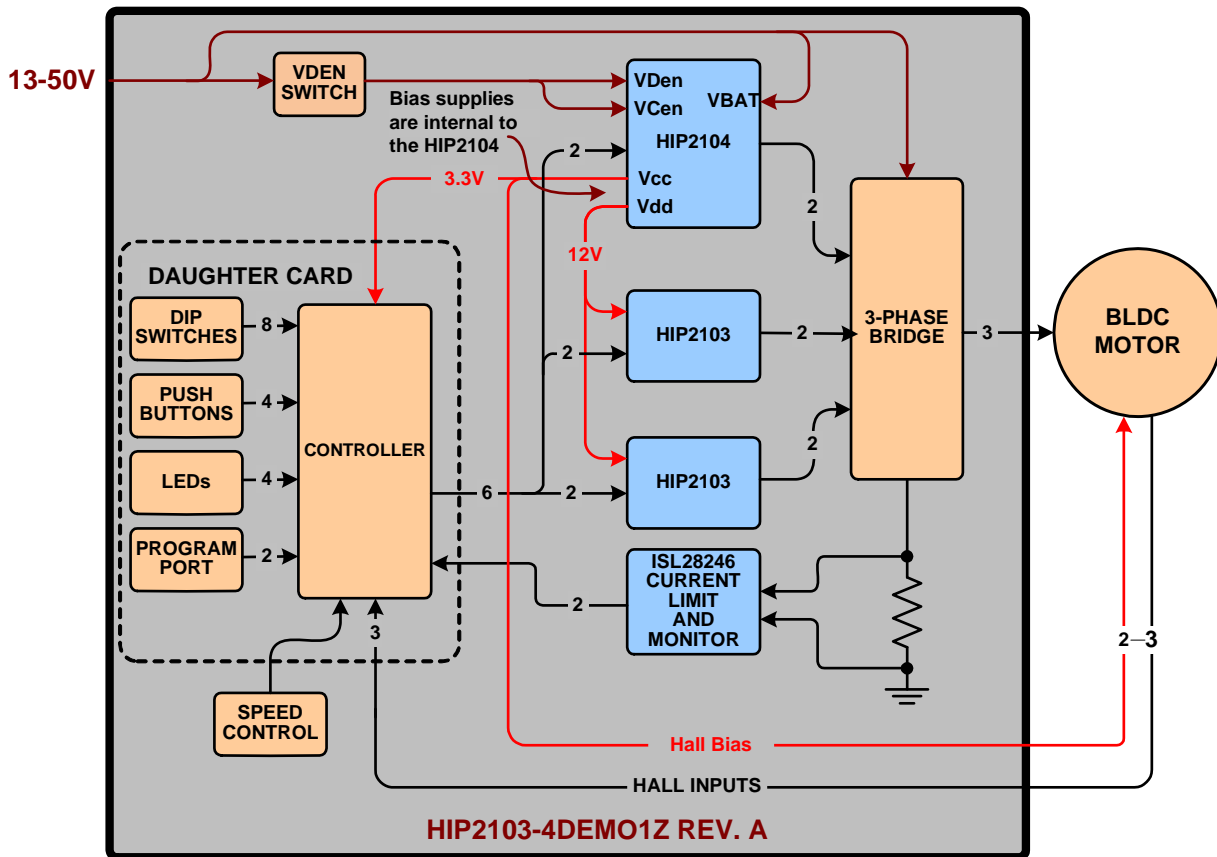

FIGURE 2. HIP2103-4DEMO1Z BLOCK DIAGRAM

In addition to decoding the Hall sensors, the microcontroller reads the push buttons to invoke the various operating functions of the motor, and controls the status LEDs.

The microcontroller firmware is provided for reference but the only support offered by Intersil will be for bug corrections and for adding more switching sequences. Firmware for this demo board can be found on the Intersil website.

Speed Control

The on-board potentiometer (or an optional external pot) is monitored by the microcontroller to provide a duty cycle to the motor that is proportional to the tap voltage of the potentiometer and varies between 0% and 100% duty cycle. This proportional duty cycle is open loop and is independent of the bridge voltage. Consequently, any motor voltage between 13V and 50V can be used with this demo board.

The Speed push button on the control card is not implemented in this design.

Current Sensing/Current Limit

Two Intersil low offset, dual op-amps (ISL28246) are used for current monitoring and current limiting. One op-amp is configured as a differential amplifier for Kelvin connections across the current sensing resistor. The diff-amp is biased so that zero motor current results with an output voltage that is 1/2 of the +3.3V bias. Consequently, positive bridge currents results with a current monitor signal that is greater than 1.65V (up to ~3.3V). Negative bridge currents (that occur with regenerative braking) is less than 1.65V (down to a minimum of ~0V). This "bipolar" analog signal can be monitored by the microcontroller for purposes such as torque control and/or regenerative braking.

The output of the analog differential amplifier is also connected to two op-amps configured as outside window comparators for pulse-by-pulse current limits for either positive or negative bridge currents. The OR'ed comparator outputs are sent to the microcontroller for pulse by pulse current limiting.

3-phase Bridge

The 3-phase bridge is composed of six SiR662DP-T1-GE3 power MOSFETS (60V, 60A). Each FET is driven by one of the six driver outputs of the HIP2103/4 MOSFET drivers. The dead time provided by the controller is 1 μ s which is sufficient for the default hardware configuration of the HIP2103-4DEMO1Z.

Related Literature

- [FN8276](#) 60V, 1A/2A Peak, 1/2 Bridge Driver with 4V UVLO
- [FN6321](#) ISL28246, 5MHz, Single and Dual Rail-to-Rail Input-Output (RRIO) Op Amps

Setup and Operating Instructions

Required and Recommended Lab Equipment

- Lab supply or battery, 13V minimum to 50V maximum. The current rating of the lab supply must have sufficient capacity for the motor being tested. If a battery is the power source, it is highly recommended that an appropriate fuse be used.
- Bench fan (likely not needed)
- Test motor (3-phase BLDC or conventional brushed DC motor)
- Multichannel oscilloscope, 100MHz or greater
- Current probe for oscilloscope.
- Multimeter
- Temperature probe (optional)

Caution: Although the HIP2103-4DEMO1Z has large heat dissipating copper planes on the power FETS, if it is operated for an extended period at high power levels, it may be necessary to use a fan to keep the temperature of the bridge FETs to less than 100 °C as measured on the heat sink plane. The HIP2104 has internal thermal protection (150 °C) but this may not be sufficient to protect the power FETs from excessive temperature.

BLDC MOTOR SETUP (3-phase)

1. Connect the 3-phase motor leads to the MA, MB, and MC terminal blocks. For high current applications, it is recommended that both terminals of each block be used. It is also recommended that during initial setup the motor **not** be mechanically loaded.
2. Connect the HALL sensor leads of the motor to the HA, HB, and HC terminals. The +V bias (3.3V) and GND leads must all be connected.
3. Rotate the R13 potentiometer to the left (CCW) until it clicks. This will set the starting voltage on the motor to a minimum.
4. Eight different 6 step hall logic sequences are supported by the this demo board. Refer to Figures 14 and 15 to setup SW5 dip switch for the appropriate Hall logic.
5. The motor driver must also be configured for the required motor topology (3-phase, full or half bridge). For the BLDC motor, SW6:1 must be on and switches SW6:2, 3, 4 must be off. Refer to Table 1 for complete configuration details for SW6.
6. Ensure that the SW1 toggle switch is off. When this switch is off, the bias supplies (VDD and VCC) of the HIP2104 are off and consequently, the bridge FETs are also off.
7. With the lab supply turned off, connect the lab supply or the battery to the BATT terminal block. If a battery is used, the 470 μ F filter capacitor across the bridge may cause a spark when connecting to the terminal block.

Caution: Reverse polarity protection is not provided.

8. Ensure that the motor is securely mounted prior to proceeding with the following steps.

Caution: Do not exceed the maximum rated RPM of your motor.

Application Note 1899

9. Turn on the lab supply. Set SW1 (toggle switch) on. Observe that the four LEDs turn on and off, one after another.

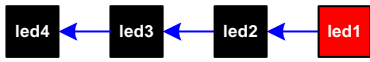

At initial turn on, leds will turn on and off one at a time starting with led1

This initial flash of the LEDs indicates that power has been applied. After the initial flash, all LEDs will be off. Operation of the motor is now possible. If all four LEDs are flashing simultaneously, SW6 is not configured correctly. Reconfigure SW6 then turn off, then on, the toggle switch to restart.

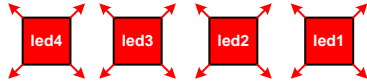

SW6 is not configured correctly

10. Press the Start/Stop push button once. The RUN LED (led1) will blink indicating that the motor has been started. The motor at this point may not be rotating because minimal voltage is being applied to the motor.



While the motor is rotating, the RUN LED is blinking

11. Slowly increase the voltage on the motor by rotating the potentiometer, R13, to the right (CW). At some point the motor will start to rotate slowly. The actual starting voltage is dependent on the specific motor being used.
12. If the motor is vibrating back and forth instead of rotating, it is possible that the Hall sensors or the motor leads were not connected correctly. If the correct switching sequence has been selected, all that should be necessary to correct this misbehavior is to swap two of the motors lead (or to swap two of the Hall sensor leads).
13. Continue to rotate the pot until the motor is running at a moderate speed of roughly 25%. Do not run the motor with maximum voltage until the setup check-out is completed.
14. Press again the START/STOP push button. The motor will free wheel to a stop and the blinking led1 will turn off.
15. Press again the START/STOP button. The motor will accelerate to the previous run speed (assuming that the potentiometer was not rotated). The blinking led0 will also turn on.



16. While the motor is running, press the REVERSE button. The RUN LED (led1) will turn off and the REVERSE LED (led2) will turn on without blinking. After a short pause while the motor is freewheeling to a stop, the motor will restart rotating in the opposite direction. The RUN LED will be blinking and the REVERSE LED will continue to be on.



17. Press again the REVERSE button. As before, the motor will stop. But this time the REVERSE LED will turn off. After a pause, the motor will restart but this time rotating in the forward direction.

18. While the motor is running, the motor can be hard braked by pressing the BRAKE push button.



The BRAKE LED (led3) will be on without blinking. When the motor is restarted, the BRAKE LED will turn off.

CAUTION: This braking method turns on simultaneously all of the low side bridge FETs. This will force the motor to a very rapid stop. If the motor is loaded, or if the motor is not designed for a rapid stop, mechanical damage to the motor or to the load can result. If you are not sure about using this braking method, only apply the brake when the motor speed is relatively slow.

19. If, while operating the motor turns off, and all 4 LEDs are blinking, the current limit shut-down has been activated after 255 consecutive pulse-by-pulse current limits. This may happen if the motor speed (with load) is accelerated too quickly, or if there is a fault with the motor or connections, or if the motor is stalled. The iLimit LED will turn on momentarily by itself if the overcurrent duration is less than 255 pulse-by-pulse current limits.

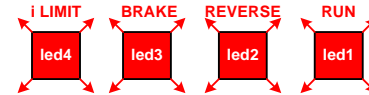

It is now safe to proceed with testing at higher power levels or speeds.

DC Motor Setup (Full Bridge)

The HIP2103-4DEM01Z can also be used to drive a conventional brushed DC motor. The setup procedure is essentially the same as the BLDC configuration except that Hall sensor inputs are not used and only two motor connections are used, MB (TB4) and MC (TB5). When configured in a full bridge topology, phase A (MA) is disabled by setting the corresponding HIP2103 to sleep.

To setup the motor driver for a full bridge topology, set SW6:2 to on and switches SW6:0, 3, 4 to off. Refer to Table 1 for complete configuration details for SW6.

As with the BLDC configuration, the motor rotation direction can be controlled. But unlike the BLDC configuration, the motor can be reversed even if it has not yet stopped rotating. Be cautious when reversing the motor before it has stopped rotating.

The motor can also be braked by grounding both motor leads similar to the BLDC motor.

DC Motor Setup (Half bridge)

The HIP2103-4DEM01Z can also be used to drive a conventional brushed DC motor with a half bridge Topology. The setup procedure is essentially the same as the BLDC configuration except that Hall sensor inputs are not used and only two motor connections are used, MB (TB5) and the negative connection of

Application Note 1899

BATT (TB7). When configured in a half bridge topology, phase A (MA) and phase B (MC) are disabled by configuring the corresponding HIP2103s to sleep.

The half bridge topology cannot reverse the direction of the motor.

To setup the motor driver for a half bridge topology, set SW6:1 to on and SW6:2 to on. Refer to Table 1 for complete configuration details for SW6.

TABLE 1. SW6 SETUP

		SWITCH POSITION			
		4	3	2	1
Motor TOPOLOGY	3 PHASE	off	off	off	on
	FULL BRIDGE	off	off	on	off
	HALF BRIDGE	off	on	off	off
Factory test		on	off	off	off
Other settings (error)		-	-	-	-

Theory of Operation (3-Phase)

The HIP2103-4DEMO1Z demonstration board is a general purpose 3-phase BLDC motor controller. Three half bridge power circuits drive the motor as shown in Figure 3.

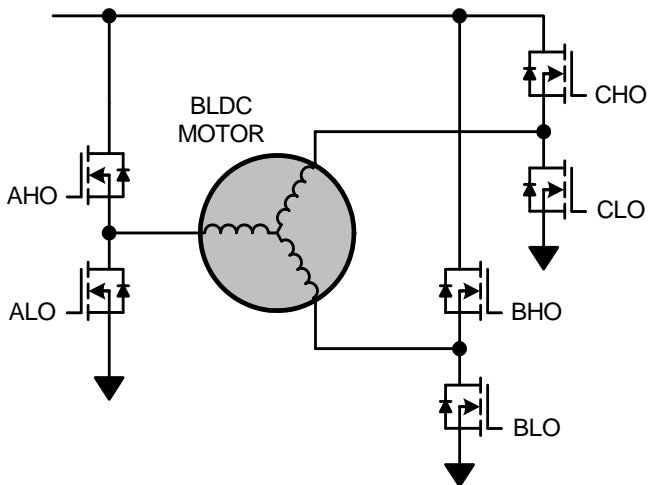

FIGURE 3. BASIC BLDC MOTOR POWER TOPOLOGY

Three 6 step bridge state logic diagrams, illustrated in Figure 4, are used to drive the motor. The bridge state logic diagrams represents the logic status of the each half bridge but the actual voltage applied to the motor appears much differently. Figure 5 illustrates the bridge status logic vs the actual voltage waveforms applied to each motor lead.

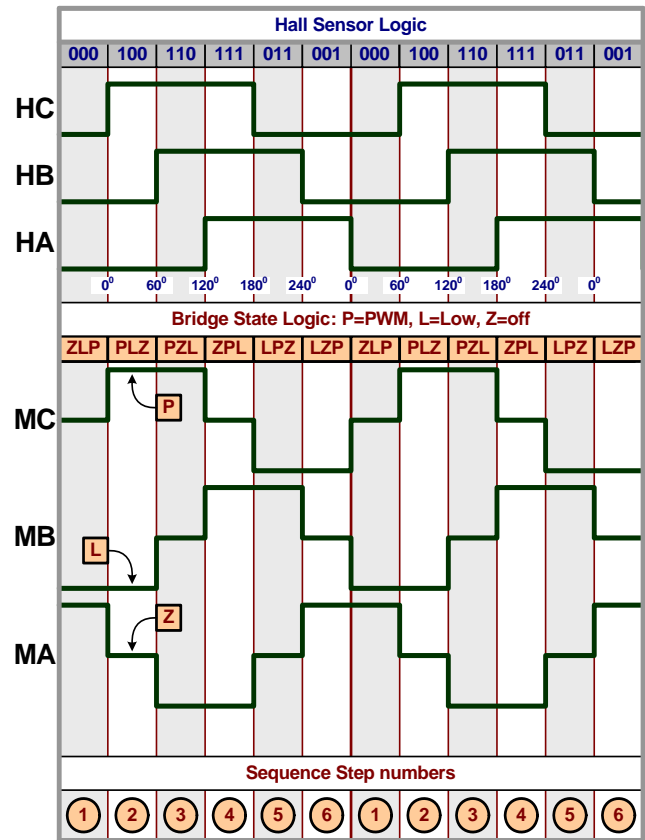

FIGURE 4. HALL SENSOR LOGIC vs BRIDGE STATE LOGIC

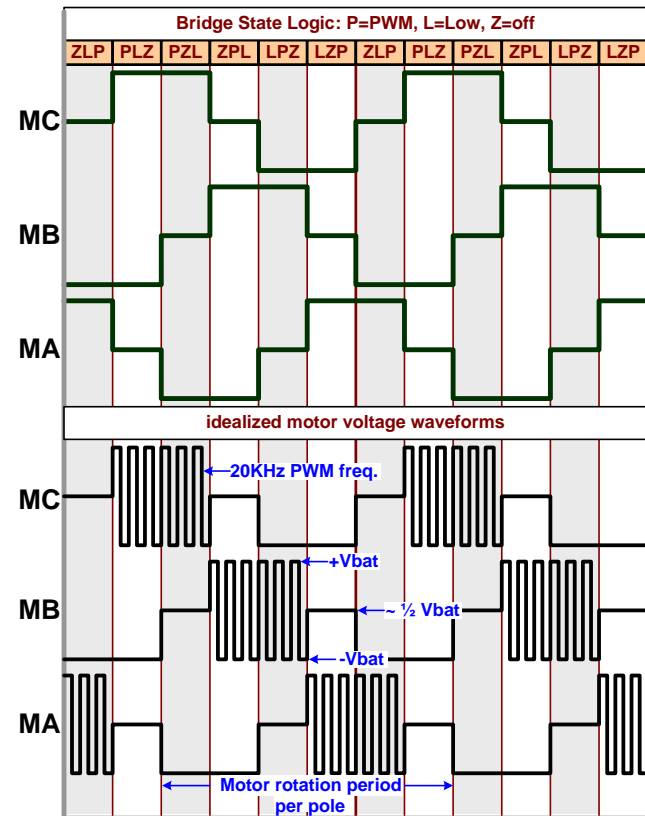

FIGURE 5. BRIDGE STATE LOGIC vs MOTOR VOLTAGE

Application Note 1899

The HIP2103-4DEMO1Z demo board has 6 gate drive outputs, two per HIP2103/4 (HO and LO), to control the six bridge FETs individually. If the gate drives for both FETs of one half bridge are low, current will not flow in the corresponding motor lead (high impedance or Hi-Z). If the gate drive for the low FET is high and the gate drive for the high FET is low, then the phase node of that half bridge, and the corresponding motor lead, is connected to ground (Low). If the low and high gate drives are complementary driven, the phase node is pulse width modulated (Pwm) to control the average voltage on that motor lead.

The motor rotation period and the amplitude of the bridge voltage waveforms are modified by the microcontroller to control the speed of the motor. Pulse width modulation is used to modify the amplitude of the voltage waveforms and the motor rotation period is established by the rotor position hall sensors that signal the controller to change the switching sequence. Typical hall sensor logic is illustrated in Figure 4. Each hall logic diagram, HA, HB, and HC, correspond respectively to the bridge state logic diagrams, MA, MB, and MC. For example, the transition of the hall sensor logic, from step 1 to 2, results with the drive waveform transition of ZLP to PLZ where P, L, and Z define the state of each half bridge.

Switching Sequence Phase Currents

The following motor winding diagrams illustrate how currents flow in a 3-phase BLDC motor during each switching period of the 6 step voltage waveform. These diagrams are for a very simple motor with only 6 stator poles. Most 3-phase motors have more stator poles (multiples of 6) to reduce torque modulation (cogging) but the principles of operation are the same.

Each phase winding is color coded and black arrows indicate the direction of positive current in that winding for each step. As described in Figure 6, the half bridge state of each motor lead, MA, MB, or MC, is labeled with P, L, or Z. Observe that the active coils are highlighted. The inactive coils (those with no current) are white.

The dark gray structures are the permanent magnets that are mounted on the light gray rotor. The bold black arrow is the flux vector of the permanent magnets. The bold dark blue arrow is the magnetic flux vector generated by the active coils for each waveform step. The switching step occurs when these two vectors are perpendicular for maximum torque. Notice how the flux vectors are rotating counter clockwise, 60 degrees for each step.

This tutorial for BLDC motors is very fundamental. For more information about a specific motor, please contact the motor manufacturer.

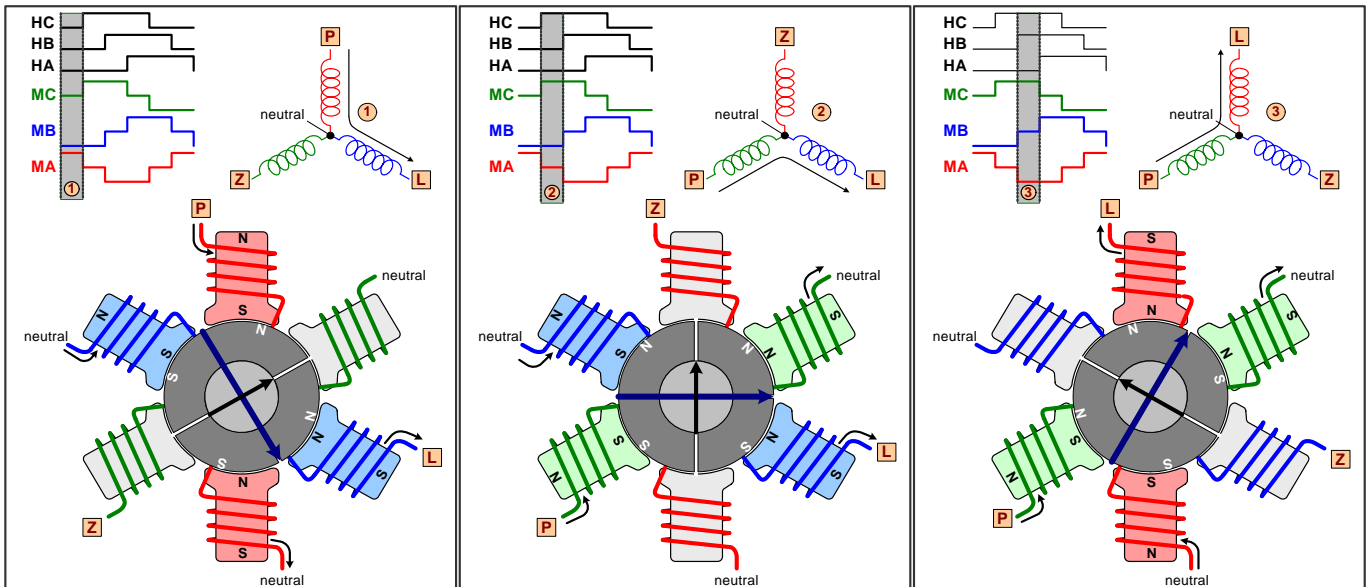

FIGURE 6. SEQUENCE STEPS 1 TO 3

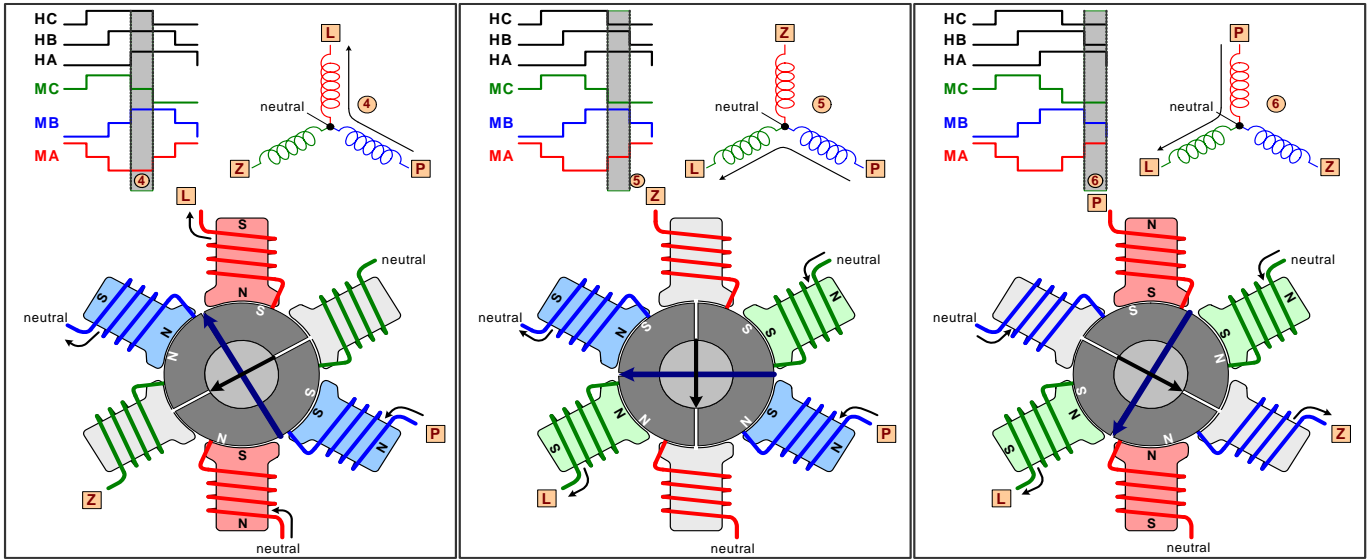

FIGURE 7. SEQUENCE STEPS 4 TO 6

HIP2103_4 Circuit Description

The simplified schematic of Figure 8 illustrates the three power phases of the motor driver. Each phase has identical components (except for the one HIP2104 and two HIP2103s). For specific component values and complete circuit details, please refer to the BOM and schematic found at the end of this application note.

customer may change the resistor values or even remove the diodes to suit the customer's application needs.

The HIP2103/4 drivers do not have internal dead time features. A dead time is provided by the controller and can be adjusted by the SW6 dip switch settings.

Current Monitor and Current Limit

There are two current control features in the HIP2103-4DEMO1Z. A linear current monitor op amp, U2, amplifies the voltage across R21 and R22. This op amp is configured as a true differential amplifier to allow Kelvin connections across the current sensing resistors (see Figure 9). R3 and R4, each 32.4kΩ, have a Thevenin equivalent value that is the parallel value of R3 and R4 (or 1/2 of 32.4kΩ). The Thevenin equivalent voltage also is 1/2 of the bias voltage of 3.3V. Consequently, the output of the differential amplifier is offset by +1.65V (see Figure 10).

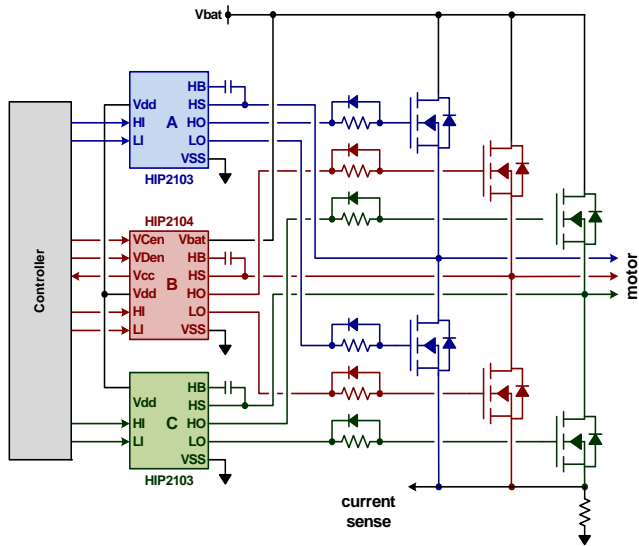

FIGURE 8. SIMPLIFIED 3-PHASE BRIDGE

The HIP2104 (red) provides the Vcc (3.3V) bias for the controller and the Vdd bias (1.2V) for itself and for the two HIP2103s (green and blue).

Series connected gate resistors on each bridge FET are used to reduce the switching speed to help minimize EMI radiating from the power leads to the motor. The diodes in parallel with the FET gate resistors are used to provide rapid turn off of the FETs. The

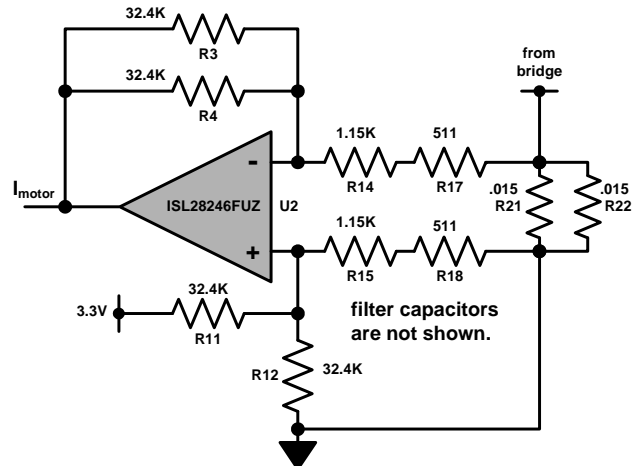

FIGURE 9. DIFFERENTIAL CURRENT MONITOR AMPLIFIER

Application Note 1899

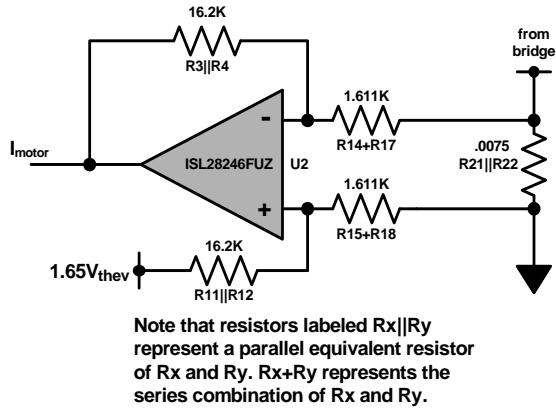

FIGURE 10. THEVENIN EQUIVALENT DIFFERENTIAL AMPLIFIER

The current monitor output, I_{motor} , digitized by the microcontroller, can be used to control the torque of the motor or to limit the battery recharging current during regenerative braking. Because of the offset voltage on the current monitor output, signals above 1.65VDC represents positive motor current and signals less than 1.65VDC represent negative motor current. (Note that this hardware feature is provided for customer evaluation but is not implemented in the microcontroller firmware.)

The output voltage of the differential amplifier is (with superposition):

$$V_{out_{CS}} = \frac{(R3 || R4)}{(R14+R17)} \times \frac{(R21 || R22)}{[(R3 || R4) + (R14+R17)]} \times I_M + \frac{(R15+R18)}{[(R11 || R12) + (R15+R18)]} \times 1.65V \quad (EQ. 1)$$

where I_M is the bridge current (motor current), $R3 || R4 = R11 || R12$, and $(R14+R17) = (R15+R18)$ (as required for the diff-amp topology).

Using the default values of the HIP2103-4DEMO1Z, Equation 1 simplifies to:

$$V_{out_{CS}} = [16.2K / 1.661K] \times (.0075) \times I_M + 1.661K / (16.2K + 1.022K) \times (16.2K + 1.611K) / (1.611K) \times 1.65V$$

or

$$V_{out_{CS}} = 0.07315 \times I_M + 1.65V \quad (EQ. 2)$$

The I_{motor} signal is monitored by two comparators. See Figure 11. The output of the upper U3 comparator is biased to go low when the positive motor current exceeds ~ 20A. Conversely, the output of the lower comparator is biased to go low when the negative motor current exceeds ~-20A.

The OR'ed outputs of these two comparators is monitored by the microcontroller. Pulse-by-pulse current limiting is provided on each negative transition. After 256 consecutive pulse limits, all the bridge FETs are permanently turned off and the current limit alarm LED (led3) is turned on.

There are two different methods to change the pulse-by-pulse current limit. The easiest method is to change the value of the current sensing resistors R23 and R24. For example, removing R24 halves the pulse by pulse current limit to $\pm 10A$ while not affecting the full scale I_{motor} output signal.

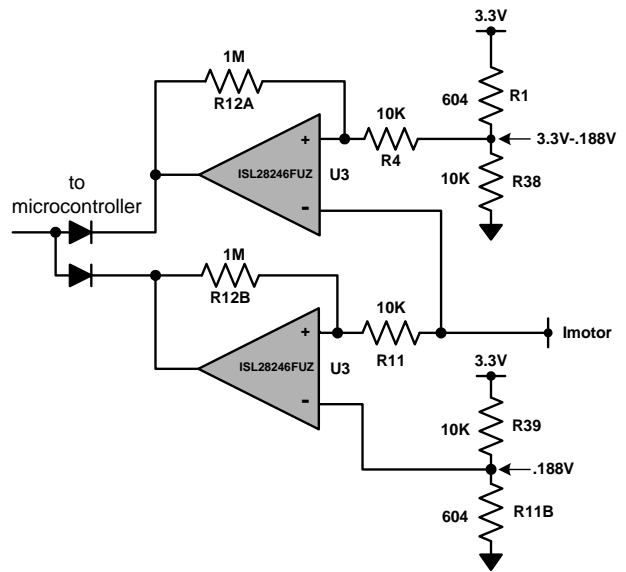

FIGURE 11. PULSE-BY-PULSE CURRENT LIMIT COMPARATORS

Equation 3 calculates the value of the current sensing resistors to set the pulse-by-pulse current limit at a desired level without changing the full scale output voltage swing of the I_{motor} signal. This equation assumes that the only change made to the HIP2103-4DEMO1Z is modifying the values of the current sensing resistors R23 and R24.

$$R21 || R22 = [(1.65 - .188)V / (16.2K / 1.661K)] / I_m \quad (EQ. 3)$$

For example: for $I_{limit} = \pm 5A$,

$$R21 || R22 = [(1.65 - .188)V / (16.2K / 1.661K)] / 5$$

$$R21 || R22 = 0.030\Omega$$

An alternative method for changing the pulse-by-pulse current is to change the gain of the diff-amp.

For example, if it is desired to decrease the current limit to 10A without changing the current sense resistors, R21 and R22, the gain of the diff-amp can be increased. Equation 4 illustrates this method that reduces the value of R17 (and consequently R18) to increase the gain of the diff-amp.

Equation 4 sets the positive current limit bias voltage.

$$R17 = (R3 || R4) / [(1.65 - .188)V / (R21 || R22 \times 10A)] - R14$$

or

$$R17 = 16.2K / [1.462V / (.0075 \times 10A)] - 511 = 320 \quad (EQ. 4)$$

Because the diff-amp topology requires symmetry, R18 must also be changed to 320.

In the above examples both the positive and negative current limit value are equal in absolute values. It is acceptable to have different limits for the positive and negative values.

Application Note 1899

Selecting the Correct Switching Sequence

In the previous discussion describing the operation of a BLDC motor, a specific hall logic pattern was used in Figure 4. Unfortunately, not all BLDC motors use this logic pattern. In all cases, the three hall signals are phase shifted by 60 degrees but the logic polarity can be different. Also, because the 0 degree

start position is not standardized, two rotation cycles are illustrated so that any start position can be identified.

The following charts define all possible combinations of hall logic. It is necessary that the hall sensor logic that matches your motor is selected by correctly setting the dip switch prior to applying power to the HIP2103-4DEMO1Z. Known specific motor part numbers are labeled in green boxes.

Dip switch positions hall sensor logic options are defined by the blue boxes: **0011**

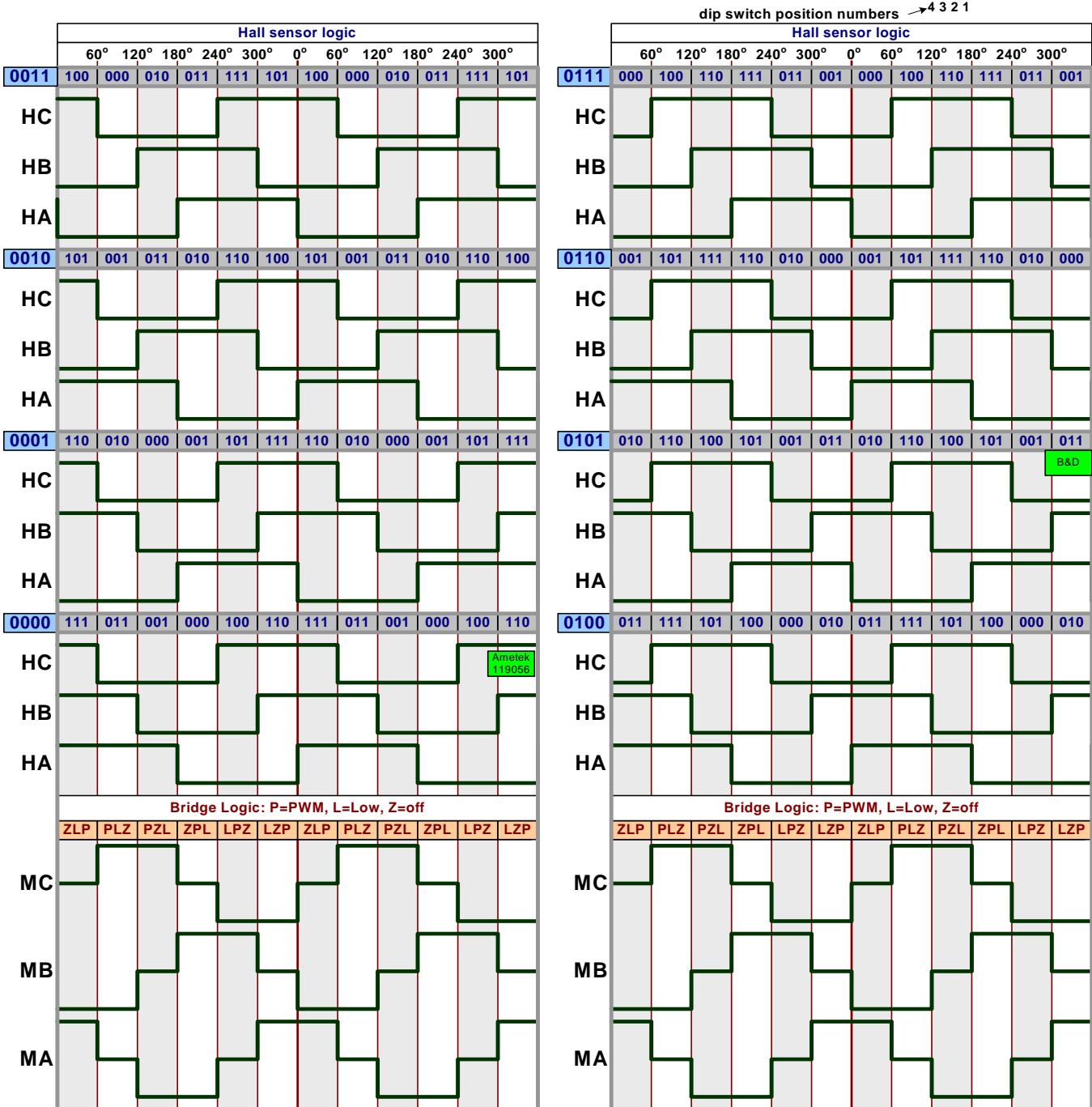

FIGURE 12. HALL LOGIC OPTIONS, FIRST CHART

Application Note 1899

Selecting the Correct Switching Sequence

Notice that the dip switch settings for these Hall sensor logic charts are the same as on the previous page. This is not an error.

Dip switch positions hall sensor logic options are defined by the blue boxes: **0011**

dip switch position numbers → 4 3 2 1

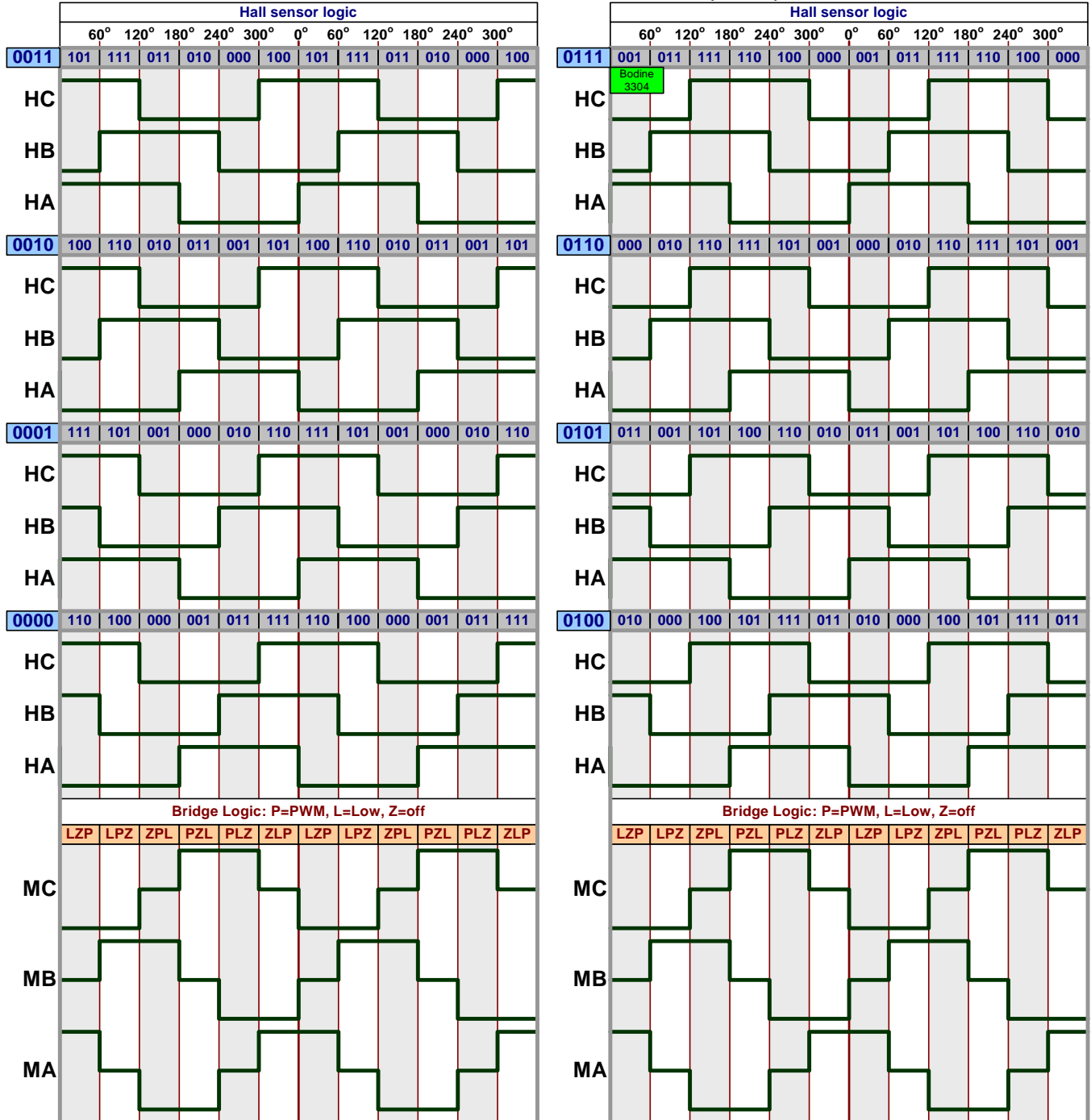

FIGURE 13. HALL LOGIC OPTIONS, SECOND CHART

Bill of Materials, Mother Board

PART NUMBER	QTY	REF DES	MANUFACTURER	DESCRIPTION
1725656	1	TB3	PHOENIX-CONTACT	100 Mil Micro-Pitch Terminal Block
1725669	2	TB1, TB2	PHOENIX-CONTACT	100 Mil Micro-Pitch Terminal Block
1729018	4	TB4-TB7	PHOENIX-CONTACT	200 Mil PCB Connector Terminal Block
3299W-1-103-LF	1	R13	BOURNS	TRIMMER POTENTIOMETER (RoHS COMPLIANT)
90147-1112	1	J1	MOLEX	12 PIN SINGLE ROW VERTICAL PCB FEMALE CONNECTOR
90147-1114	1	J3	MOLEX	14 PIN SINGLE ROW VERTICAL PCB FEMALE CONNECTOR
BAT54A	1	D1	DIODES	30V Schottky Diode
C1608X7R1C105K	4	C1, C2, C4, C5	TDK	MULTILAYER CAP
EEVFK1K471M	1	C27	PANASONIC	Aluminum Elect SMD Cap
ES1B	7	D5-D11	FAIRCHILD	1A 150V Fast Rectifier Diode
GT11MSCBETR	1	SW1	C&K	SPDT On-None-On SM Ultraminiture Toggle Switch
H1045-00103-50V10	1	C41	GENERIC	Multilayer Cap
H1045-00104-25V10	5	C8-C10, C38, C40	GENERIC	Multilayer Cap
H1045-00472-50V10	2	C7, C49	GENERIC	Multilayer Cap
H1065-00105-100V10	3	C29, C31, C34	GENERIC	Multilayer Cap
H1082-00225-100V10	1	C6	GENERIC	Ceramic Chip Cap
H2505-DNP-DNP-R1	3	R5, R6, RJ3	GENERIC	Metal Film Chip Resistor (Do Not Populate)
H2511-00330-1/16W5	6	R19, R26, R27, R36, R37, R40	GENERIC	Thick Film Chip Resistor
H2511-00R00-1/16W	2	RJ1, RJ2	GENERIC	Thick Film Chip Resistor
H2511-01000-1/16W1	2	R2, R46	GENERIC	Thick Film Chip Resistor
H2511-01002-1/10W1	3	R28-R30	GENERIC	Thick Film Chip Resistor
H2511-01002-1/16W1	7	R31-R33, R59, R60, R23A, R23B	GENERIC	Thick Film Chip Resistor
H2511-01004-1/16W1	2	R12A, R12B	GENERIC	Thick Film Chip Resistor
H2511-06040-1/16W1	2	R1, R11B	GENERIC	Thick Film Chip Resistor
H2511-03242-1/16W1	4	R3, R4, R11, R12	GENERIC	Thick Film Chip Resistor
H2511-01151-1/16W1	2	R17, R18	GENERIC	Thick Film Chip Resistor
H2511-05110-1/16W1	2	R14, R15	GENERIC	Thick Film Chip Resistor
HIP2103FRTAZ	2	U6, U7	INTERSIL	60V Half Bridge Driver with 4V UVLO
HIP2104FRAANZ	1	U5	INTERSIL	60V Half Bridge Driver with 4V UVLO, 3.3VCC

Bill of Materials, Mother Board (Continued)

PART NUMBER	QTY	REF DES	MANUFACTURER	DESCRIPTION
ISL28246FUZ	2	U1,U2	LINEAR	DUAL RAIL TO RAIL OUTPUT AMPLIFIER (Pb-Free)
SiR662DP-T1-GE3	6	Q1-Q6	VISHAY	N-Channel 60V 60A WFET
TP_20C40P-DNP	11	TP1-TP6, GND1-GND4, IMOT	GENERIC	Test Point .040 Pad 0.020 Thole (Do Not Populate)
WSH2818R0150FE	2	R7, R8	VISHAY	SURFACE MOUNT POWER METAL STRIP RESISTOR

Bill of Materials, Daughter Card

PART NUMBER	QTY	REF DES	MANUFACTURER	DESCRIPTION
555165-1	1	J2	TYCO	Phone Jack Connector
597-3111-402	4	LED1-LED4	Dialight	Surface Mount Red LED
90147-1112	1	J1	MOLEX	12 PIN SINGLE ROW VERTICAL PCB FEMALE CONNECTOR
90147-1114	1	J3	MOLEX	14 PIN SINGLE ROW VERTICAL PCB FEMALE CONNECTOR
B3S-1002	4	SW1-SW4	OMRON	Momentary Pushbutton Tactile SMT Switch
BAT54A	7	D1-D7	DIODES	30V SCHOTTKY DIODE
CSTCE12M5G55	1	U3	MURATA	Piezoelectric Resonator
GRM21BR71C475KA73L	4	C1, C3-C5	MURATA	CERAMIC CAP
H1045-00103-50V10	1	C2	GENERIC	Multilayer Cap
H2511-01001-1/16W1	4	R5, R7, R9, R11	GENERIC	Thick Film Chip Resistor
H2511-01002-1/16W1	5	R3, R6, R8, R10, R12	GENERIC	Thick Film Chip Resistor
H2511-02001-1/16W1	1	R4	GENERIC	Thick Film Chip Resistor
H2511-04700-1/16W1	1	R2	GENERIC	Thick Film Chip Resistor
MCR03EZPF4701	1	R1	ROHM	COMPACT THICK FILM CHIP RESISTOR
PIC18F2431S0	1	U1	Microchip	Flash Microcontroller
SD04H0SK	2	SW5, SW6	C&K	SD Series Low Profile DIP Switch 4 Pos SPST
TSW-102-07-L-S	1	J4	SAMTEC	2 Pin Header 2.54mm (.100) Pitch

Schematic, Daughter Card (controller)

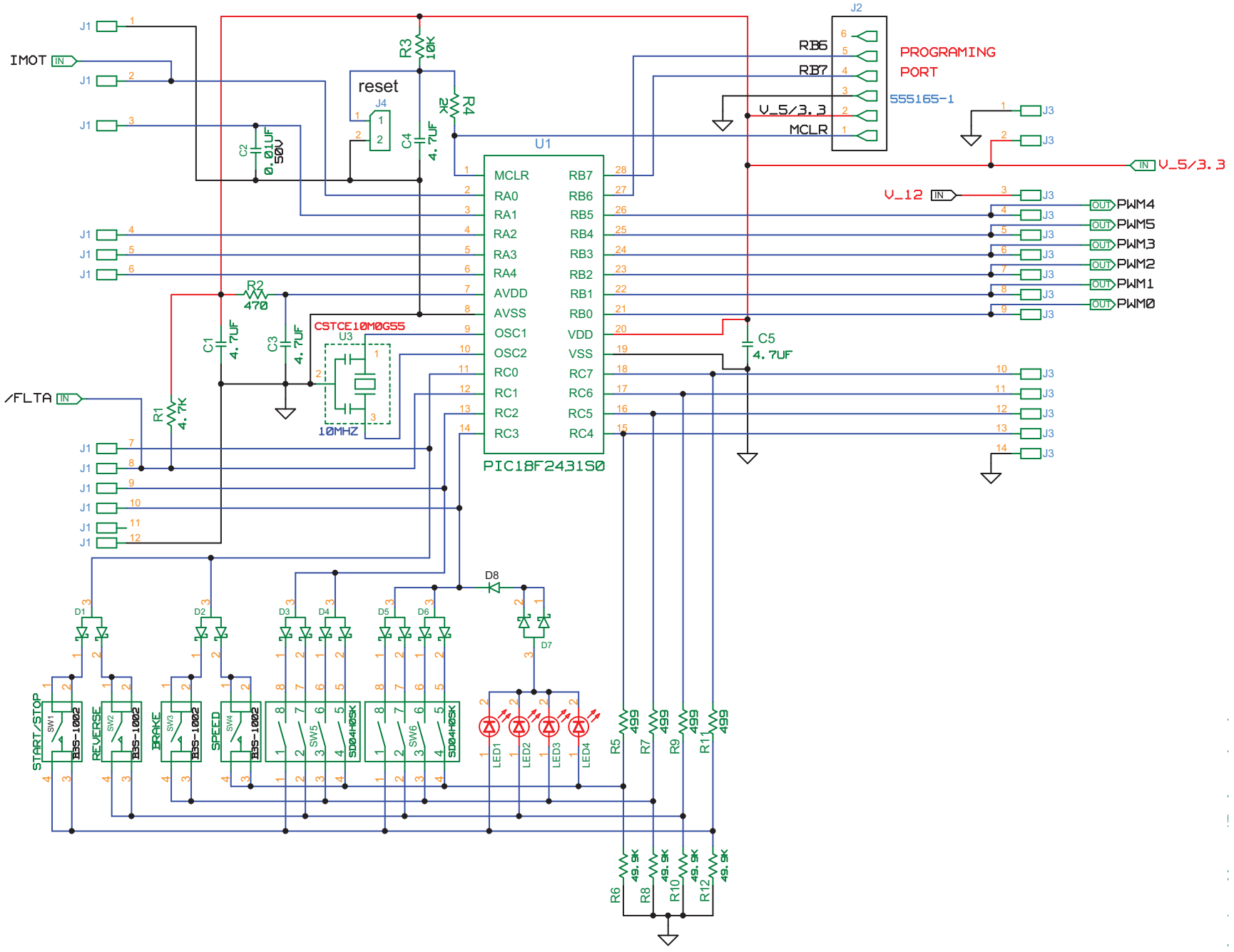

Schematic, Mother Board (Controller Socket)

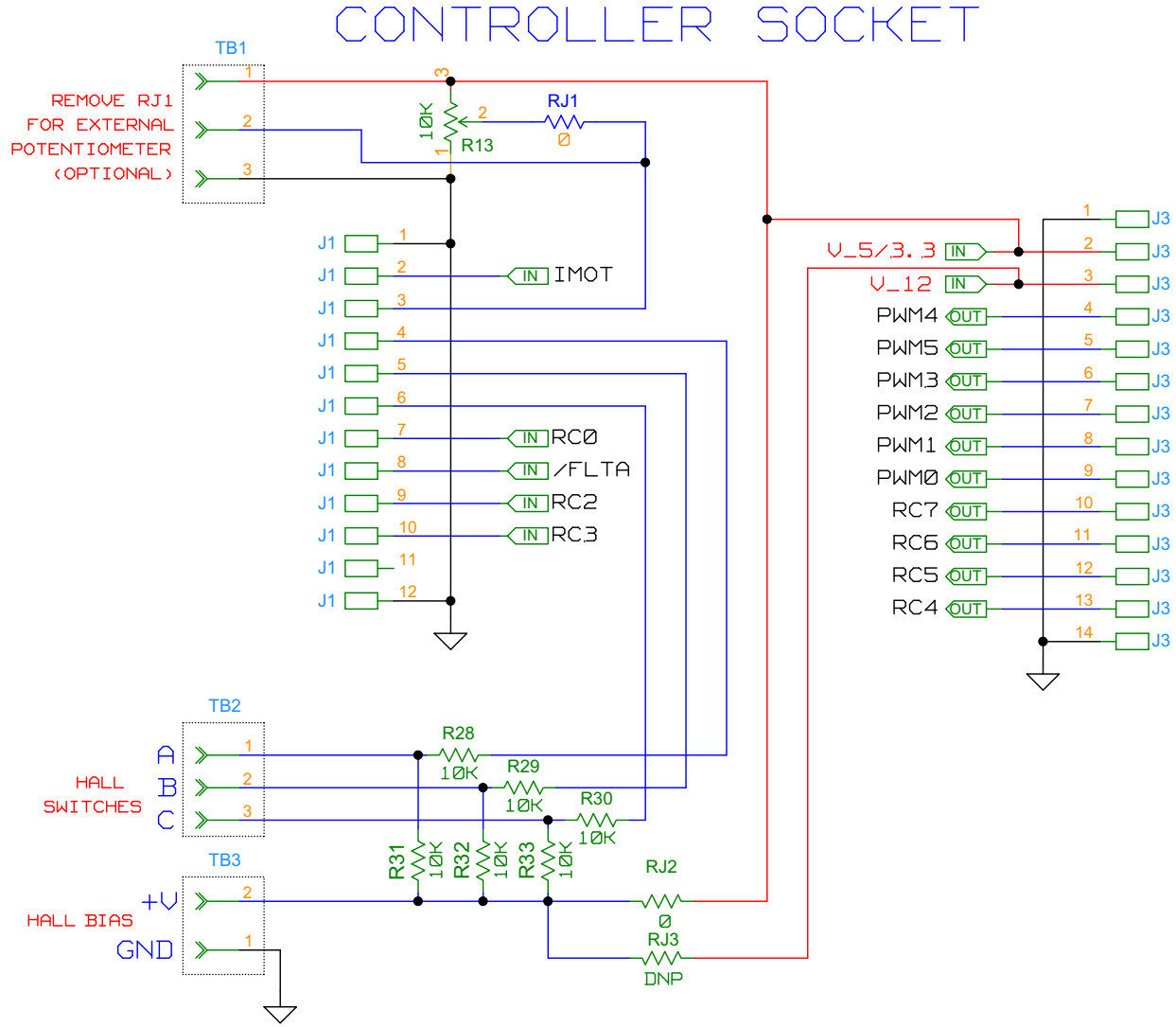

Schematic, Mother board (Bridge and Current Sense)

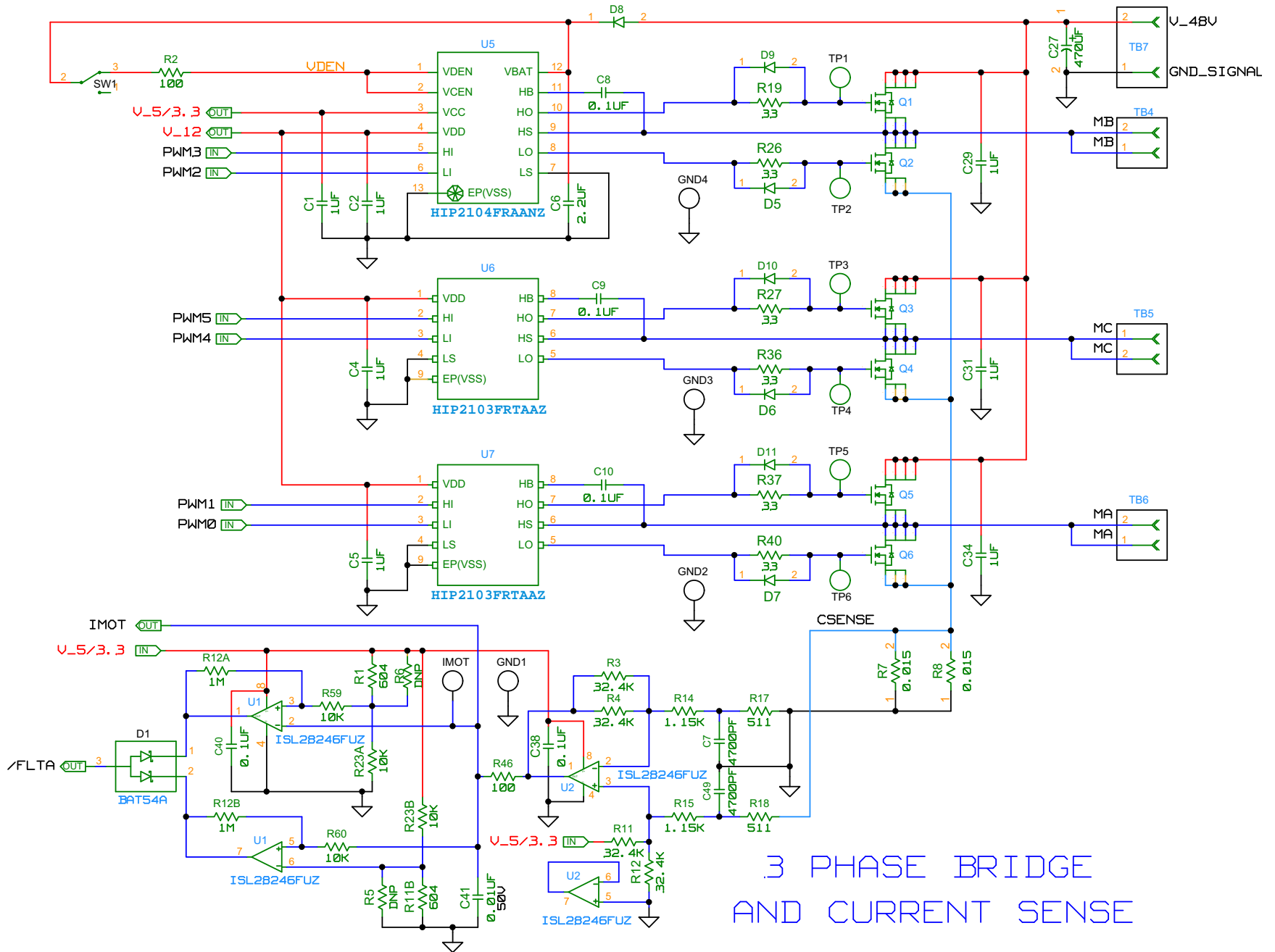

3 PHASE BRIDGE
AND CURRENT SENSE

Silkscreen, Mother Board

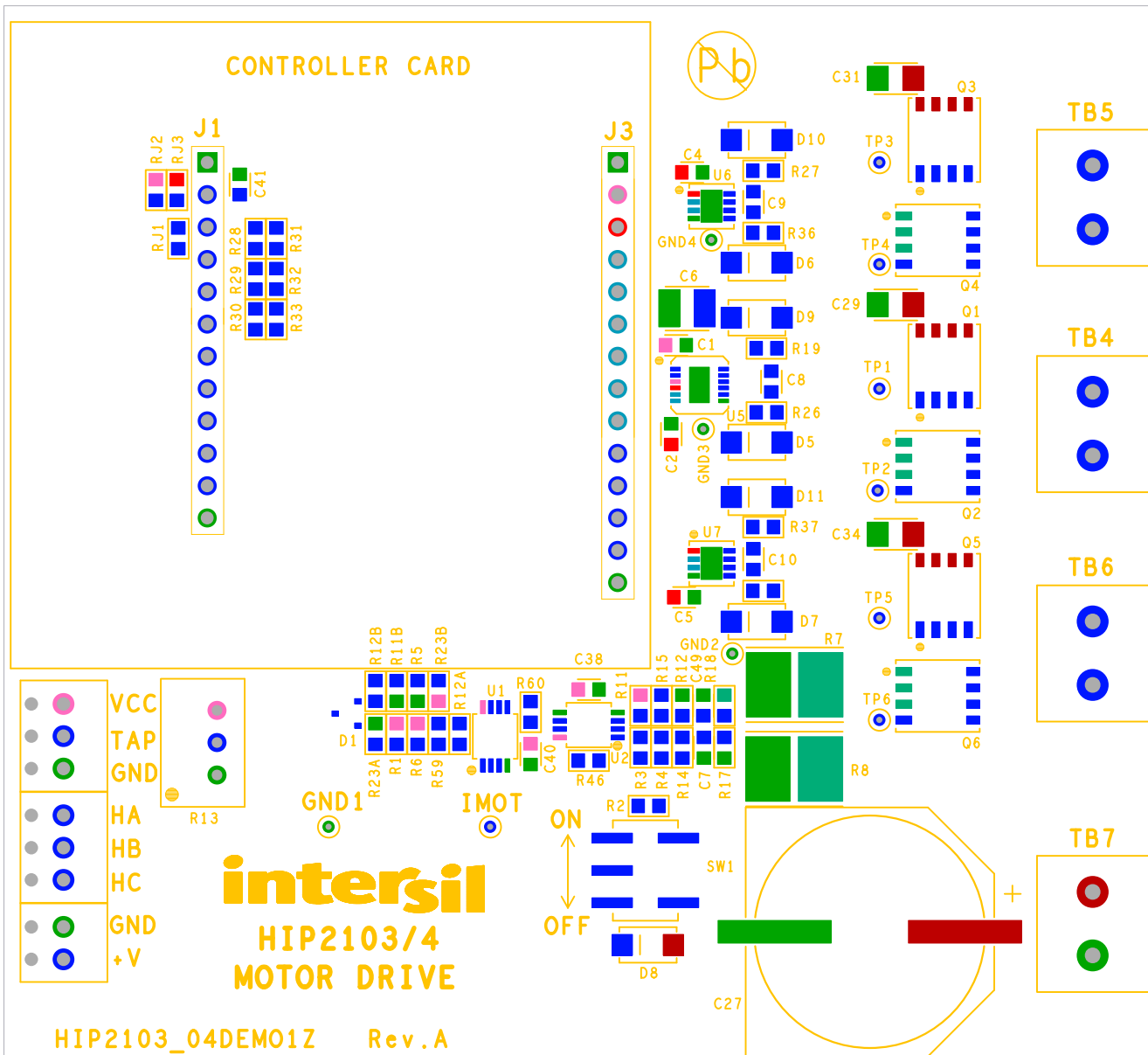

FIGURE 14. LAYER 1

PCB, Mother Board

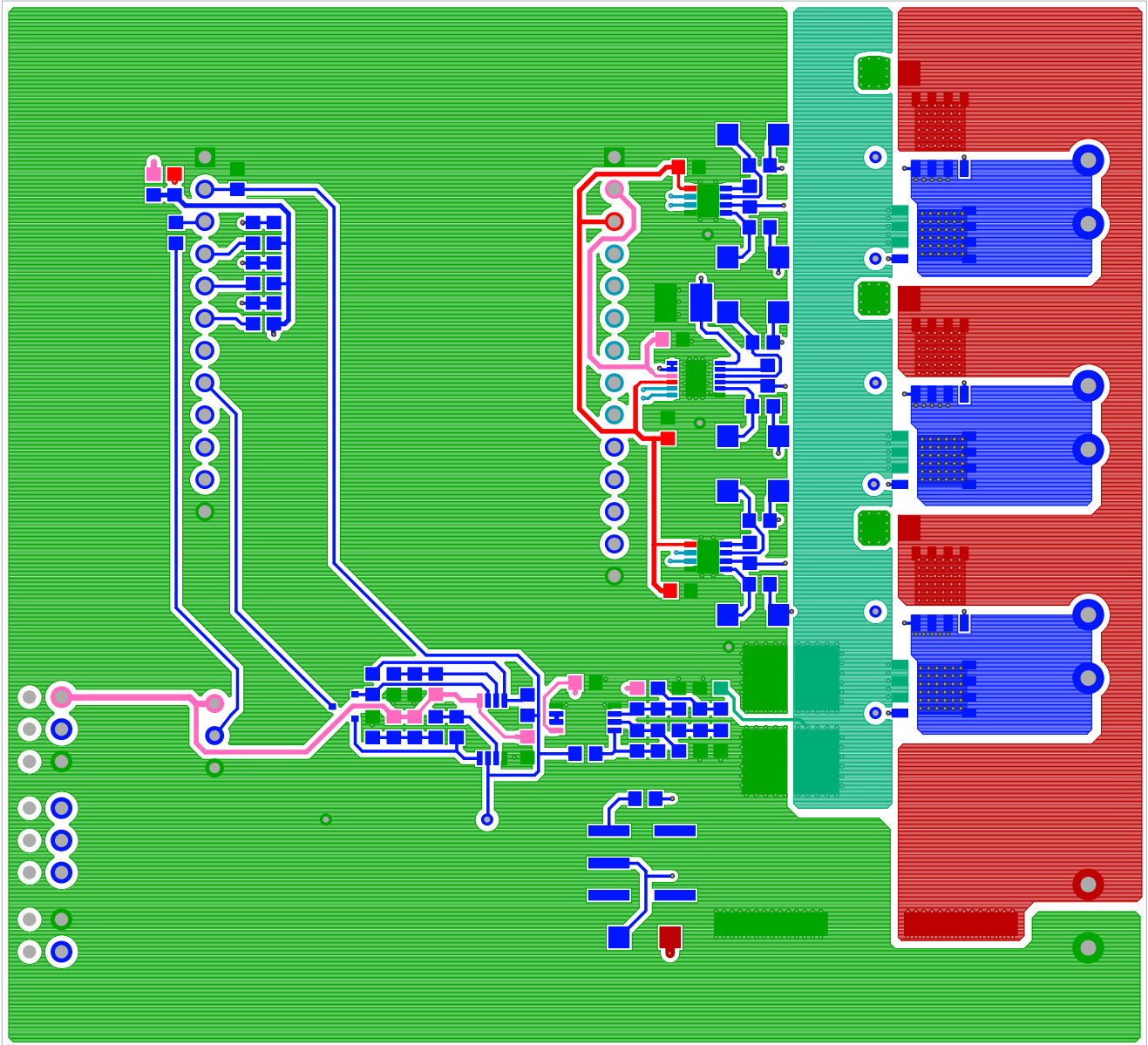

FIGURE 15. TOP LAYER

PCB, Mother Board (Continued)

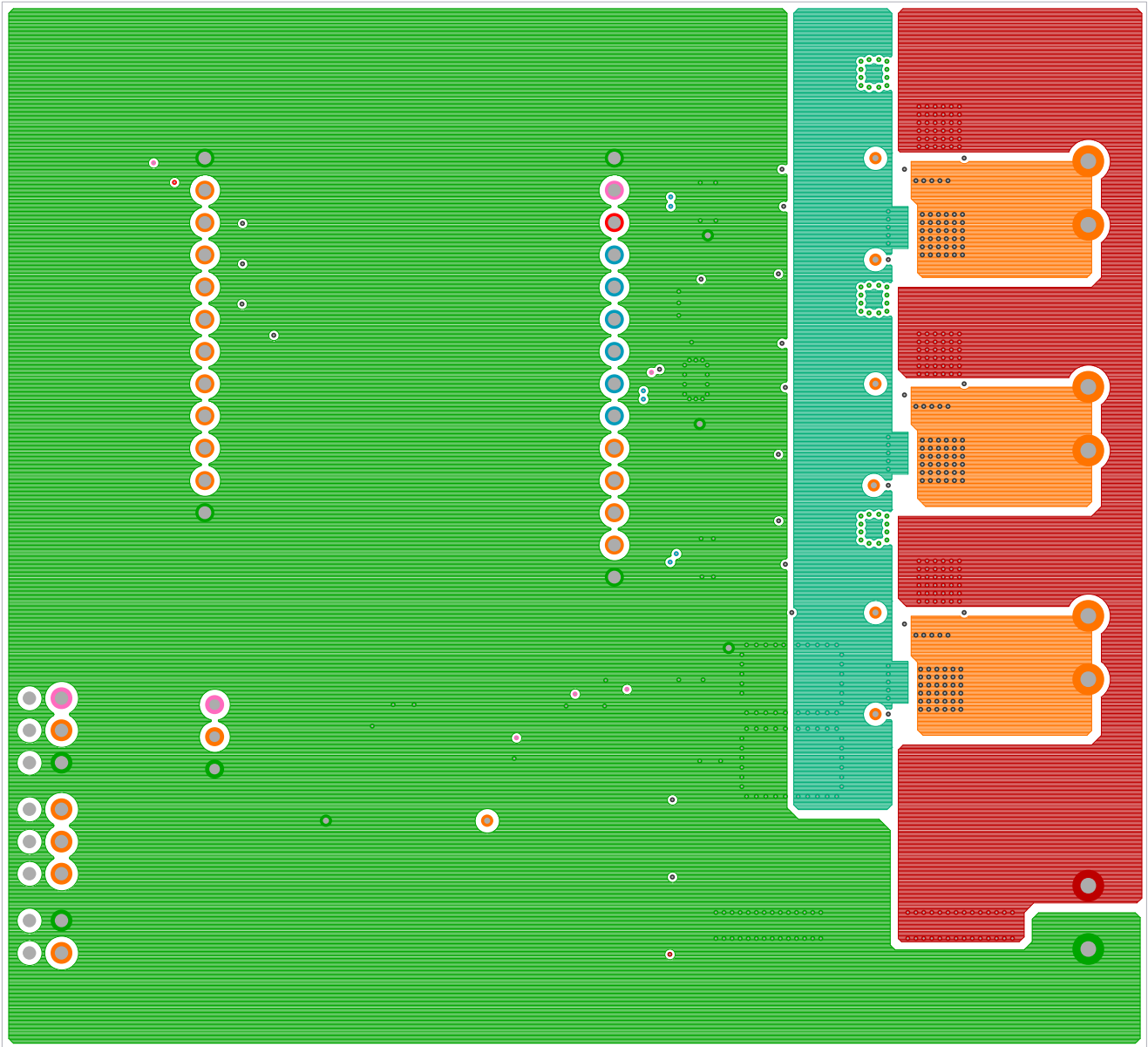

FIGURE 16. LAYER 2

PCB, Mother Board (Continued)

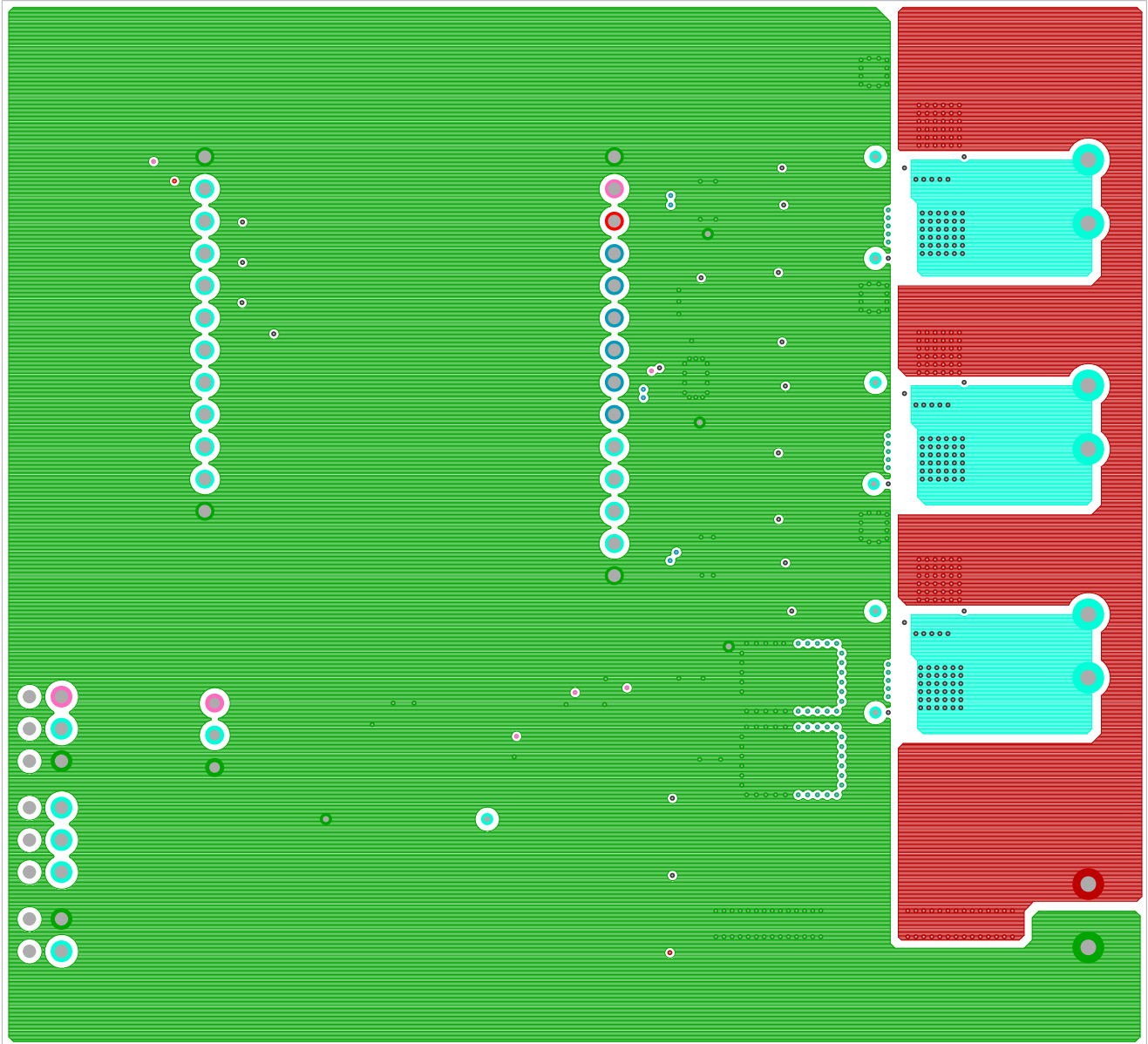

FIGURE 17. LAYER 3

PCB, Mother Board (Continued)

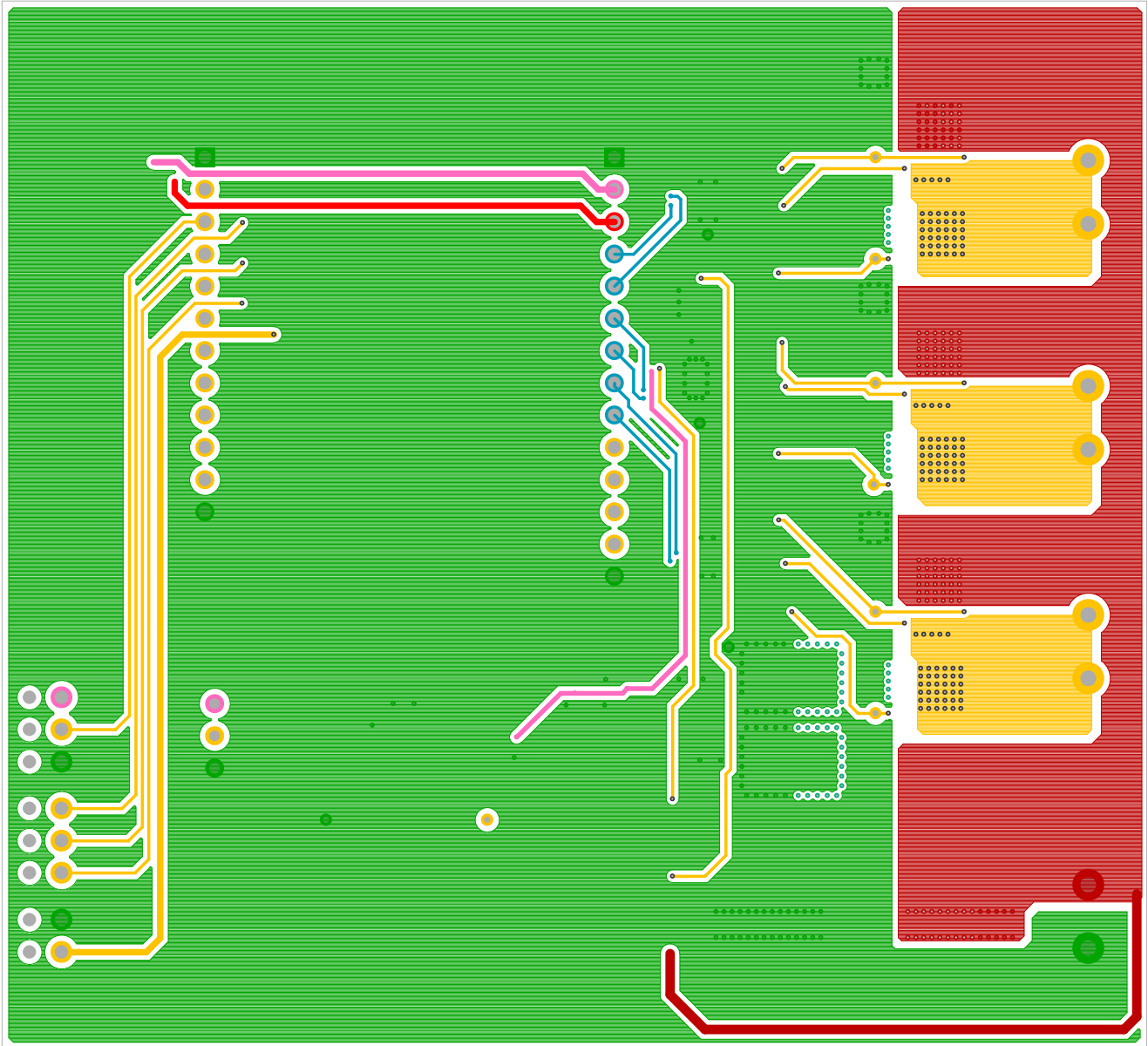

FIGURE 18. BOTTOM LAYER

Silkscreen, Control Card

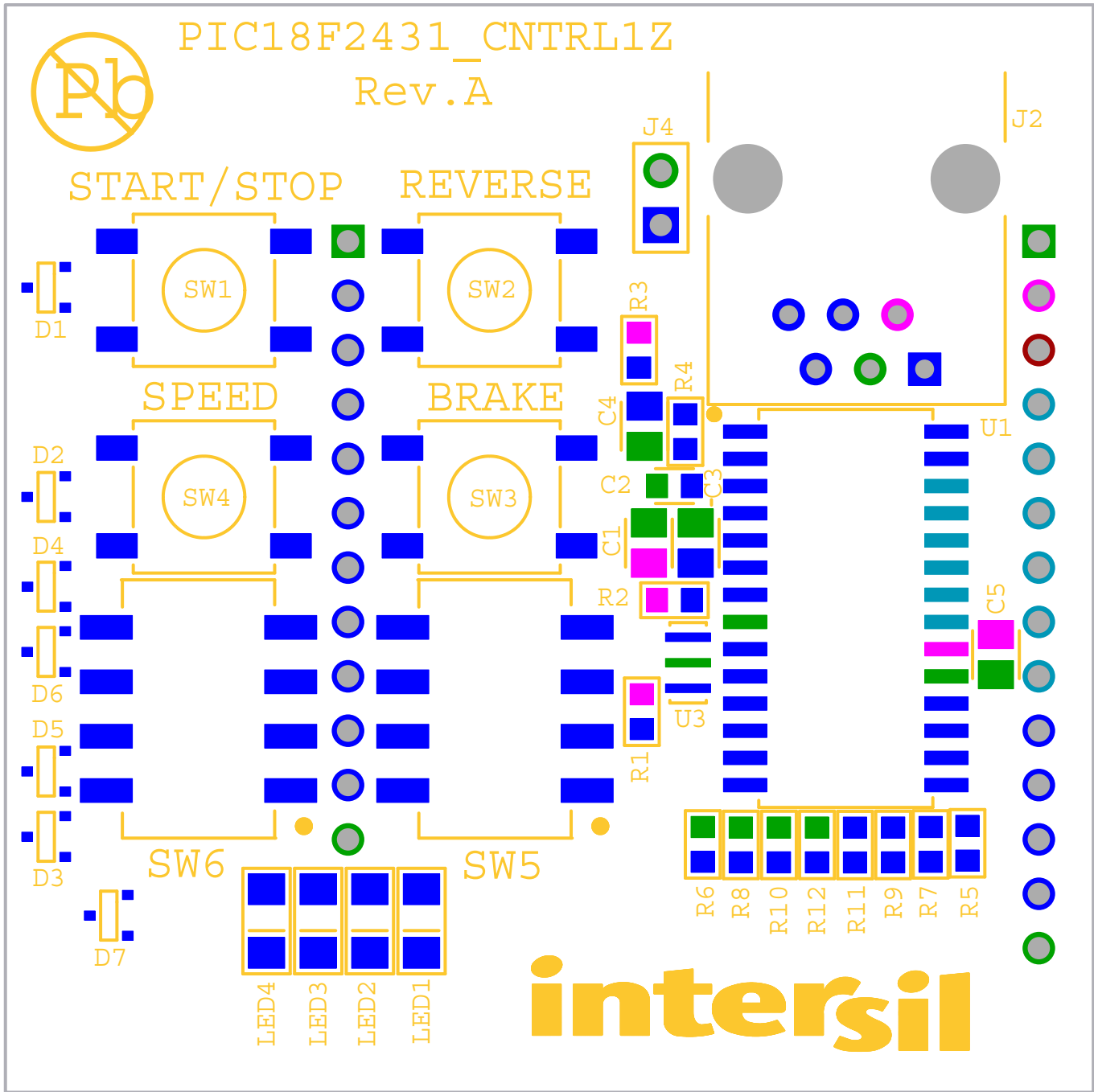

FIGURE 19. SILKSCREEN

PCB, Control Card

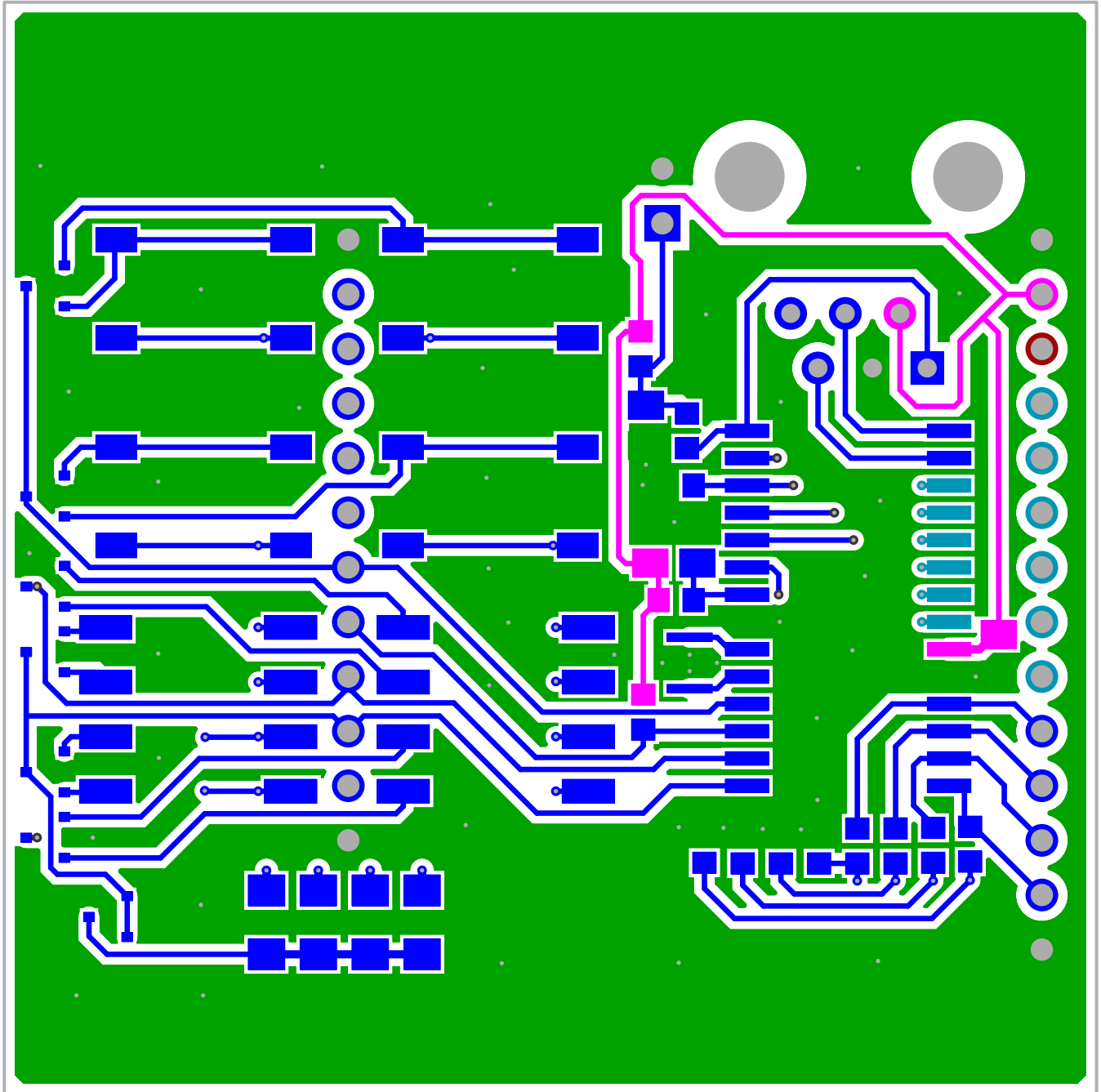

FIGURE 20. TOP LAYER

PCB, Control Card (Continued)

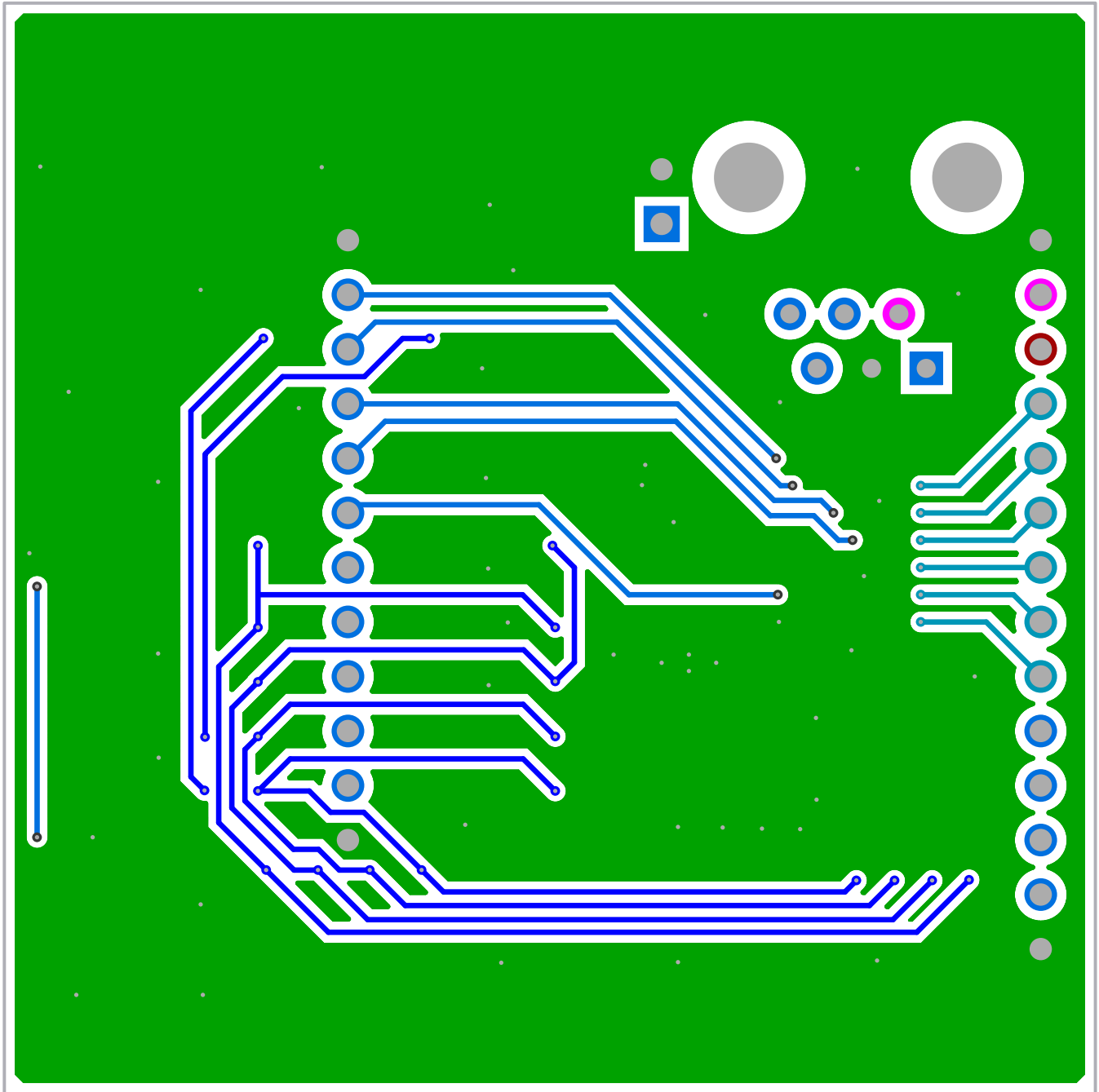

FIGURE 21. BOTTOM LAYER

Intersil Corporation reserves the right to make changes in circuit design, software and/or specifications at any time without notice. Accordingly, the reader is cautioned to verify that the Application Note or Technical Brief is current before proceeding.

For information regarding Intersil Corporation and its products, see www.intersil.com

Mouser Electronics

Authorized Distributor

Click to View Pricing, Inventory, Delivery & Lifecycle Information:

[Intersil:](#)

[HIP2103-4DEMO1Z](#)