

Experiment 5

System PCB Layout

ECE 482

The objectives of this experiment are:

- To gain experience with best practices of PCB layout including digital, analog, and power circuitry
- To use knowledge develop in Experiments 1-4 to formulate and implement system improvements

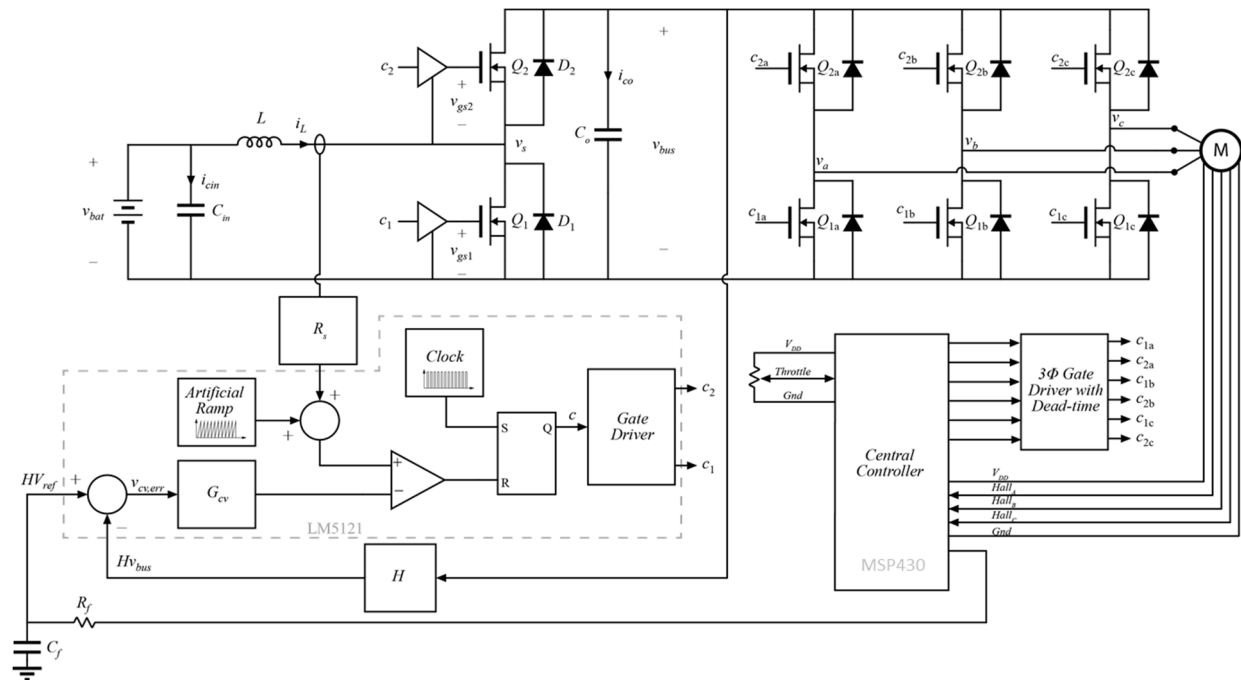

Figure 1: Example system diagram for drivetrain power conversion including DC-DC boost, motor driver, and central controller

In this lab, you will use Altium Designer to create a two- or four-layer printed circuit board which implements your electric vehicle drive train. This will include both the DC-DC boost converter which you have previously constructed in experiments 3 and 4, as well as the motor driver.

I. Design Finalization

Working as a group, finalize design decisions which will define your system. This includes the use of GaN devices, redesigning the boost power stage, selecting motor drive topology, and designing any additional circuitry per your prelab assignments.

Because we have time for only one PCB fabrication this semester, make sure to consider “backup plans” throughout the experiment as you perform PCB layout. As an example, if you have concluded that a PI compensator is sufficient for your boost converter, you may want to leave space for a more complex PID or similar compensator, which you do not intend to populate, but will have available in the event of an original design performing below your expectations.

You are free to alter the design of the boost convert and/or change control implementation. However, your system must be capable of boosting the battery voltage up to at least 50V, and must consider overcurrent, soft start, and inrush current protection.

If using GaN devices, consider implementing a two-board setup, where the power devices, gate driver, and relevant decoupling capacitors are on a separate PCB which is connected via board-to-board plugin connectors (as in the MSP430 breakout). This way multiple power stages can be swapped out in the event of a device failure. These will be fabricated as a single PCB, but can be cut apart in the mechanical shop. If this method is employed, make sure to consider connector parasitics.

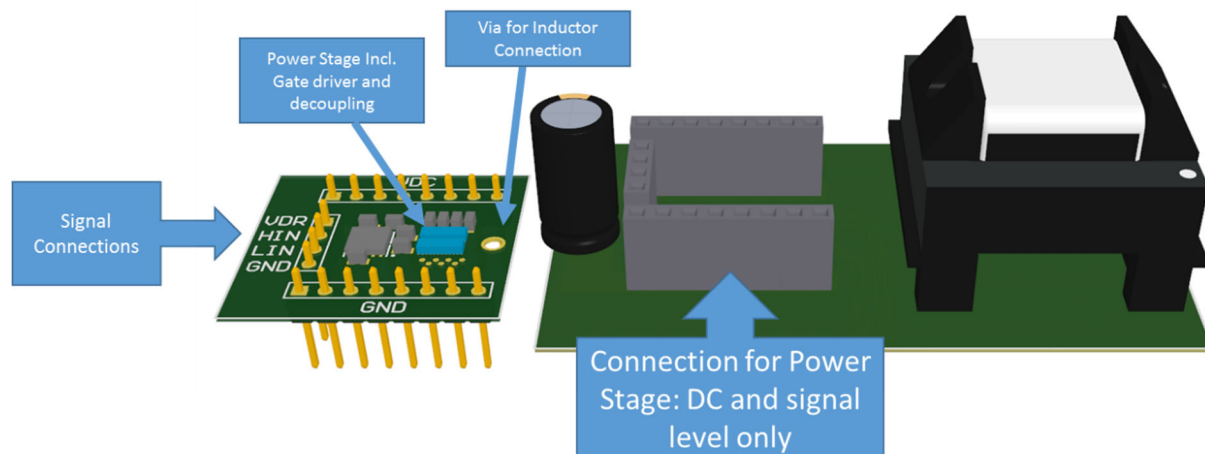

Figure 2: Conceptual example of power stage daughter board. Note that, because the connectors will have L - C - R parasitics, only DC and signal-level connections are made from board-to-board

II. PCB layout

Read through the materials on Altium Designer on the course website linked from the experiment 5 page. The PCBs ordered will be “no-touch”, standard specification boards from Sierra Circuits. A design rule file to include these specifications in Altium Designer has been posted on this page.

Additionally, PCB footprint and schematic libraries and a starter project for the experiment are provided. These files contain information on many of the parts included in the nominal system, and start with a nominal schematic. You will need to alter these and make additional

connections; use these as a starting point for your PCB design. As you select new components for this lab, include the schematic symbols and PCB footprints that you create in these libraries for better organization. **Do not** rely on the connections, footprints, or design in these starter files without reviewing to ensure they meet your needs and the components are *currently* in stock.

III. Motor Driver Implementation

The motor driver must consist of a three phase inverter with each leg comprised by a transistor half-bridge. Additionally, relevant high- and low-side transistor drivers should be selected so that the devices may be switched on and off. Your driver circuit implementation must be capable of switching each half bridge into one of three states. The states are given in Table I; the circuit must be able to hold each half bridge independently in any one of the three states for an arbitrary time (i.e. an adjustable dead time alone is not sufficient to implement State 0).

TABLE I: HALF BRIDGE STATES IN DRIVE TRAIN INVERTER

State	High Side Device	Low side Device
0	Off	Off
1	Off	On
2	On	Off

In the starter files, three example motor drive implementations are given. You may select to start your design from one of these three, or change it entirely.

Additionally, you must have the ability to regulate the DC input current into the motor drive in closed-loop, in response to the throttle voltage. Depending on the selection of power stage and motor drive control, this can be an analog or digital loop, and can be CPM or averaged current mode control. This loop should have bandwidth fast enough to track the throttle, but well below the motor drive electrical frequency during motoring.

IV. Circuit Connections and Protection

Figs. 3 and 4 detail the electric bicycle platform to which you will attach your completed power converter drivetrain PCB, as well as the included circuit protection devices.

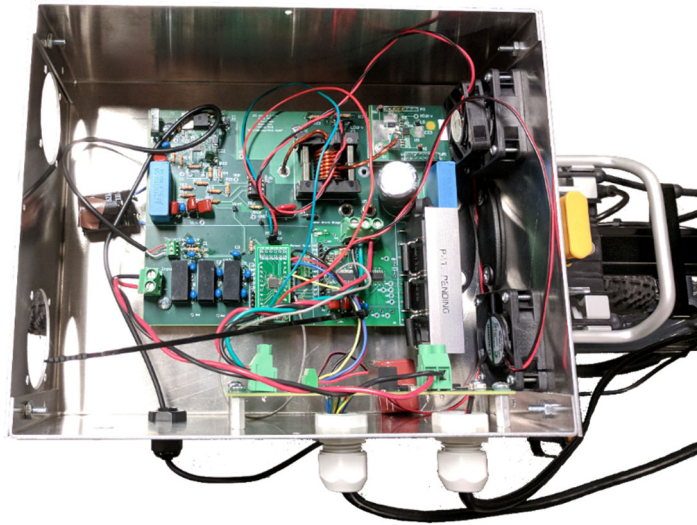

Figure 3: Circuit enclosure and protection board (example student PCB included)

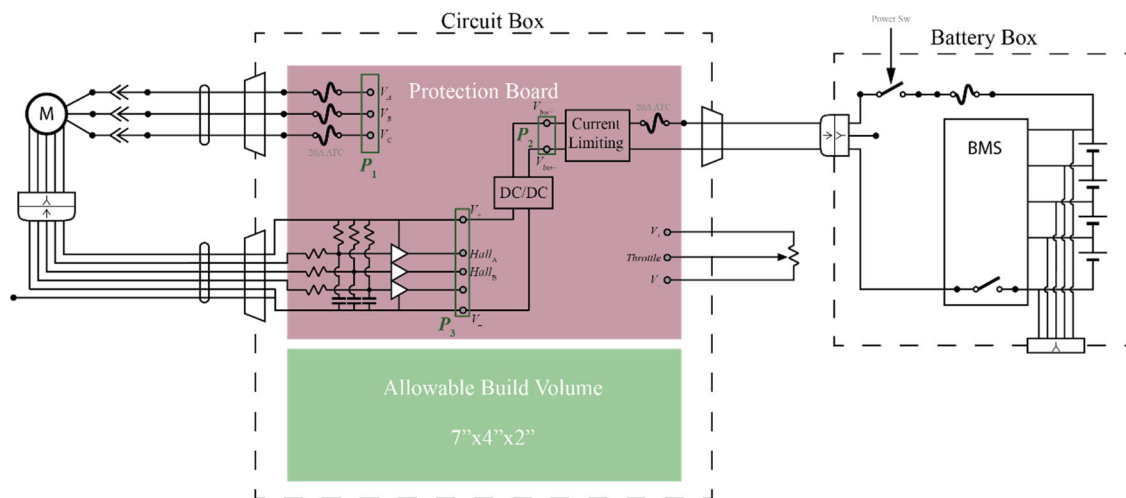

Figure 4: Included circuit protection and connections diagram

Note that protections are included to prevent damage to the motors. Your circuit will not connect directly to the motor, but will instead connect to the protection board, through connectors P_1 , P_2 , and P_3 . All relevant screw-type connectors are included in the Altium starter files.

Note that the hall sensors are powered by a dc-dc mounted on the protection board, and already have pull-up resistors and buffer elements. You should not attempt to power the V_+ pin of the hall sensor connector, P_3 , but will need to connect the V_- pin to your circuit ground.

Your PCB should stick to the board size defined by the starter files in order to fit within the build space in the circuit box. Six holes are included for mounting to the included standoffs. You will not have access to the Battery Box.

Auxiliary Supplies

To allow the electric bicycle to be a fully contained system, all components must obtain power from the battery pack itself. A pair of RSO-24xxS isolated power supplies are included in the starter templates as examples. These supplies are available with outputs of 3.3, 5, 9, 12, and 15 V with a common footprint. Depending on your design, you may be able to operate without these, may require additional supplies, or may want to use alternate parts.

V. Bill of Materials

You must use the integrated supplier search functionality of Altium Designer (View > Workspace Panels > System > Supplier Search) to keep track of a bill of materials for your order. When completed, your Altium project should have supplier references for all parts which are not either in your possession currently, or which you plan to purchase from the parts store.

For all parts that the teams are requesting to be ordered, teams must submit immediately actionable resources for ordering. For vendors including Digikey and Mouser, this can be achieved by links to carts. For other vendors, quote documentation with ordering information will suffice. You may spend up to **\$350** on components and PCB for this experiment. Reuse components from the first four experiments where reasonable. You will not receive *any* additional components other than what you order as part of this experiment

VI. Design Completion

All circuit boards will be ordered with Sierra Circuits' NoTouch, 4-layer specifications. Details are given at <https://www.protoexpress.com/NoTouch-pcb/product-specs.jsp>, except as specified below. Each group will receive two (2) copies of their PCB layout. Prior to submission, each layout must successfully pass the AFV check here: <https://www.protoexpress.com/orderProc/noTouchNew.jsp>, with no issues found. The quote should be specified with

- 4-day turn
- 5 mil minimum trace/space
- 15 mil hole size
- 2 board quantity
- (up to) 4 layers

Note: Sierra Circuits' AFV process may be unable to complete outside of business hours if the board has issues that cannot be resolved in an automated manner. Plan to complete your layout well before the deadline to ensure that an error-free AFV can be submitted before the deadline. You should also consider intermediate submissions, even if layout isn't complete, to make sure your partially-completed structures are valid.

Teams must submit, via canvas, one .zip archive of the completed PCB layout. The layout must successfully pass Sierra Circuits' AFV check prior to submission. The zip archive should contain the following file types from the Altium project:

1. PrjPcb
2. SchDoc

- | | |
|-----------|-----------|
| 3. SchLib | 5. PcbDoc |
| 4. PcbLib | 6. BOM |

In your submission include your username and password (make sure to change your password to something not used for any other personal account) to the Sierra Circuits webpage. Prior to submission, move all quotes *except* the one final board which has passed AFV to your old/hidden folder.

VII. Deliverables

You will not complete a lab report for this experiment. Instead, you will turn in, by e-mail, the following:

1. Direct, actionable purchasing links/materials for all components
2. Sierra Circuits login information to your account, with **only** your final design in the “Main Folder” of the No Touch / AFV Status Page
3. Final .zip file of all gerber and NC drill files which passed DFM, along with your board dimensions (in e-mail text).
4. A .zip file of your Altium project. Include only Schematics, Layout, Project file, Schematic and Footprint libraries, and BOM
5. A short summary of redesign you have made relative to your Experiment 2-4 converter, including calculations justifying the changes (replaces prelab)

grade for this lab will be based on the timely completion of a manufacturable PCB layout which exhibits good layout practices, as discussed in lectures/notes, and proper implementation of system modification resulting from your experience in Experiments 2-4.