

Analysis of a switched capacitor converter

The switched capacitor converter of Fig. 1 operates with large C_{out} such that V_{out} is nearly constant. All other capacitors have equal capacitance, $C_{1..7} = C_{fly}$. All MOSFETs have the same resistance, r_{on} . Devices are switched in two phases, such that all devices with gate signal g_1 are on during the first switching half-period, and all devices with gate signal g_2 are on for the other half of the period.

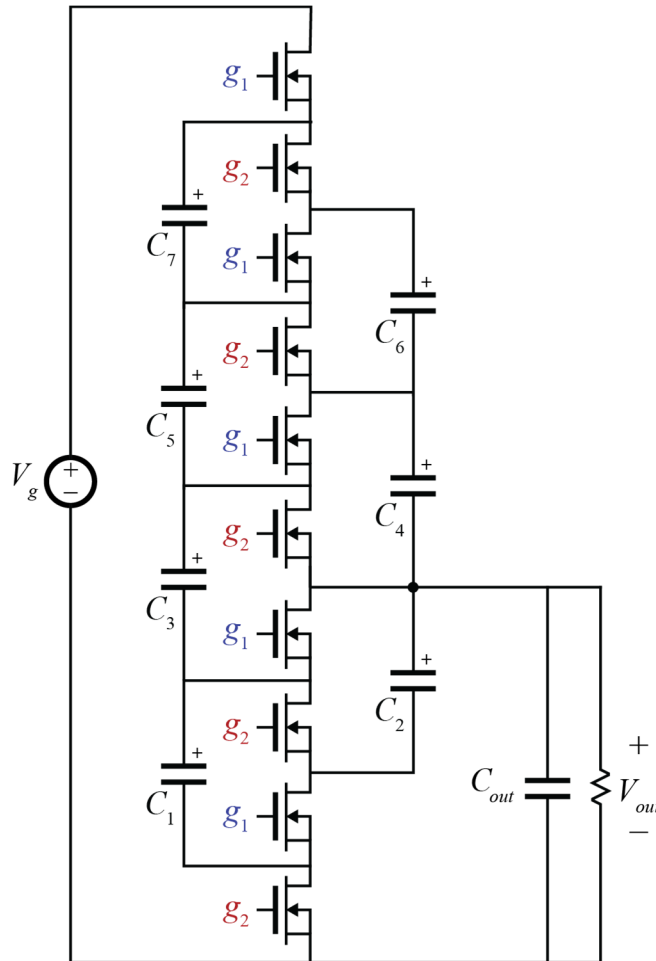

Fig. 1: Switched Capacitor Converter

Using any technique you deem appropriate, solve for

- The conversion ratio, $M = V_{out}/V_g$ when there is no output power
- The output resistance of the converter, $R_{o,SSL}$, when the converter operates in the SSL
- The output resistance of the converter, $R_{o,FSL}$, when the converter operates in the FSL