

State Plane Solution

Primary

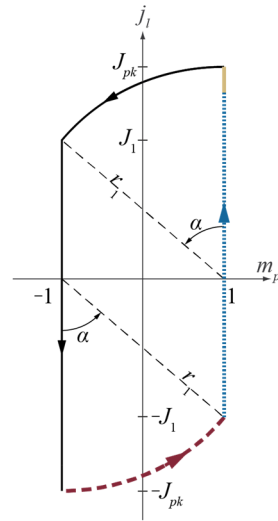

$$I_{base} = V_g \sqrt{\frac{C_p}{L_l}}$$

Secondary

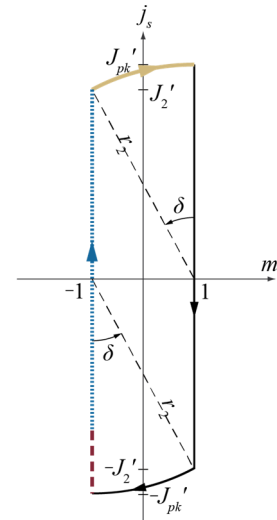

$$I_{base} = V_g \sqrt{\frac{C_s}{n_t^2 L_l}}$$

Averaging Step

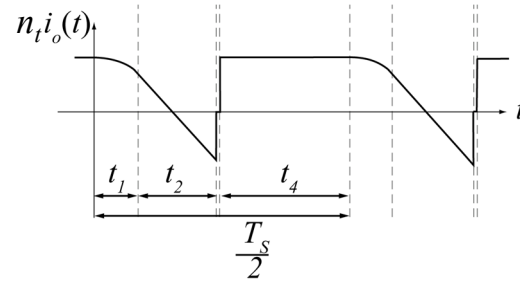

Output Plane

$$J = \frac{n\langle i_{out} \rangle}{I_{base}} = \frac{F}{\pi} \left[2 + \frac{1}{4} (J_1^2 - J_2^2) + J_p \left(\frac{\pi}{F} - \alpha - \theta_2 - \delta \right) \right]$$

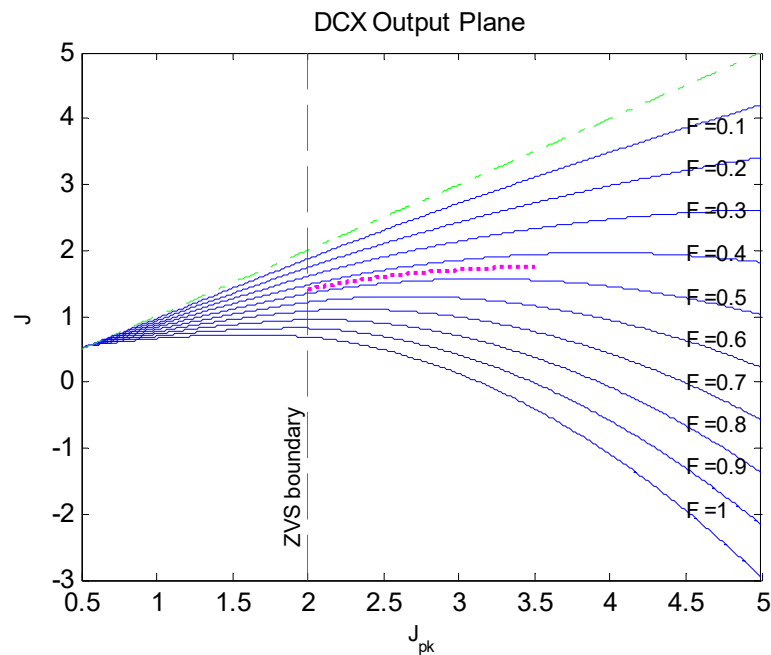

Example Waveforms

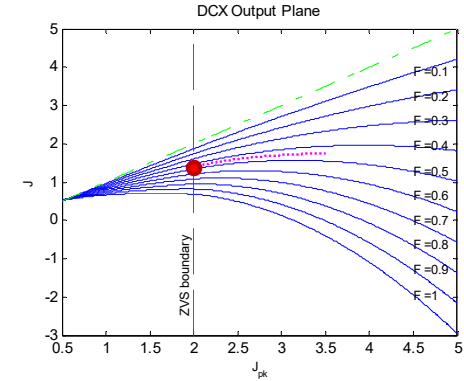
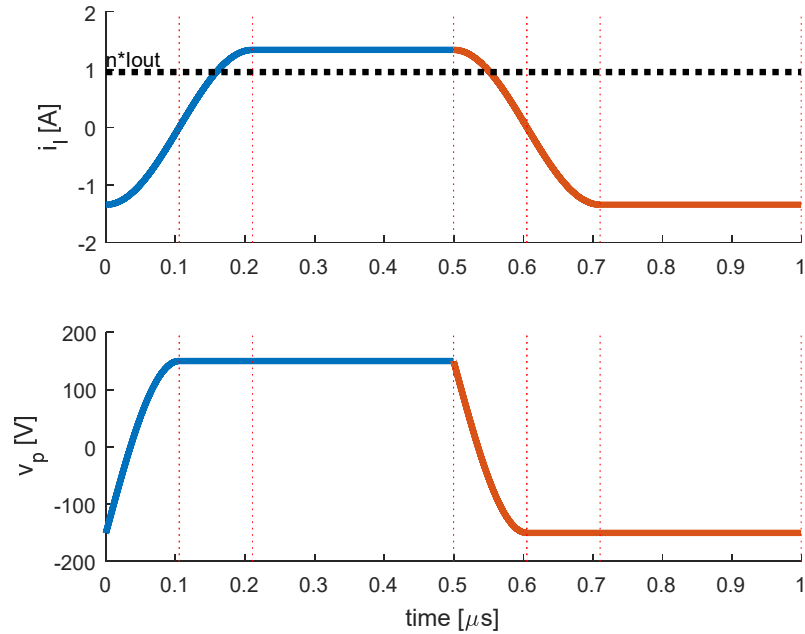

Example Waveforms

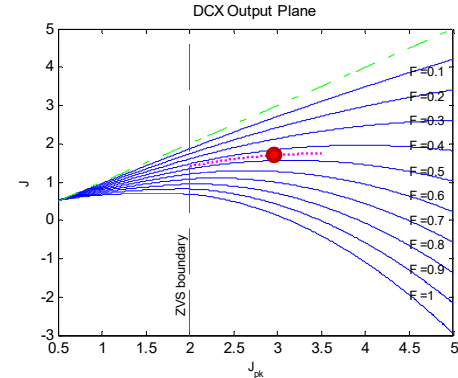
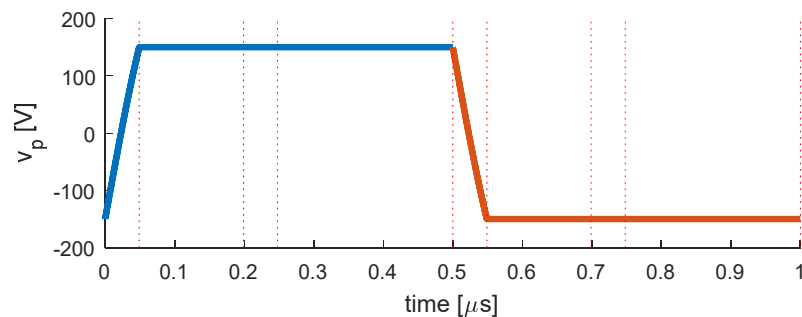
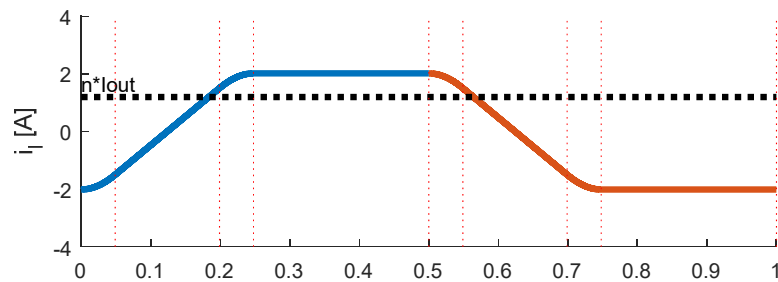

Example Waveforms

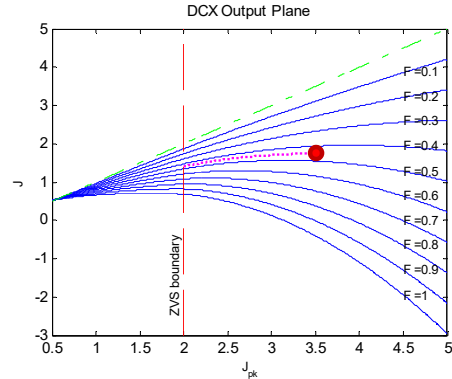
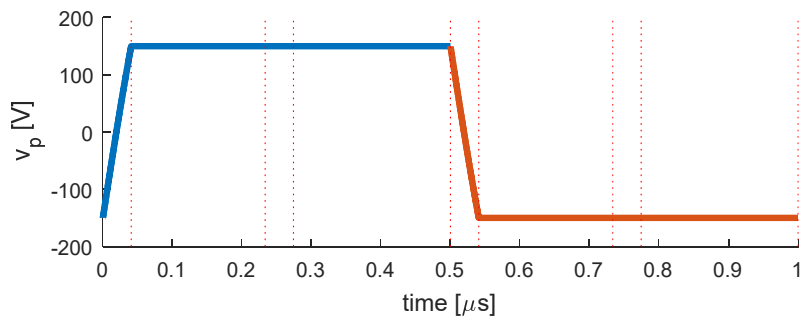
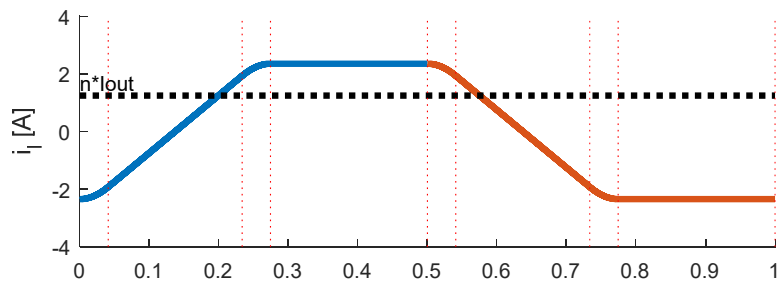

Example Waveforms

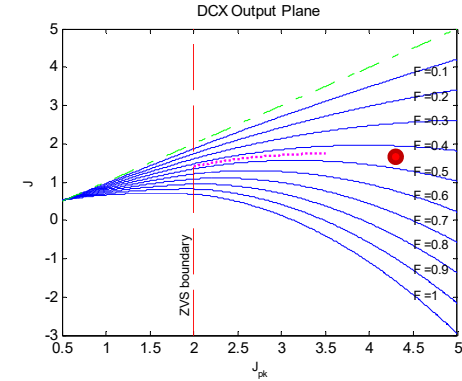
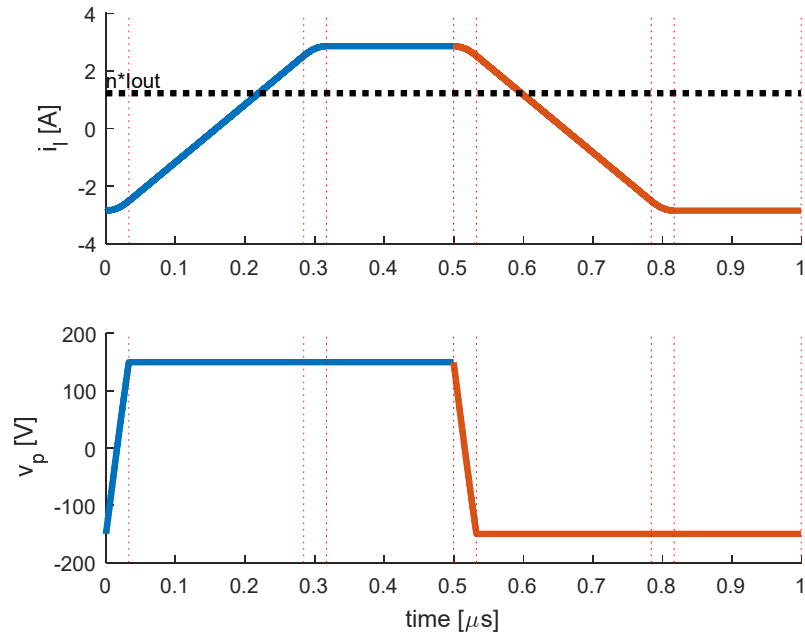

Example Waveforms

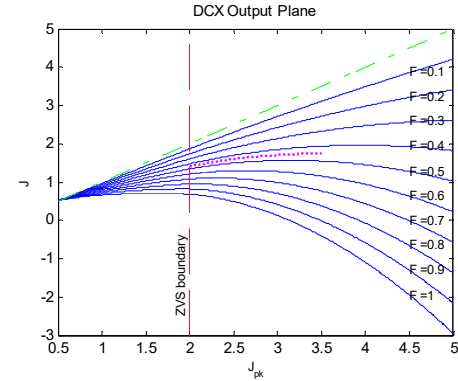
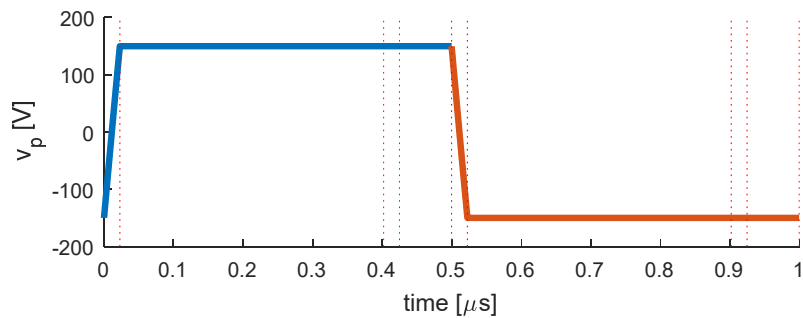
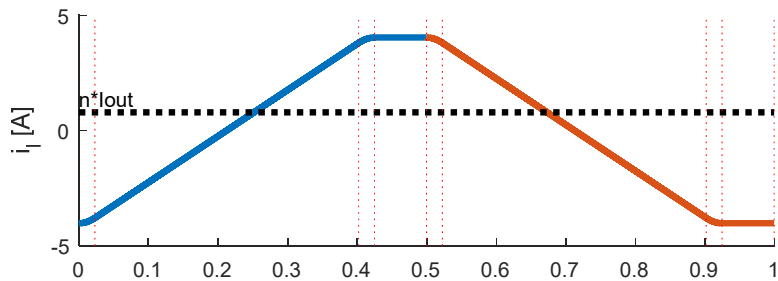

Output Current Vs. Inductance

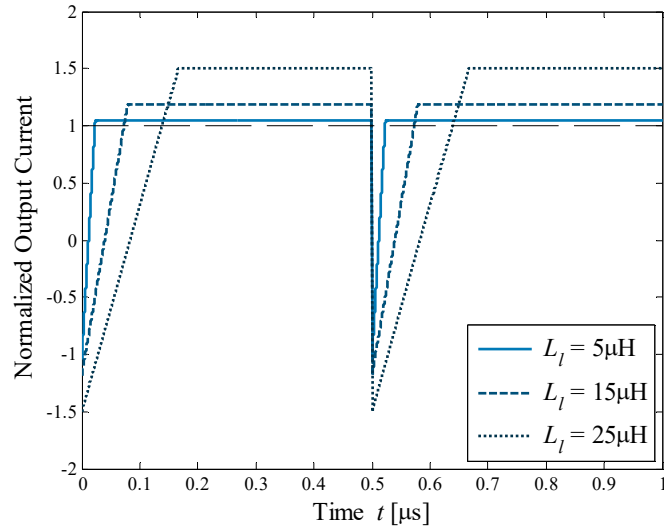

Output Current Vs. Inductance

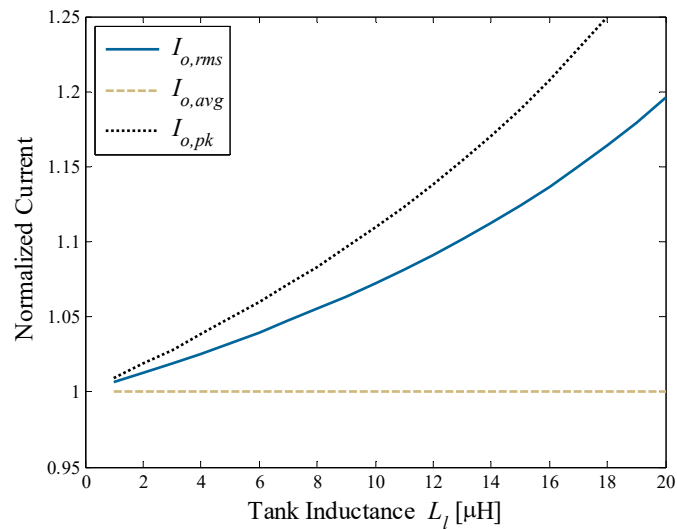
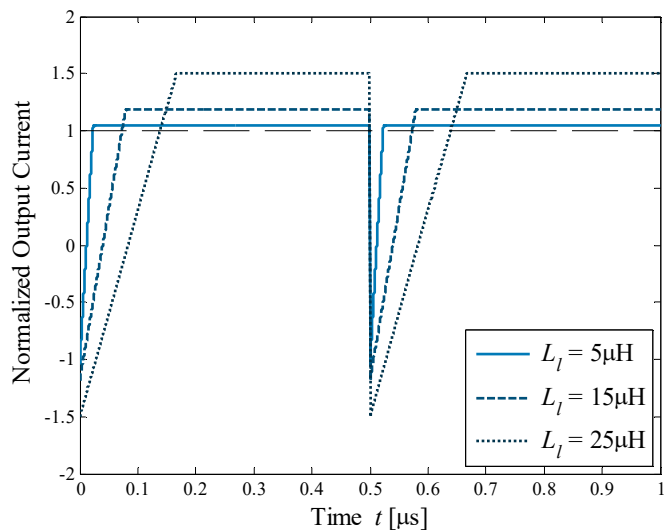

Constraints on Inductance

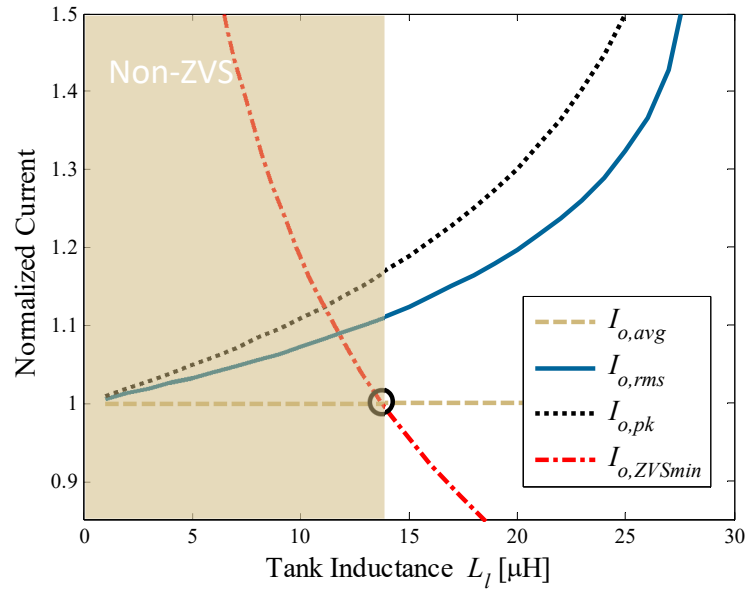

DAB: Experimental Results

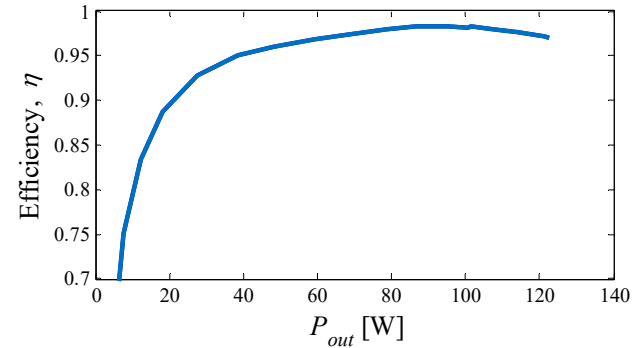
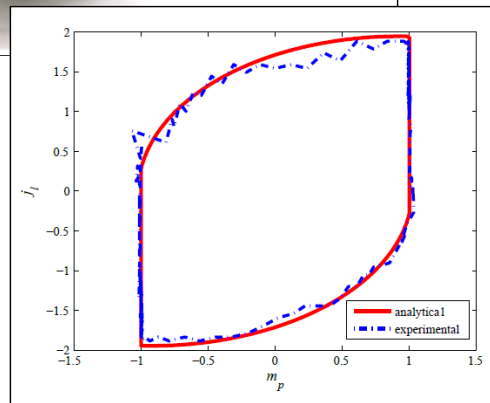
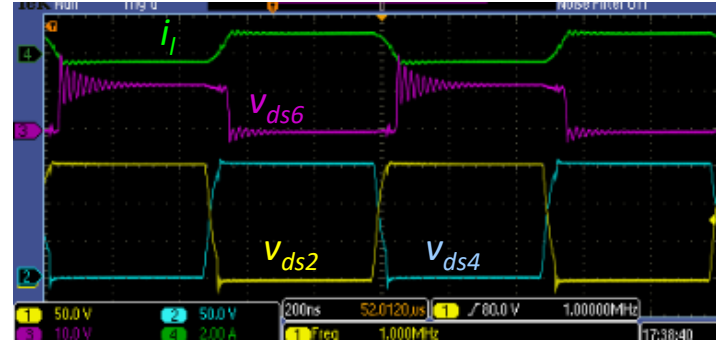
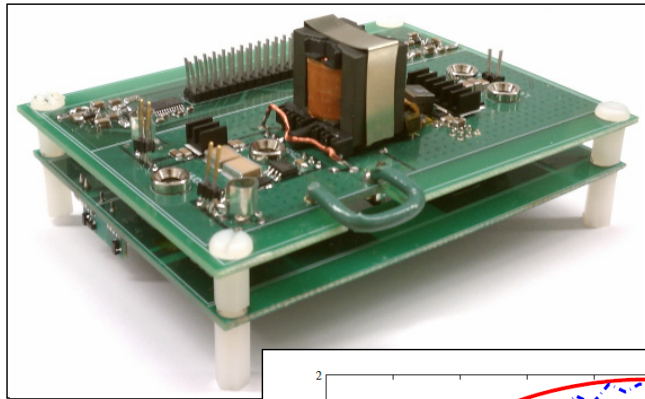

Operation with $V \neq nV_g$

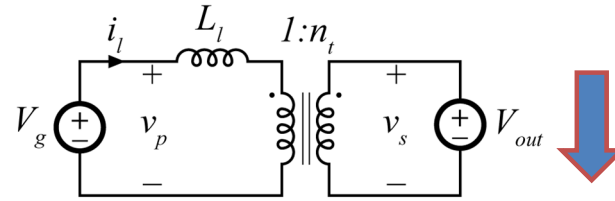
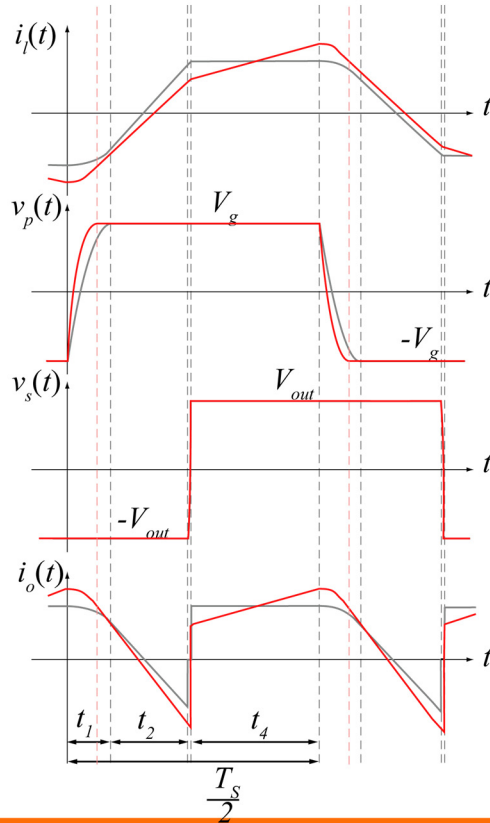

- E.g. Decrease to $M_N < 1$ by decreasing output voltage
- Current now ramping, causing more energy available for primary ZVS, but higher RMS currents
- Can use behavior to extend ZVS range of one bridge

Soft Switching Range with Varying V_{out}

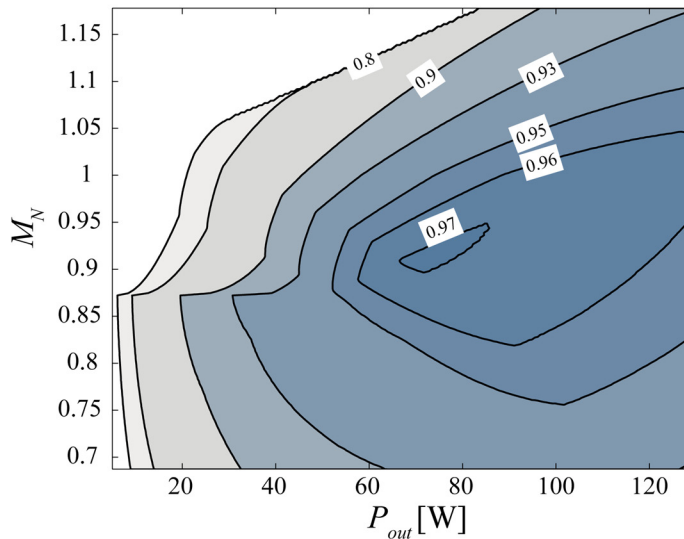
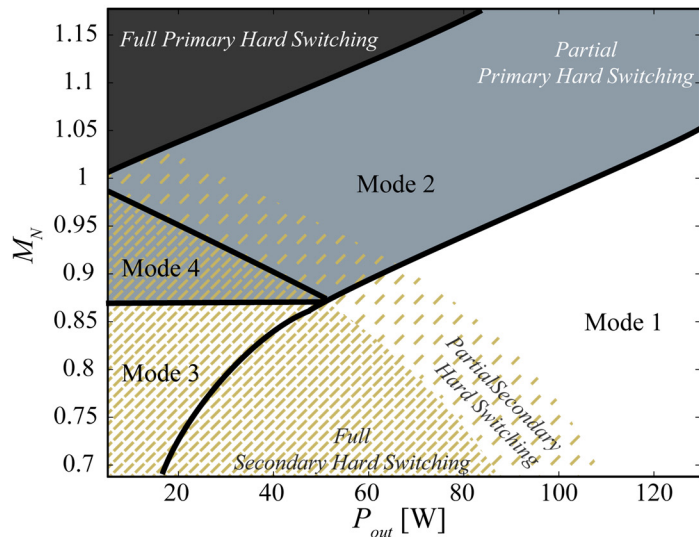

Application Example: Automotive

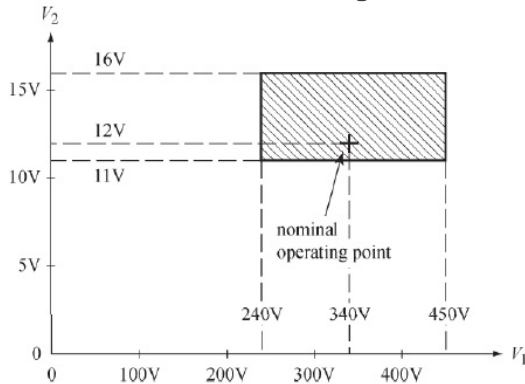

Fig. 1. Converter operating voltage ranges required for automotive application.

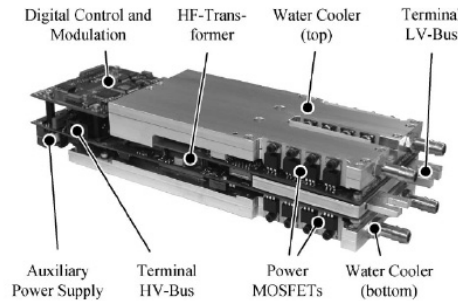

Fig. 3. Automotive DAB converter (273 × 90 × 53 mm).

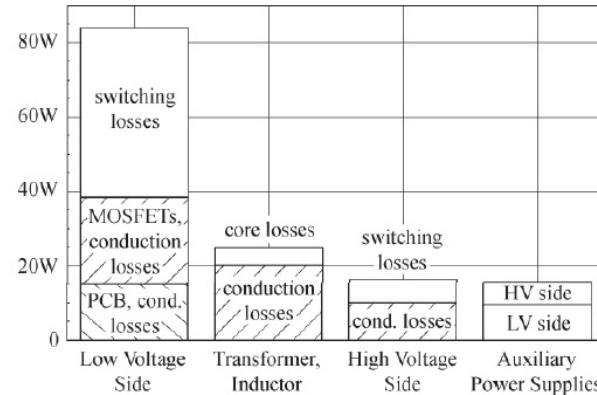
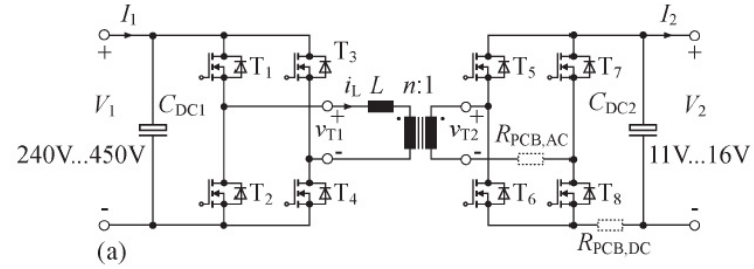
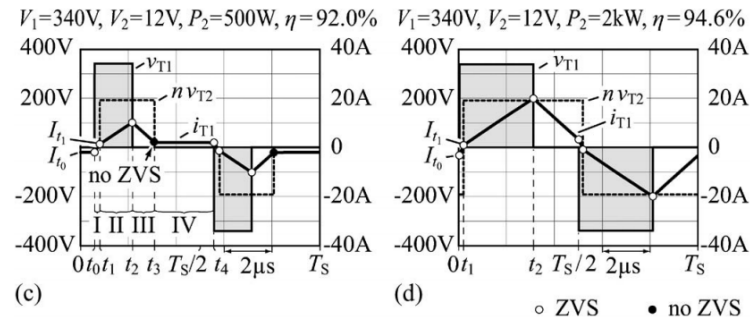
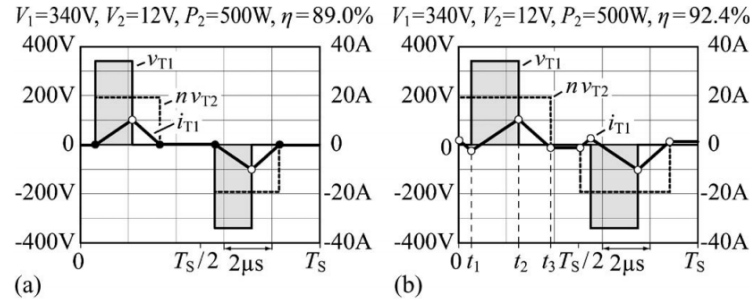
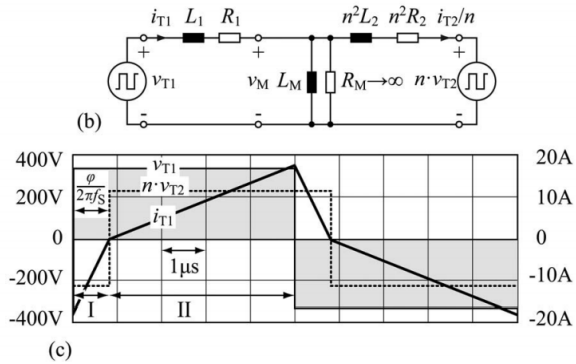

Fig. 13. Calculated distribution of the power losses for operation at $V_1 = 340$ V, $V_2 = 12$ V, and $P_2 = 2$ kW.

*F. Krismer, J.W.Kolar, "Accurate Power Loss Model Derivation of a High-Current Dual Active Bridge Converter for an Automotive Application, IEEE Trans. On Industrial Electronics, March 2010

Alternate Modulation Schemes



DAB: Transformer Saturation

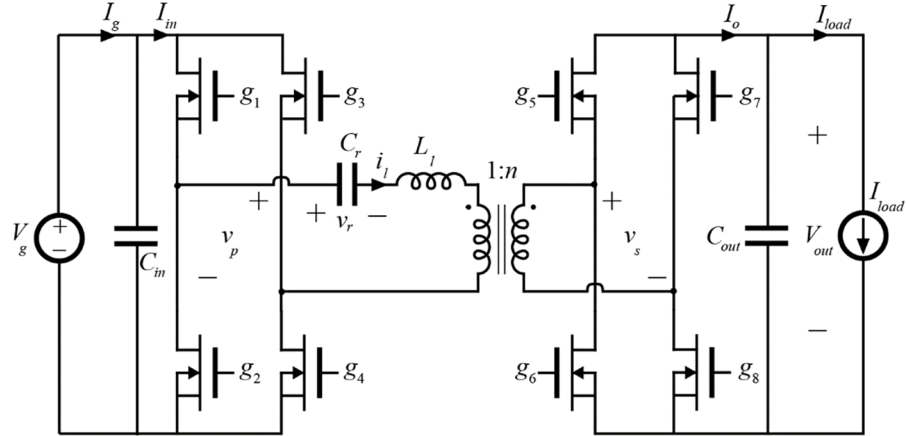
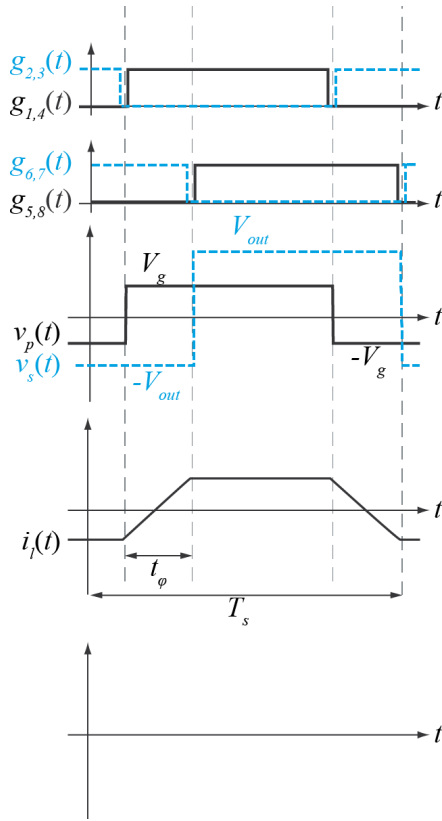

Series Resonant Converter

