

# A Few Things

Will accelerate pace.

Please **pre**view the slides before each class.

Sometimes old slide sets are not updated on the course website.

Test 2 will be take-home

Thu 11/17/2022 (class canceled)

Final Exam: Fri 12/9 in this classroom

# Magnetostatics: Part 1

We present magnetostatics in comparison with electrostatics.

Sources of the fields:

Electric field  $\mathbf{E}$ : Coulomb's law.

Charge  $\rightarrow \mathbf{E}$

Magnetic field  $\mathbf{B}$ : Biot-Savart law.

Current (moving charge)  $\rightarrow \mathbf{B}$

Forces exerted by the fields:

Electric:  $\mathbf{F} = q\mathbf{E}$

Magnetic:  $\mathbf{F} = q\mathbf{v} \times \mathbf{B}$

$$\vec{F} = q \vec{E}$$
$$\vec{F} = q \vec{v} \times \vec{B}$$

Mind the notations, both printed and hand-written

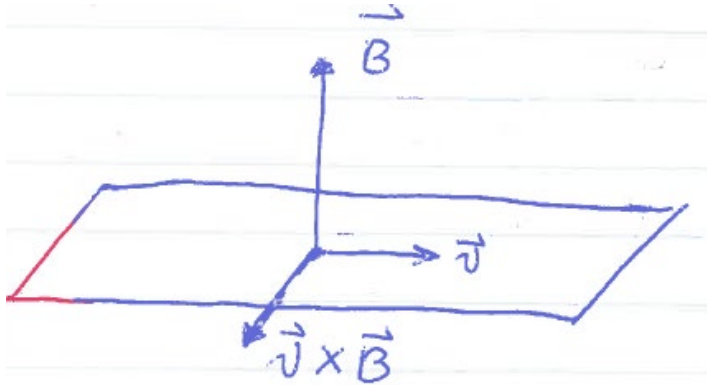

$$\mathbf{F} \perp \mathbf{B}, \mathbf{F} \perp \mathbf{v}$$

Does the magnetic force do any work to the charge?

Positive charge moving at  $\mathbf{v} \perp \mathbf{B}$

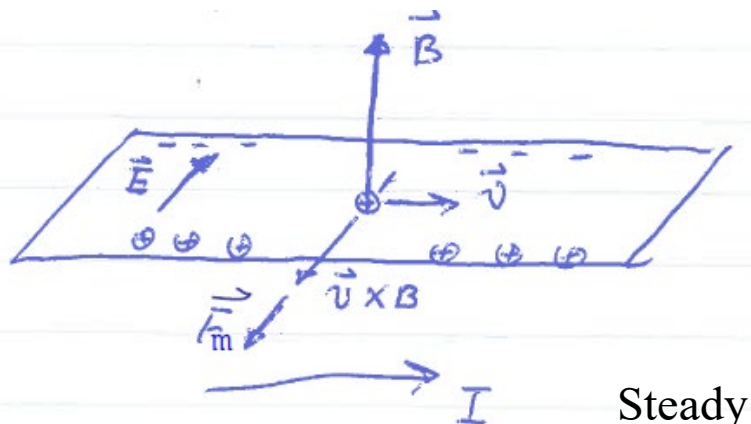

Steady state:  $E = vB$

Negative charge moving at  $\mathbf{v} \perp \mathbf{B}$

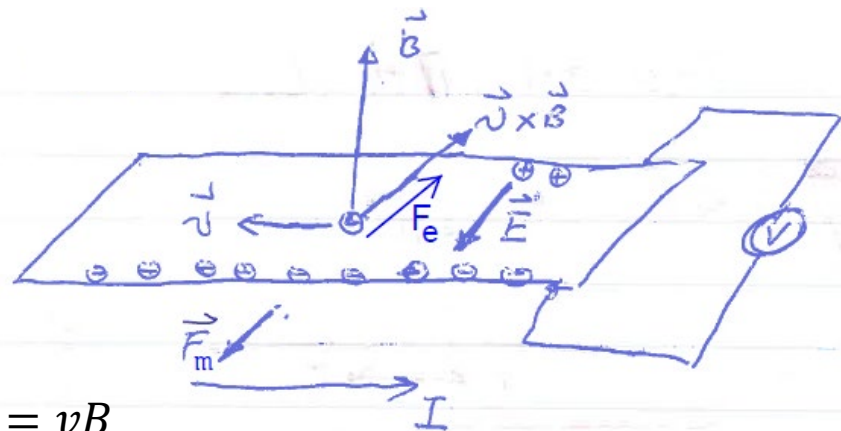

We paused here on Tue 4/19/2022. Please work on Problems 1 & 2 of HW10 to prepare for the next class.

By measuring the polarity of the induced voltage, we can determine the sign of the moving charge.

If the moving charge carriers are in a perfect conductor, then we can have an electric field inside the perfect conductor. Does this contradict what we have learned in electrostatics?

Similar to what happens in a battery, something non-electrostatic is pushing the charges. We will revisit this question when we discuss the **electromotive force**.

The conductor as a whole experiences a total **external magnetic force** (while the electric force is internal).

Notice that the direction of the magnetic force is the same for both positive and negative charge carriers, **given the same current direction**.

## Magnetic force on a current carrying wire

The magnetic force is in the same direction regardless of the charge carrier sign.

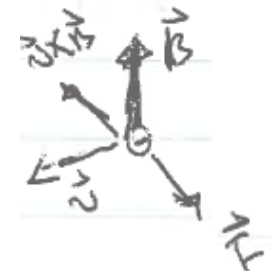
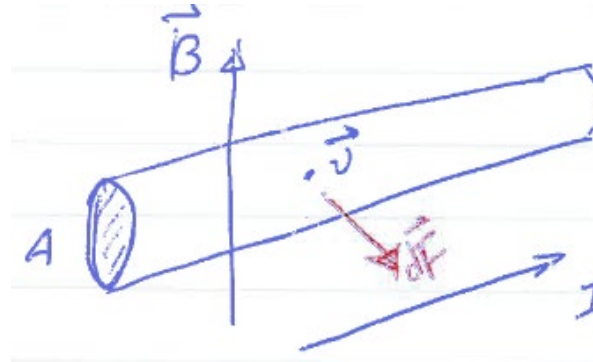

If the charge carrier is negative

$$I = nq v A$$

Carrier density

Charge of each carrier

For a small piece of the wire  $d\mathbf{l}$

$$dQ = nq A dl \quad \text{scalar}$$

$$\begin{aligned} d\vec{F} &= dQ \vec{v} \times \vec{B} = (nq A dl) \vec{v} \times \vec{B} \\ &= nq v A d\vec{l} \times \vec{B} = I d\vec{l} \times \vec{B} \end{aligned}$$

Notice that  $\mathbf{v} \parallel d\mathbf{l}$

$$\boxed{d\mathbf{F} = I d\mathbf{l} \times \mathbf{B}}$$

For a wire from point A to point B,

$$\vec{F} = I \int_A^B d\vec{l} \times \vec{B}$$

For a wire from point A to point B,

$$\vec{F} = I \int_A^B d\vec{\ell} \times \vec{B}$$

For a wire loop,

$$\vec{F} = I \oint d\vec{\ell} \times \vec{B}$$



If **B** is a constant all along the loop,

$$\vec{F} = I \left( \oint d\vec{\ell} \right) \times \vec{B} = 0$$

because

$$\oint d\vec{\ell} = 0$$

Let's look at a rectangular wire loop in a uniform magnetic field **B**.

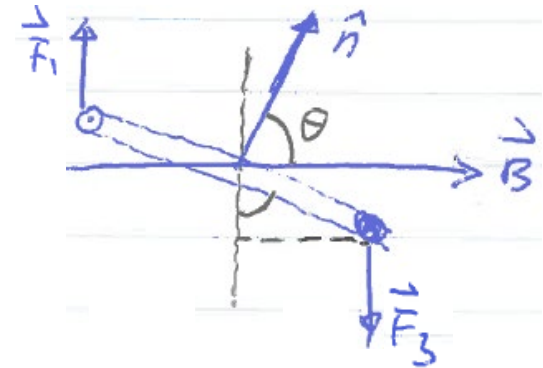
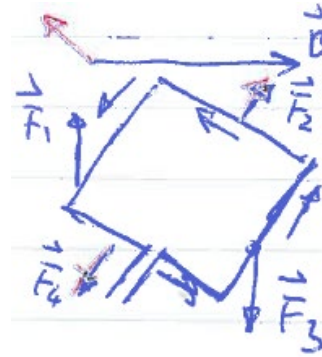
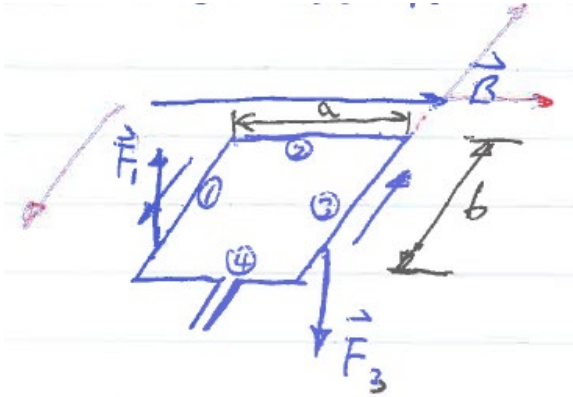

$$\mathbf{F}_1 + \mathbf{F}_3 = 0, \mathbf{F}_2 = \mathbf{F}_4 = 0$$

$$\mathbf{F}_1 + \mathbf{F}_3 = 0, \mathbf{F}_2 + \mathbf{F}_4 = 0$$

At any position, the total force is 0. Will the loop move?

A rectangular wire loop in a uniform magnetic field  $\mathbf{B}$ .

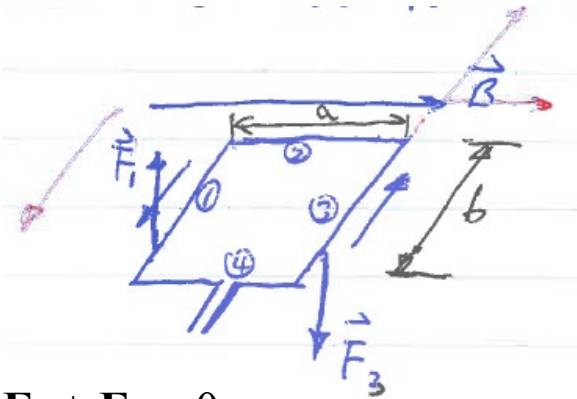

$$\mathbf{F}_1 + \mathbf{F}_3 = 0.$$

$F_2 = F_4 = 0$  since these sides  $\parallel \mathbf{B}$ .

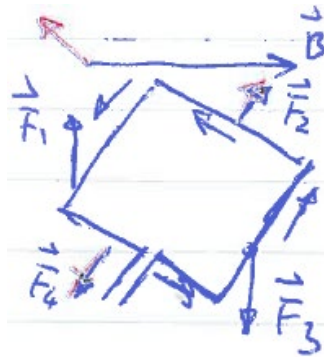

$$\mathbf{F}_1 + \mathbf{F}_3 = 0, \mathbf{F}_2 + \mathbf{F}_4 = 0.$$

Therefore no translation.

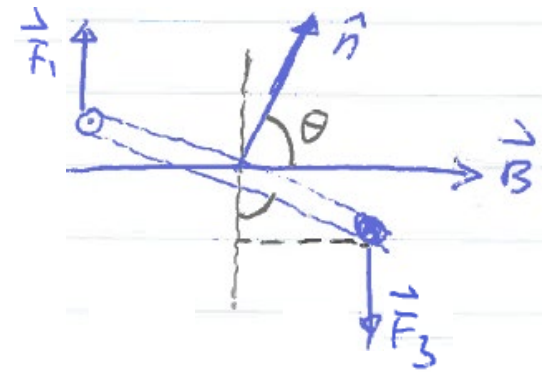

At any position, the total force is 0. Therefore the center of mass does not move.

But there is a torque  $\mathbf{T}$ , driving the loop to rotate.

$$\begin{aligned} T &= F_1 \frac{a}{2} \sin \theta + F_3 \frac{a}{2} \sin \theta \\ &= F a \sin \theta = I b B a \sin \theta = \mathbf{I A B} \sin \theta \end{aligned}$$

Area

Torque  $\mathbf{T}$  is a **vector**. Its direction is defined according to the **right hand rule**.

Angular velocity  $\omega$    
(**vector**)

Similar to Newton's 2<sup>nd</sup> law, the angular **acceleration** (**vector**) is proportional to net torque.

This is the principle behind many motors.

For a planar wire loop in a uniform magnetic field  $\mathbf{B}$ ,

$$T = IAB \sin \theta = IA|\hat{\mathbf{n}} \times \mathbf{B}|.$$

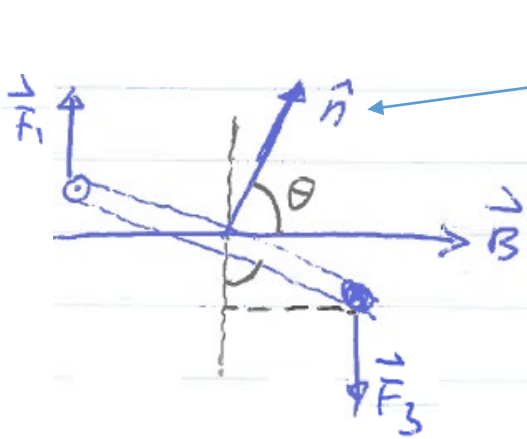

Normal unit vector of the loop

Define the magnetic moment  $\vec{m} = IA \hat{\mathbf{n}}$

so that we can conveniently write

$$\vec{T} = \vec{m} \times \vec{B}$$

Direction of  $\mathbf{T}$  so defined, we have

$$\frac{d\omega}{dt} \propto \mathbf{T}$$

If the loop has  $N$  turns,  $\vec{m} = NIA \hat{\mathbf{n}}$

An  $N$ -turn wire loop is described by a magnetic moment  $\mathbf{m} = NIA\hat{\mathbf{n}}$ .  
A locally uniform (within loop area) magnetic field  $\mathbf{B}$  exerts to the loop a torque

$$\vec{T} = \vec{m} \times \vec{B}, \quad \frac{d\omega}{dt} \propto \mathbf{T}.$$

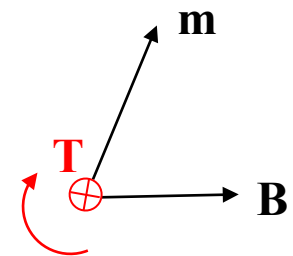

Although derived for a rectangular loop, **this relation is general.**

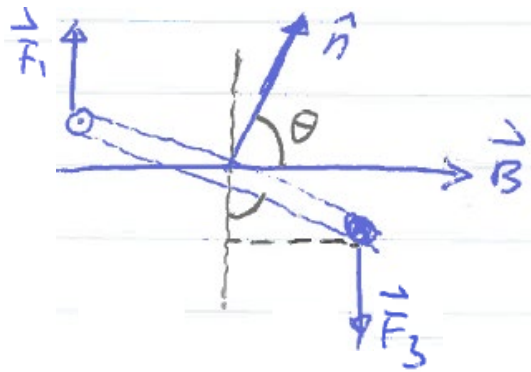

$$\vec{m} = NIA \hat{n}$$

$$\vec{T} = \vec{m} \times \vec{B}$$

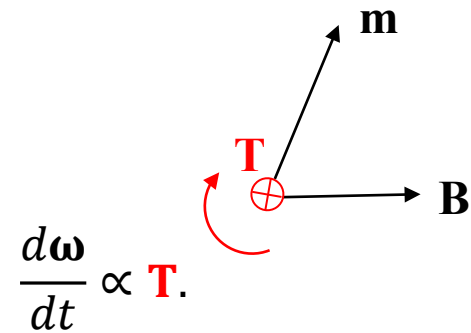

$$\frac{d\omega}{dt} \propto \mathbf{T}.$$

This is the principle of many electric motors.

We know that a magnetic field does not do work.

But in the motor the magnetic field provides the torque that drives the coil to rotate, and the coil can drive a load. Work is done.

What does the work?

**Hint:** The magnetic field can be provided by a permanent magnet, which does not fade because the motor is running. In other words, no energy is taken from or given to the permanent magnet.



# More on motors (for your possible interest)

## DC motor

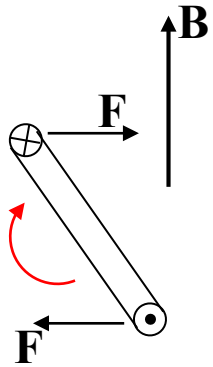

No torque, but coil keeps rotating due to inertia

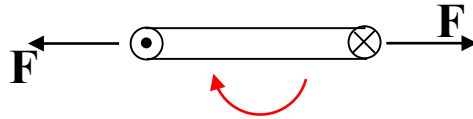

If current flows in same direction

Coil will eventually stop

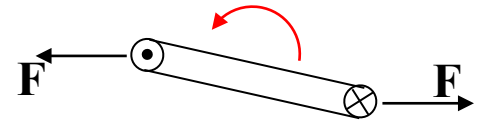

If current reverses direction

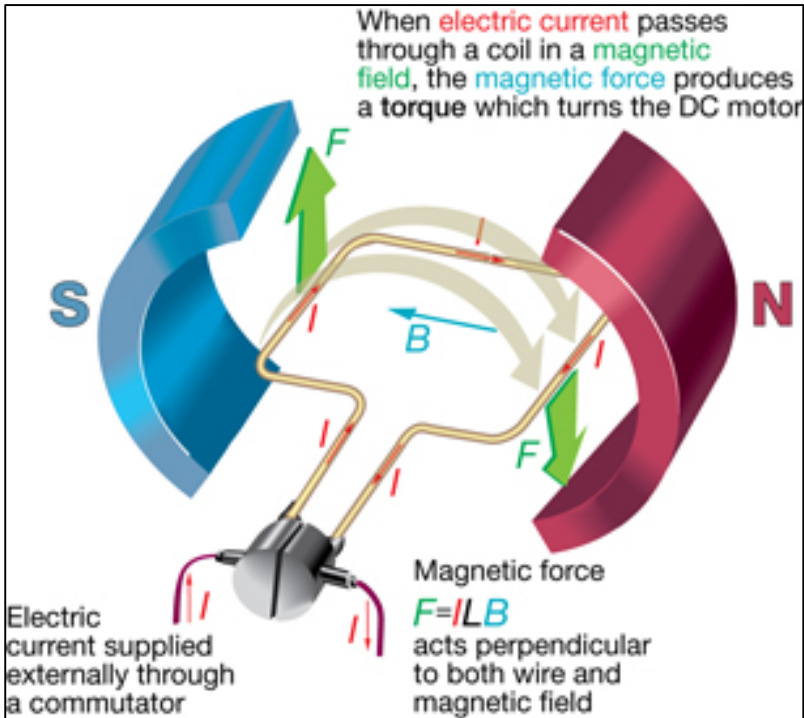
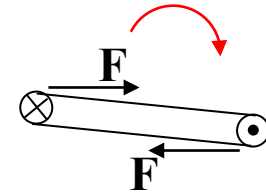

[http://resource.rockyview.ab.ca/rvlc/physics30\\_BU/Unit\\_B/m4/p30\\_m4\\_i03\\_p4.html](http://resource.rockyview.ab.ca/rvlc/physics30_BU/Unit_B/m4/p30_m4_i03_p4.html)

See also:

<https://www.youtube.com/watch?v=Y-v27GPK8M4>

## FYI: AC Motor

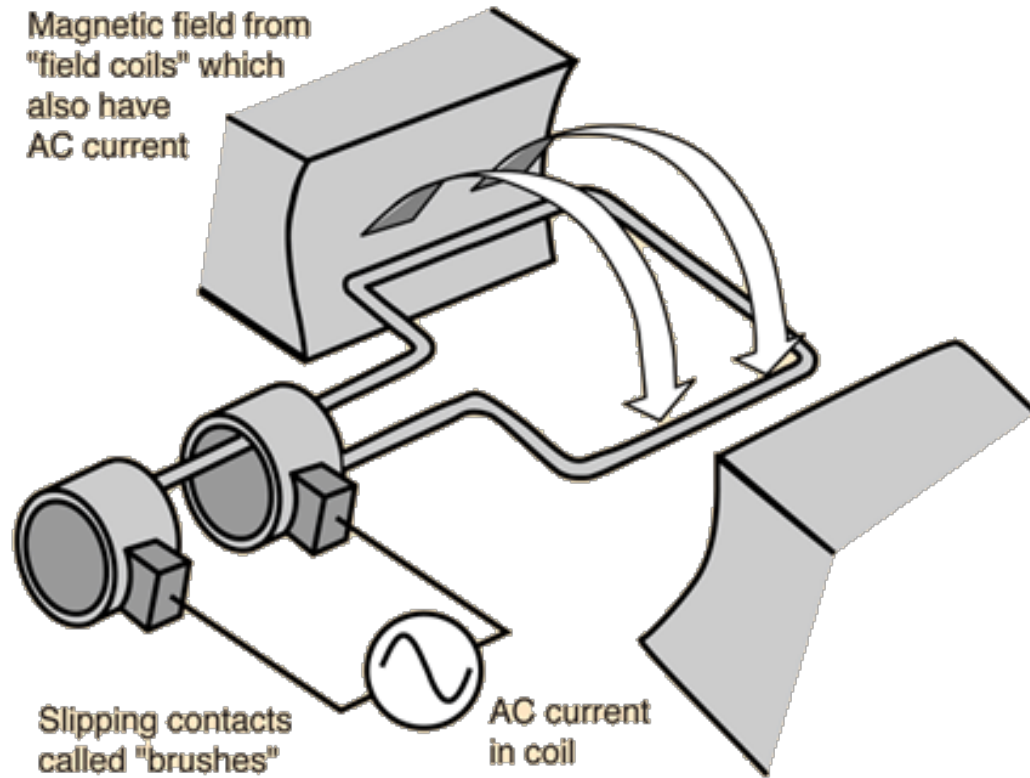

Rotates at the frequency of the sine wave: "synchronous motor".  
Random rotation direction.

<http://hyperphysics.phy-astr.gsu.edu/hbase/magnetic/motorac.html>

The unit of magnetic field **B**

$$\vec{F} = q \vec{v} \times \vec{B}$$

$$[\text{unit of } B] = \frac{\text{newton}}{\text{coulomb} \frac{\text{m}}{\text{s}}} = \frac{\text{N}}{\text{A m}} \equiv \text{tesla}$$

For charge  $q$  in electric field **E**,  $\mathbf{F} = q\mathbf{E}$ . Therefore  $vB$  and  $E$  are the same dimension.

$$[\text{unit of } B] = \frac{\text{V/m}}{\text{m/s}} = \frac{\text{Vs}}{\text{m}^2} \equiv \text{T}$$

We will revisit this topic later, giving you other forms of the unit tesla (T).

We have discussed the force exerted by a magnetic field on **moving** charges.

Next, let's see how the magnetic field is generated.

Review textbook: Sections 5-1.

Finish Problems 1 & 2 of Homework 10.

An electric **current** (i.e. **moving charges**) generates a magnetic field.  
Again, we talk about this in comparison with the electrostatic counterpart.  
But the point charge is not analogous to the **current element** ( $I d\mathbf{l}$ ).

---

### Magnetic field (Biot-Savart law)

$$d\vec{H} = \frac{I}{4\pi} \frac{d\vec{l} \times \hat{R}}{R^2} \Rightarrow d\vec{H} \perp \vec{R}$$

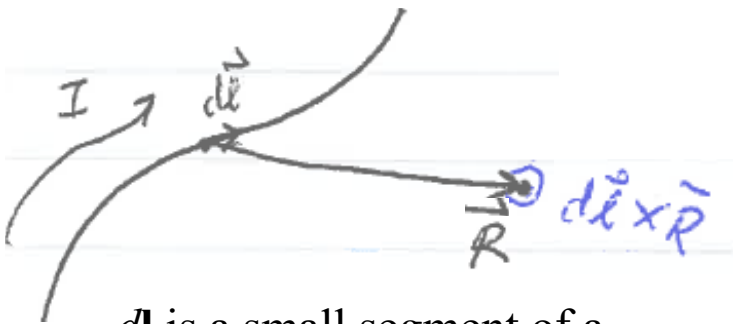

$d\mathbf{l}$  is a small segment of a wire carrying a current  $I$

An electric **current** (i.e. **moving charges**) generates a magnetic field.  
 Again, we talk about this in comparison with the electrostatic counterpart.

Electric field

Consider  $\rho dV$  as the analogue of  $I d\mathbf{l}$ .

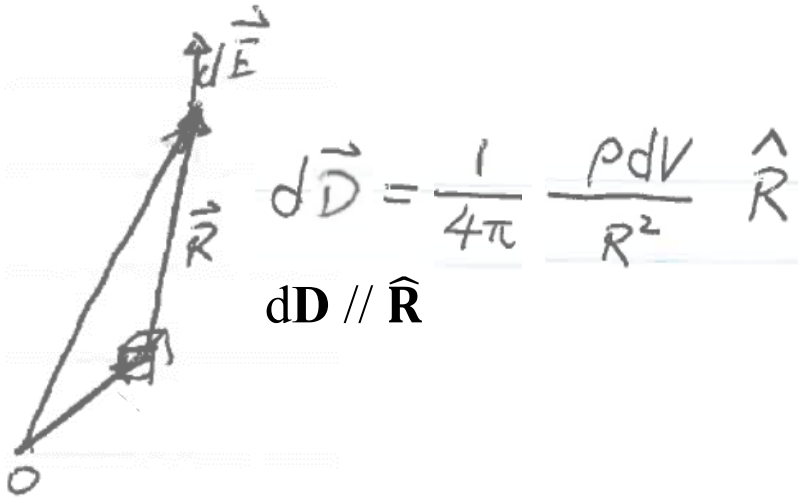

Magnetic field (Biot-Savart law)

$$d\vec{H} = \frac{1}{4\pi} \frac{I d\vec{l} \times \hat{R}}{R^2} \Rightarrow d\vec{H} \perp \vec{R}$$

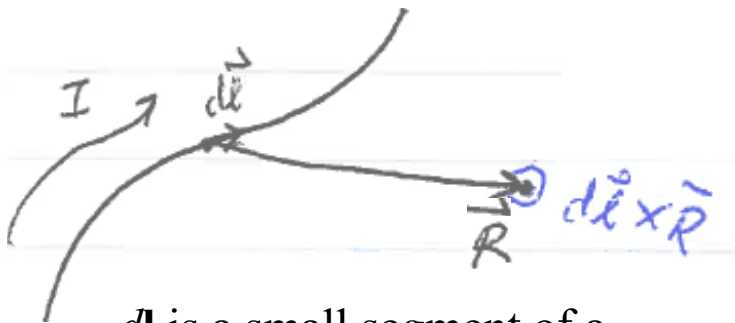

$d\mathbf{l}$  is a small segment of a wire carrying a current  $I$

## Slight notation change

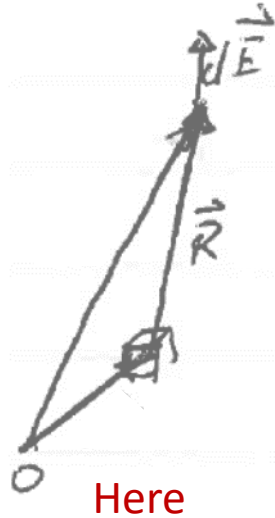
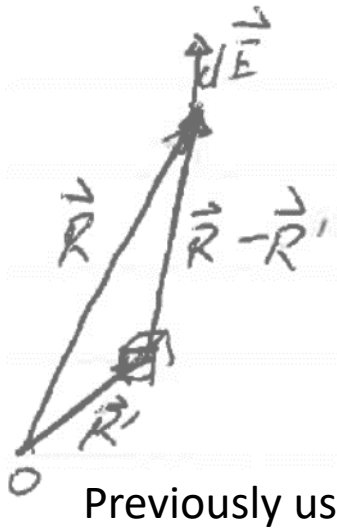

Here,  $\mathbf{R}$  is the vector from a volume element  $dV$  to the point where we want to find  $d\mathbf{E}$ .

$$d\vec{E} = \frac{1}{4\pi\epsilon} \frac{\rho dV}{R^2} \hat{R}$$

$\rho$  includes only the “external” charge, not the polarization charge, which is taken care of by the material (medium) parameter  $\epsilon$ .

Regardless of the medium, we can write this equation in terms of  $\mathbf{D}$ .

$$\mathbf{D} \equiv \epsilon_0 \epsilon_r \mathbf{E} \equiv \epsilon \mathbf{E}$$

$$d\vec{D} = \frac{1}{4\pi} \frac{\rho dV}{R^2} \hat{R}$$

$\mathbf{D}$  is what the external charge distribution  $\rho$  generates.

$\mathbf{E}$  is what a probe charge  $q$  feels:  $\mathbf{F} = q\mathbf{E}$ .

(Contribution to  $\mathbf{E}$  by polarization charge is accounted for by  $\epsilon_r$ .)

An electric **current** (i.e. **moving charges**) generates a magnetic field. Again, we talk about this in comparison with the electrostatic counterpart.

Electric field

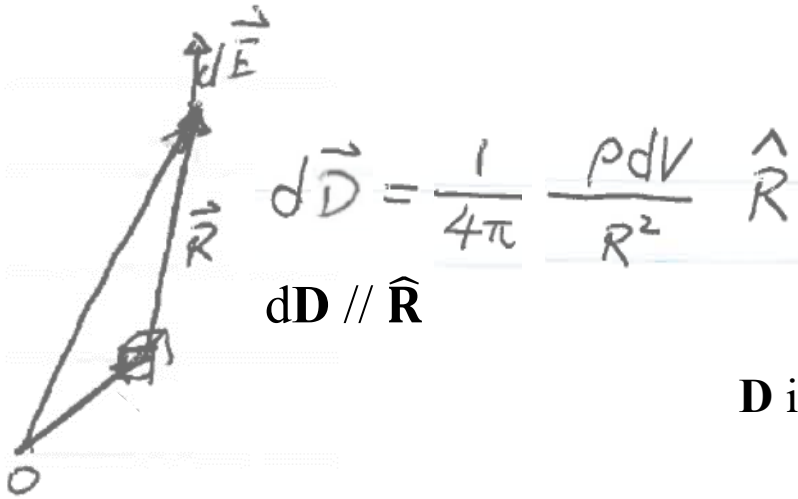

$$d\vec{D} = \frac{1}{4\pi} \frac{\rho dV}{R^2} \hat{R}$$

$d\mathbf{D} \parallel \hat{\mathbf{R}}$

$\rho$  includes only the “**external**” charge, **not** the polarization charge, which is taken care of by the material (medium) parameter  $\epsilon$ .

Both fields are proportional to  $1/R^2$ .

$\mathbf{D}$  is what the **external** charge distribution  $\rho$  generates.

Magnetic field (Biot-Savart law)

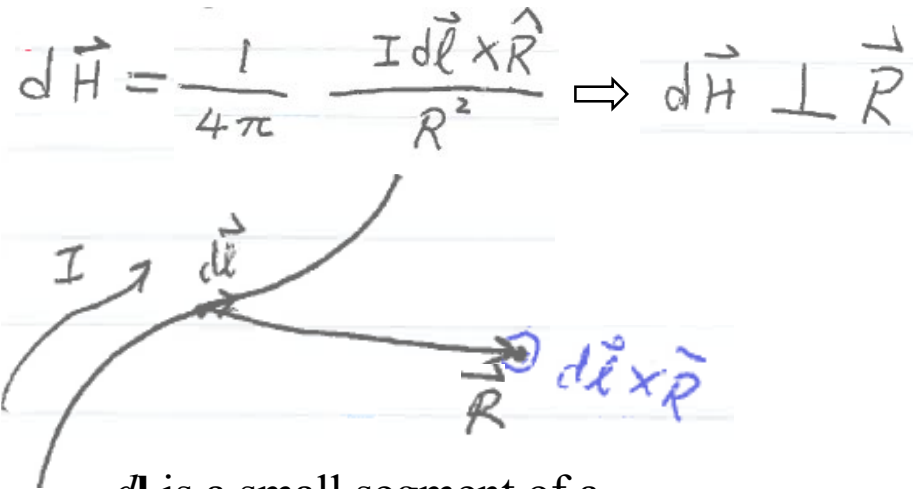

$$d\vec{H} = \frac{1}{4\pi} \frac{I d\vec{l} \times \hat{R}}{R^2} \Rightarrow d\vec{H} \perp \vec{R}$$

$I$  includes only the “**external**” current, not the **magnetization current**, which is accounted for by the material (medium) parameter  $\mu$  (**to be discussed later**).

$\mathbf{H}$  is what the current  $I$  generates.

$d\mathbf{l}$  is a small segment of a wire carrying a current  $I$

An electric **current** (i.e. **moving charges**) generates a magnetic field. Again, we talk about this in comparison with the electrostatic counterpart.

Electric field

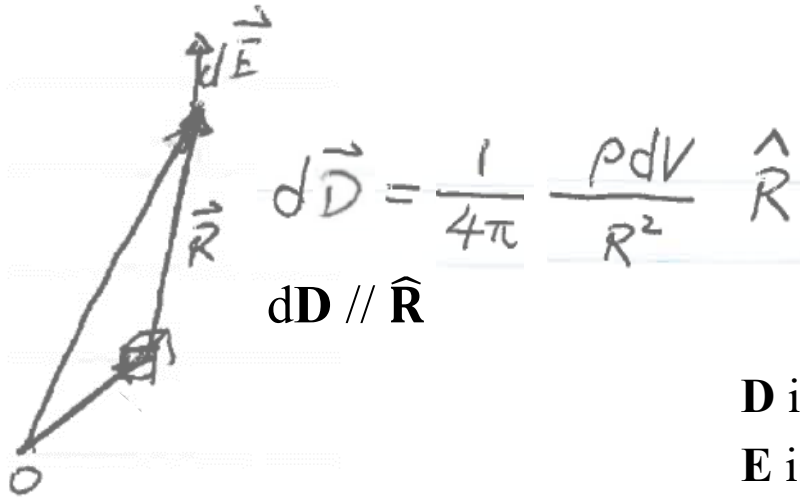

$\rho$  includes only the “**external**” charge, **not** the polarization charge, which is taken care of by the material (medium) parameter  $\epsilon$ .

Both fields are proportional to  $1/R^2$ .

$$\mathbf{D} \equiv \epsilon_0 \epsilon_r \mathbf{E} \equiv \epsilon \mathbf{E}$$

$\mathbf{D}$  is what the **external** charge distribution  $\rho$  generates.

$\mathbf{E}$  is what a probe charge  $q$  feels:  $\mathbf{F} = q\mathbf{E}$ .

Magnetic field (Biot-Savart law)

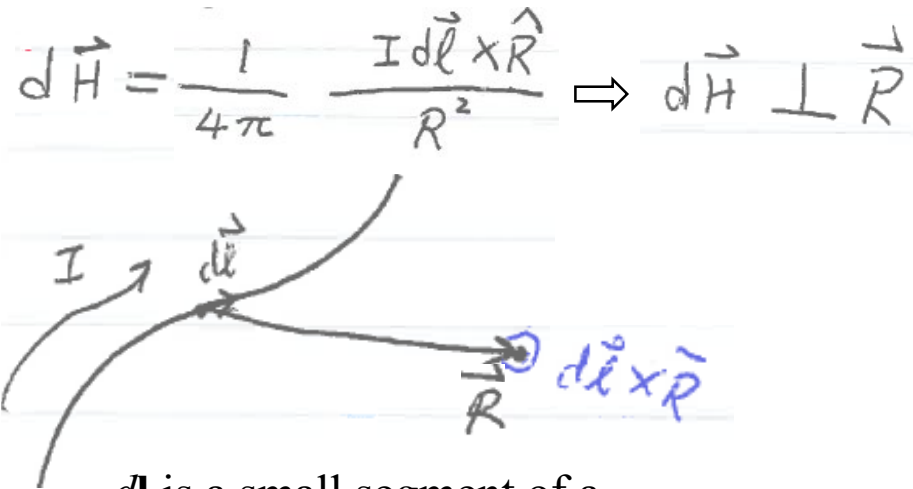

$I$  includes only the “**external**” current, not the **magnetization current**, which is accounted for by the material (medium) parameter  $\mu$  (**to be discussed later**).

$$\mathbf{B} = \mu_0 \mu_r \mathbf{H} = \mu \mathbf{H}$$

$\mathbf{H}$  is what the current  $I$  generates.

$\mathbf{B}$  is what a probe charge  $q$  feels:  $\mathbf{F} = q\mathbf{v} \times \mathbf{B}$ .

$d\mathbf{l}$  is a small segment of a wire carrying a current  $I$



## Example 1: Magnetic field of a current-carrying straight wire of finite length

Read on your own. **Example 5-2** of textbook: pp. 237 in 8/E (pp. 245 in 7/E).

Just sum up piece by piece (taking the integral). This example is for you to appreciate the shape of the magnetic field in relation to the current.

But, you need to have a closed circuit. The solution is a good approximation only far away from other parts of the circuit. See **Problem 3** of Homework 10.

Take this good approximation to the limit of an **infinitely long straight wire**, we have

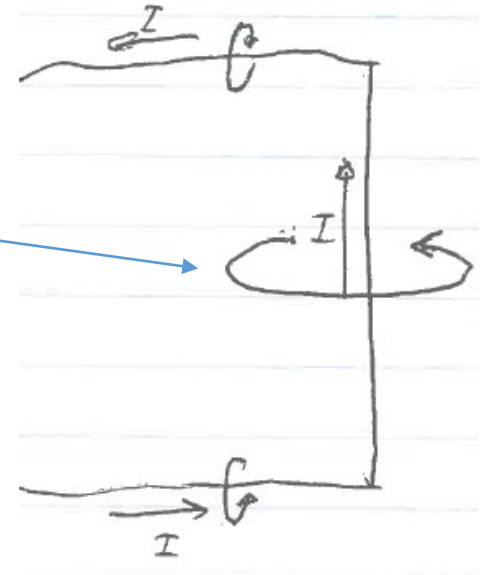

$$\vec{H} = \frac{I}{2\pi r} \hat{\phi} \leftarrow \text{Unit vector in the } \phi \text{ direction in the cylindrical coordinate}$$

We will discuss an easier way to get to this equation later.

From this equation, you see the unit of  $\mathbf{H}$  is **A/m**.

Using the result for the wire of a finite length, do Homework 10 **Problem 3**.

Using the result for the infinitely long wire, do Homework 10 **Problem 4**.

(Problem not well stated. Change “power cable” to “DC current-carrying wire”, as we usually understand a “power cable” as two wires carrying opposite AC currents.)

## Example 2: Magnetic field of a current-carrying circular wire loop

Find the magnetic field at any location  $z$  on the axis of a current-carrying circular ring.

The gap is made small, therefore can be ignored.

So, treat it the same as **Example 5-3** of textbook. But this is more realistic.

The feed wires carry opposite currents, therefore contribute no magnetic field.

Just sum up piece by piece (taking the integral). This example is, again, for you to appreciate **the shape of the magnetic field in relation to the current**.

$$d\vec{H} = \frac{1}{4\pi} \frac{I d\vec{l} \times \hat{R}}{R^2}$$

$$d\vec{l} \perp \hat{R} \Rightarrow |d\vec{l} \times \hat{R}| = dl$$

Horizontal components due to diametrical elements cancel. Therefore consider only vertical component of  $d\vec{H}$ :

$$dH_z = \frac{I dl}{4\pi R^2} \cos \theta$$

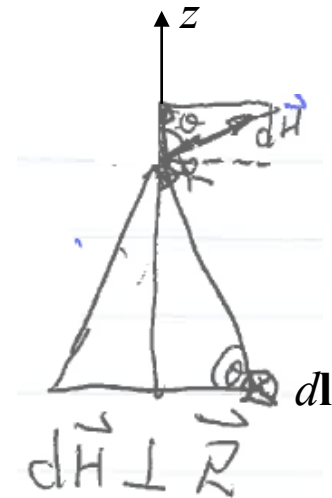
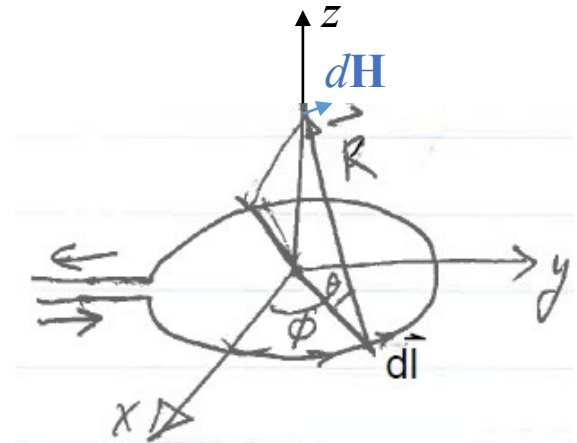

$$dH_z = \frac{I dl}{4\pi R^2} \cos \theta$$

Perimeter (circumference)

$$H = H_z = \oint dH_z = \oint \frac{I dl}{4\pi R^2} \cos \theta = \frac{I \cos \theta}{4\pi R^2} \oint dl$$

$$= \frac{I \cos \theta}{4\pi R^2} 2\pi a = \frac{I}{2R^2} a \cos \theta$$

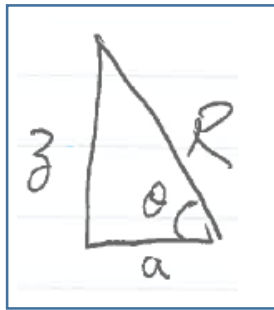
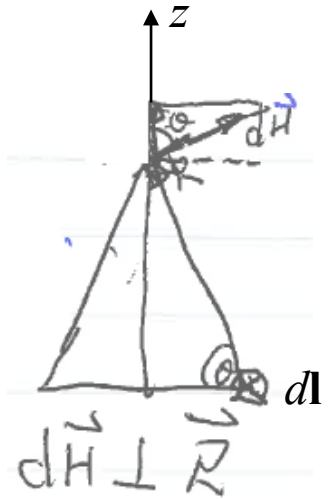

$$= \frac{I a}{2(a^2 + z^2)} \cdot \frac{a}{\sqrt{a^2 + z^2}}$$

$$= \frac{I a^2}{2(a^2 + z^2)^{3/2}}$$

Work out the math details offline on your own and then check with the book.

$$H(z=0) = \frac{I a^2}{2 a^3} = \frac{I}{2a}$$

Near field

$$H(z \gg a) = \frac{I a^2}{2 |z|^3}$$

Far field

$$H(z=0) = \frac{Ia^2}{2a^3} = \frac{I}{2a}$$

Near field

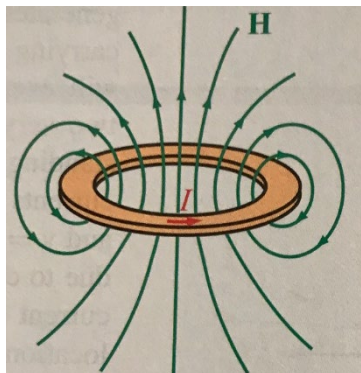

$$H(z \gg a) = \frac{Ia^2}{2|z|^3}$$

Far field

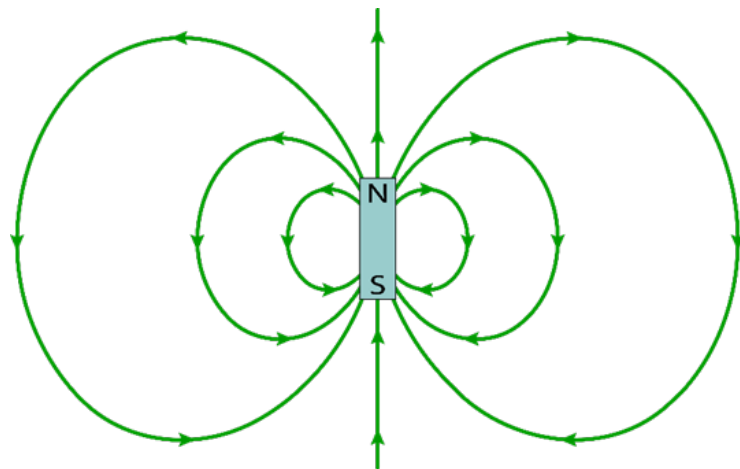

[http://www.thesciencemill.com/Research/edm/edm\\_paper.php](http://www.thesciencemill.com/Research/edm/edm_paper.php)

The big pictures:  
not limited to the  
z axis

Again, far from the loop, the shape of the loop does not matter. The far field is the same as a small magnet.

For the far field, recall that we defined  $m = IA = I\pi a^2$

$$\therefore H(z \gg a) = \frac{m}{2\pi|z|^3} \Rightarrow$$

$$\vec{H}(z \gg a) = \frac{\vec{m}}{2\pi|z|^3}$$



$\mathbf{H} \parallel \mathbf{m}$

Direction of  $\mathbf{m}$  follows right hand rule.

Any current carrying loop has a **magnetic moment  $\mathbf{m}$** , and the loop is called a **magnetic dipole**. It's equivalent to a small magnet. (We will talk explain why when we discuss magnetic materials.)

There is no need for a physical wire. For example, an electron orbiting a nucleus forms a magnetic dipole. (More on this when we discuss magnetic properties of materials.)

We call such a loop a magnetic dipole because its magnetic field has the same shape as the electric field of the electric dipole, when we consider only the **far field**.

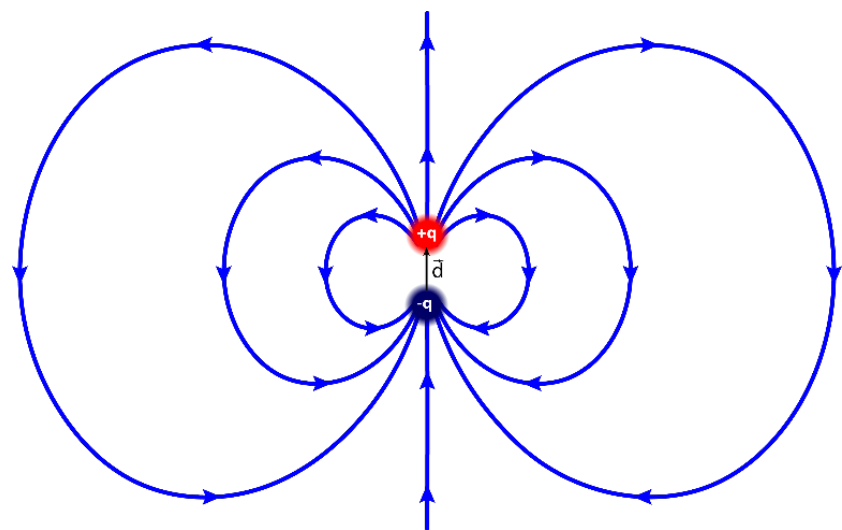
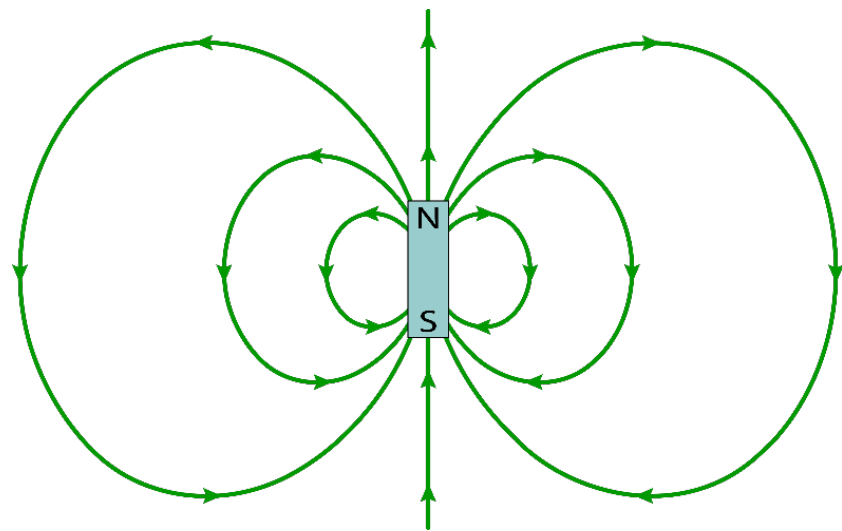

If you zoom in and look at the near field, you will see a big difference.

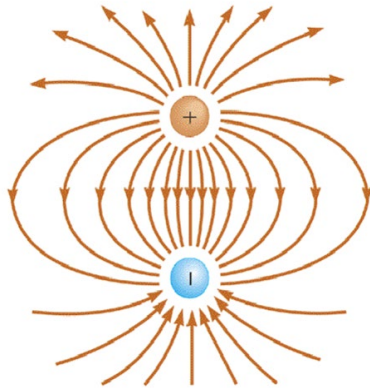

<http://physics.stackexchange.com/questions/318150/how-do-electric-field-lines-form-only-open-loops>

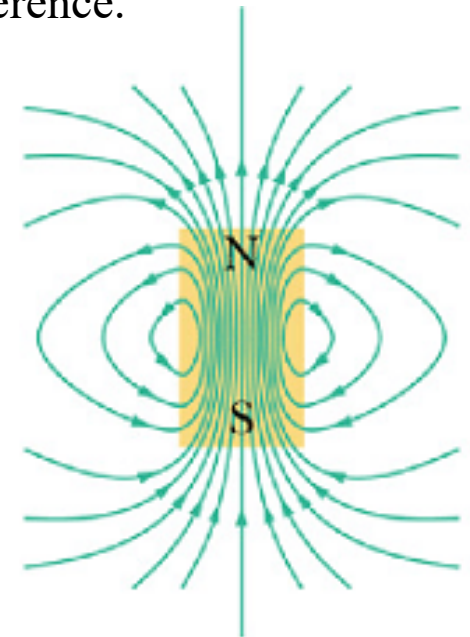
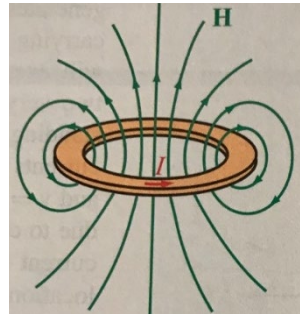

<http://www.rakeshkapoor.us/ClassNotes/classnotes.php?notes=MagneticField&index=2>

Electric dipole: **E** lines come out of + charge and end at – charge. In math language,

$$\nabla \cdot \vec{D} = \rho$$

$$\oint \vec{D} \cdot d\vec{S} = \int \rho dV$$

Magnetic dipole: **B** lines form loops. In math language,

$$\nabla \cdot \vec{B} = 0$$

$$\oint \vec{B} \cdot d\vec{S} = 0$$

There is no such thing as “magnetic charge”.

Since the **electrostatic** field  $\mathbf{E}$  must go from the  $+$  charge into the  $-$  charge, its field lines cannot form loops.

Mathematically,

$$\oint \vec{E} \cdot d\vec{l} = 0$$

$$\nabla \times \vec{E} = 0$$

Will explain this notation

Such a field is said to be **conservative**.

$$\nabla \cdot \vec{D} = \epsilon \nabla \cdot \vec{E} = \rho$$

$$\oint \vec{D} \cdot d\vec{S} = \epsilon \oint \vec{E} \cdot d\vec{S} = \int \rho dV$$

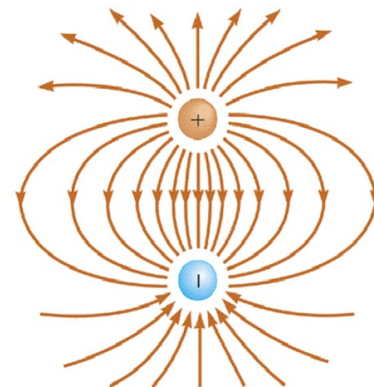

In contrast, the magnetic field must form loops.

Such a field is said to be **solenoidal**.

The loop integral of the magnetic field is therefore finite. What is it?

$$\nabla \cdot \vec{B} = 0 \quad \oint \vec{B} \cdot d\vec{S} = 0$$

$$\oint \vec{H} \cdot d\vec{l} = \int \vec{J} \cdot d\vec{S} = I$$

Ampère's law

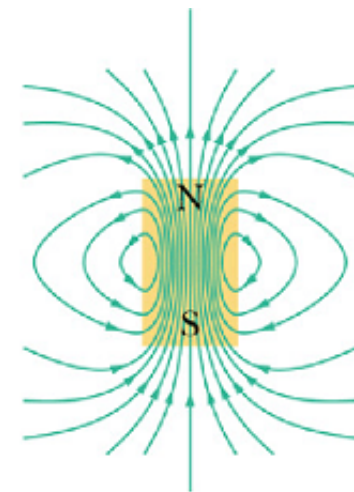
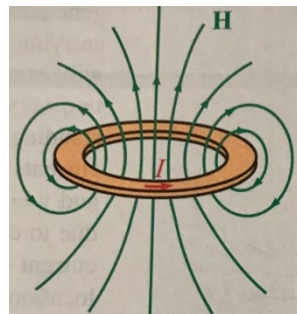

$$\oint \vec{H} \cdot d\vec{\ell} = \int \vec{J} \cdot d\vec{S} = I$$

Ampère's law



Ampère's law is obeyed by all loops, regardless of size.

We shrink a loop to infinitesimally small, and define the “curl”

Shrink this loop (and the area it encloses) to infinitesimally small

$$\text{curl } \vec{H} = \lim_{\Delta S \rightarrow 0} \frac{\vec{n} \oint \vec{H} \cdot d\vec{\ell}}{\Delta S}$$

Unit normal vector



Here, we state the way to calculate the curl in the Cartesian coordinate without proof:

$$\vec{H} = H_x \hat{x} + H_y \hat{y} + H_z \hat{z}$$

$$\nabla \equiv \hat{x} \frac{\partial}{\partial x} + \hat{y} \frac{\partial}{\partial y} + \hat{z} \frac{\partial}{\partial z}$$

$$\nabla \times \vec{H} = \begin{vmatrix} \hat{x} & \hat{y} & \hat{z} \\ \frac{\partial}{\partial x} & \frac{\partial}{\partial y} & \frac{\partial}{\partial z} \\ H_x & H_y & H_z \end{vmatrix} = \hat{x} \left( \frac{\partial H_z}{\partial y} - \frac{\partial H_y}{\partial z} \right) + \hat{y} \left( -\frac{\partial H_z}{\partial x} + \frac{\partial H_x}{\partial z} \right) + \hat{z} \left( \frac{\partial H_y}{\partial x} - \frac{\partial H_x}{\partial y} \right)$$

determinant



## Stoke's theorem (the math)

Consider the loop integral of  $\mathbf{H}$  around the contour  $C$ .

Imagine a dense grid.

For each small loop, by definition:

$$\nabla \times \vec{H} = \text{curl } \vec{H} = \lim_{\Delta S \rightarrow 0} \frac{\vec{n} \oint \vec{H} \cdot d\vec{l}}{\Delta S}$$

Therefore,

$$\oint_C \vec{H} \cdot d\vec{l} = \sum_{\text{small loop}} [\oint \vec{H} \cdot d\vec{l}] = \sum (\nabla \times \vec{H}) \cdot \Delta \vec{S} = \int (\nabla \times \vec{H}) \cdot d\vec{S}$$

This is just math.

Now the physics kicks in:  $\oint \vec{H} \cdot d\vec{l} = \int \vec{J} \cdot d\vec{S} = I$  Integral form (big picture) of Ampère's law

Therefore,  $\nabla \times \vec{H} = \vec{J}$  Differential form (small picture) of Ampère's law

Similarly,  $\oint \vec{E} \cdot d\vec{l} = 0 \iff \nabla \times \vec{E} = 0$



Contour  $C$

### Example 3: Magnetic field of a current-carrying infinitely-long straight wire

Wire carries current  $I$ . Current density uniformly distributed.

$$J = \frac{I}{\pi a^2}$$

For  $r < a$ ,

$$\oint \vec{H} \cdot d\vec{\ell} = H(2\pi r) = \frac{I}{\pi a^2} \cdot \pi r^2 = I \left(\frac{r}{a}\right)^2$$

$$\therefore H = \frac{1}{2\pi r} I \left(\frac{r}{a}\right)^2 = \frac{Ir}{2\pi a^2}$$

For  $r > a$ ,

$$\oint \vec{H} \cdot d\vec{\ell} = 2\pi r H = I$$

$$\therefore H = \frac{I}{2\pi r}$$

Same result as got from Biot-Savart law in Example 1.

$J$  can be non-uniform. For non-uniform  $J$ , do Homework 10 **Problem 6**.

Also finish Homework 10 **Problem 7** (**Problem 3.58** in 8/E of textbook).

For other geometries, read the following in text book:

**Example 5-5 – Toroidal coil**

**Example 5-6 – Infinitely large current sheet**

**Section 5-7.1 – Solenoid** (we put off discussion on inductance)

Go through the mathematical details, but more important, get a visual sense of  $\mathbf{B}$  fields of currents in these geometries. Look at the figures and think.

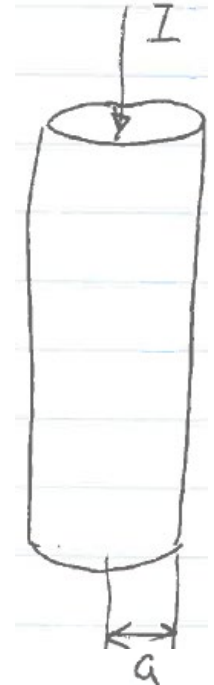

We went through this slide set up to the last slide on Thu 11/10/2022 and will resume from here next time.

Further thinking about **Example 5-6** –  
Infinitely large current sheet

Consider a pair of such sheets with opposite surface current densities:

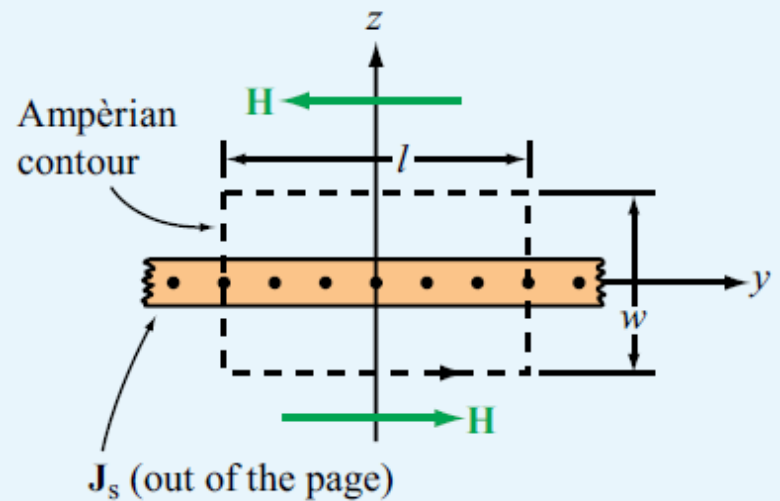
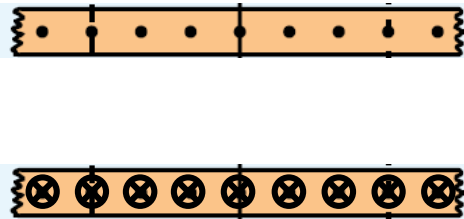

**Figure 5-19** A thin current sheet in the  $x$ - $y$  plane carrying a surface current density  $J_s = \hat{x}J_s$  (Example 5-6).

Compare this with the parallel-plate capacitor.

## Further thinking about Section 5-7.1 – Solenoid

→ The big pictures:  $\mathbf{B}$  field distribution of solenoids of finite lengths

Then, calculate  $\mathbf{B}(z)$  along the axis using the result of **example 2** of this slide set (field along axis of a single wire loop).

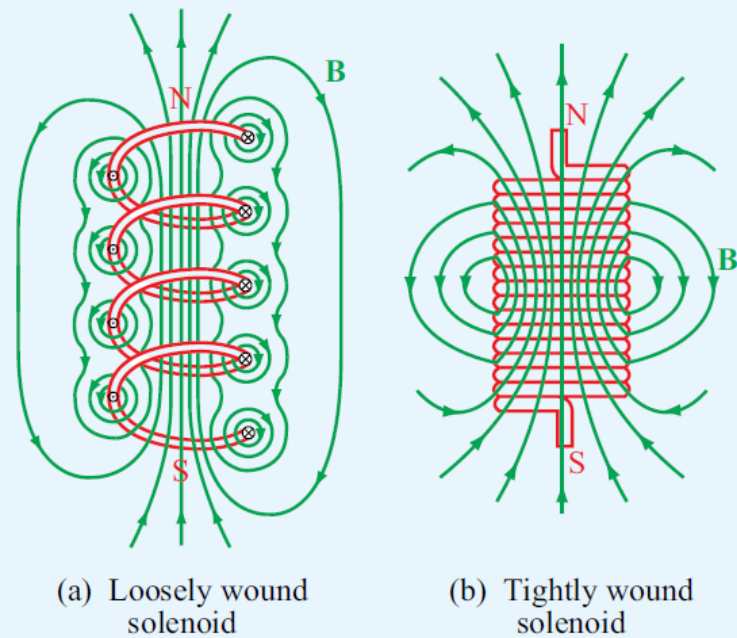

(a) Loosely wound solenoid

(b) Tightly wound solenoid

**Figure 5-25** Magnetic field lines of (a) a loosely wound solenoid and (b) a tightly wound solenoid.

Then, find the limit as solenoid length  $\rightarrow \infty$ .

It is stated that the field inside a long solenoid is uniform.

Try an **alternative way**:

Start from the **ideal model** of infinitely long, tightly wound solenoid. **Mathematically prove (using symmetry argument and logic)** that the  $\mathbf{B}$  field inside is indeed uniform and that  $B = \mu nI$ . Consider the ideal model solenoid so tightly wound that you can treat it in a similar manner as in the previous slide.

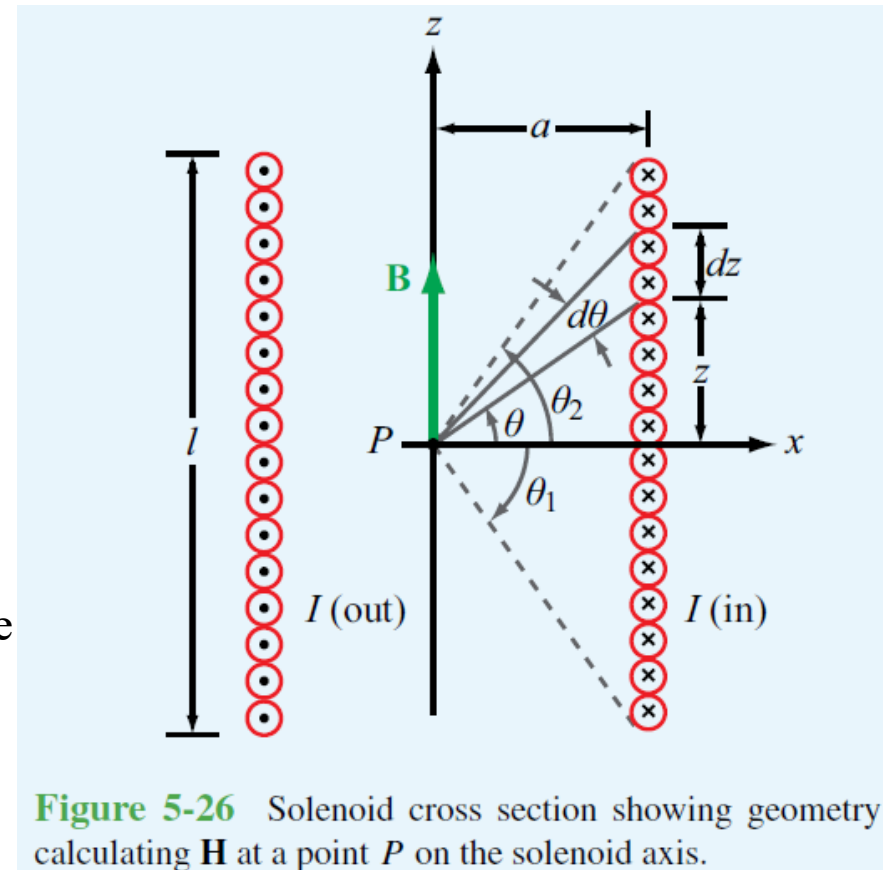

**Figure 5-26** Solenoid cross section showing geometry calculating  $\mathbf{H}$  at a point  $P$  on the solenoid axis.

Now, we consider the interaction between two wires, in comparison with two charged bodies in electrostatics.

What is the force between the two plates of an infinitely large parallel-plate capacitor?

$$E = \frac{\rho_A}{\epsilon}$$

$$\therefore \frac{F}{A} = \frac{\rho_A A}{A} \frac{\rho_A}{\epsilon} = \frac{\rho_A^2}{\epsilon}$$

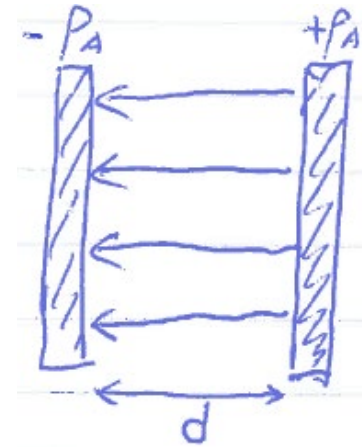

Is this right?

## An old slide from a previous lecture

What we did wrong was double counting, a sort of “creative accounting”.

$$E = \frac{P_s}{\epsilon} = \frac{Q}{\epsilon A} \text{ is the total field due to both plates.}$$

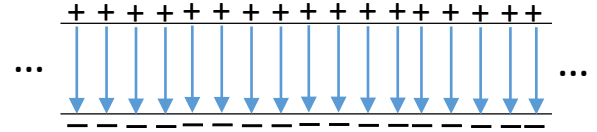

The force is exerted on one plate by the field due to the other.  
Therefore,

$$E = \frac{P_s}{2\epsilon} = \frac{Q}{2\epsilon A}$$

$$W = Fd = QEd = Q \cdot \frac{Q}{2\epsilon A} d = \frac{1}{2} Q^2 \frac{d}{\epsilon A}$$
$$C = \frac{\epsilon A}{d}$$

$$\Rightarrow W = \frac{1}{2} \frac{Q^2}{C}$$
$$Q = CV$$
$$\Rightarrow W = \frac{1}{2} CV^2$$

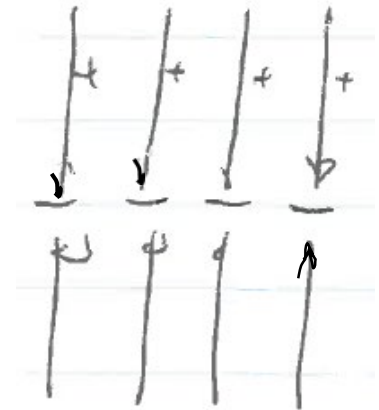

The positive charge sheet  
in the field of the  
negative charge sheet

This another way to appreciate the factor  $\frac{1}{2}$ .

## Example 4: Interaction between two current-carrying infinitely-long straight wires

Similarly, we consider one wire placed in the field of the other.

The distance between the wires is  $d$ .

The field of wire 1 at the location of wire 2 is:

$$H = \frac{I_1}{2\pi d} \quad B = \frac{\mu_0 I_1}{2\pi d}$$

Therefore the force on wire 2 is

$$\frac{F}{l} = \frac{l}{l} \cdot I_2 l \cdot \frac{\mu_0 I_1}{2\pi d} = \frac{\mu_0 I_1 I_2}{2\pi d}$$

Pay attention to the direction:

Two wires carrying currents in the same direction **attract** each other.

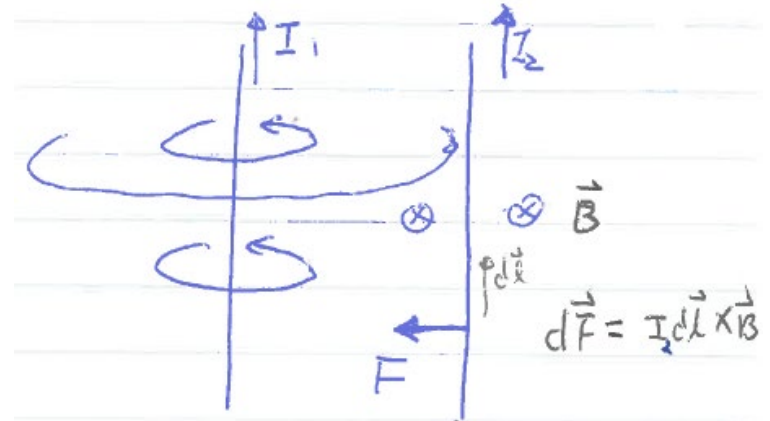

Do Homework 10 **Problem 5**.

Review textbook: Chapter 5 Overview, Sections 5-1 through 5-3  
Finish Homework 10.