

The Smith Chart

One-to-one mapping between Γ and z_L

$$\Gamma = \frac{z_L - 1}{z_L + 1}$$

$$z_L = \frac{1 + \Gamma}{1 - \Gamma}$$

More generally, anywhere along the transmission line

$$z(d) \equiv \frac{Z(d)}{Z_0} = \frac{1 + \Gamma_d}{1 - \Gamma_d}$$

The math looks simple. But Γ and z_L are generally both complex.

Actual calculation is tedious. A graphical tool desired (esp. before the computer age).

Same math for load and point d . So same tool.

Let's now develop the tool.

$$\Gamma = |\Gamma| e^{j\theta_r} \equiv |\Gamma| \angle \theta_r = \Gamma_r + j\Gamma_i$$

$$z_L = r_L + jx_L \quad (\text{normalized})$$

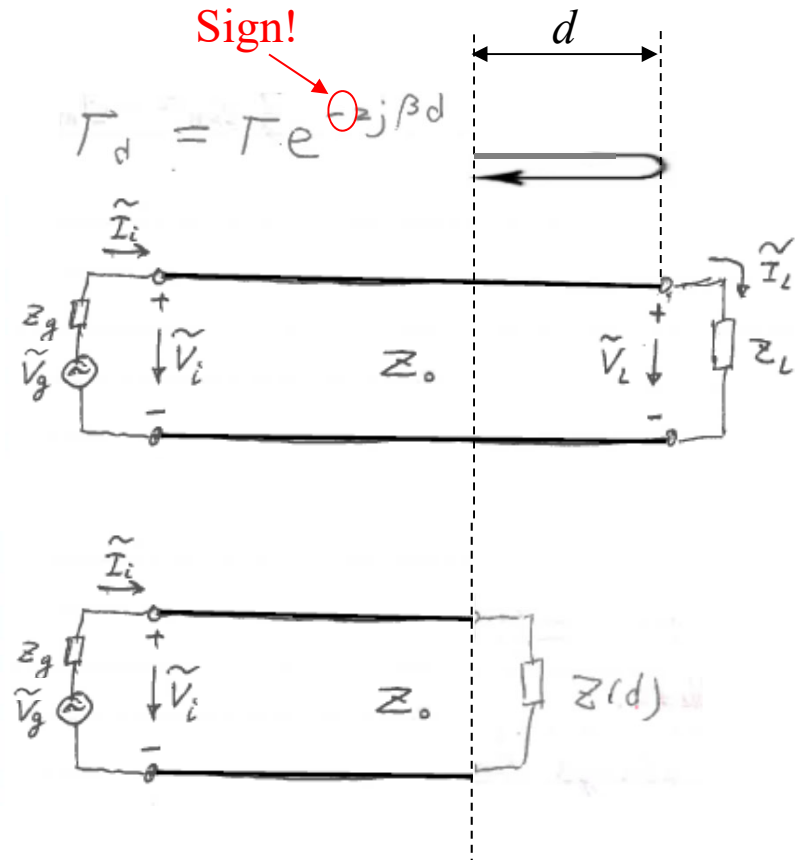

Insert $\begin{cases} \Gamma = \Gamma_r + j\Gamma_i \\ z_L = r_L + jx_L \end{cases}$ into $z_L = \frac{1 + \Gamma}{1 - \Gamma}$, then use

$$\text{Re(left side)} = \text{Re(right side)} \quad \Rightarrow \quad r_L = \frac{1 - \Gamma_r^2 - \Gamma_i^2}{(1 - \Gamma_r)^2 + \Gamma_i^2}$$

$$\Rightarrow \left(\Gamma_r - \frac{r_L}{1 + r_L} \right)^2 + \Gamma_i^2 = \left(\frac{1}{1 + r_L} \right)^2$$

This is the equation for the **locus** of all $\Gamma = \Gamma_r + j\Gamma_i$ that correspond to a given r_L .

 What does this word mean?

Insert $\begin{cases} \Gamma = \Gamma_r + j\Gamma_i \\ z_L = r_L + jx_L \end{cases}$ into $z_L = \frac{1 + \Gamma}{1 - \Gamma}$, then use

$$\text{Re(left side)} = \text{Re(right side)} \quad \Rightarrow \quad r_L = \frac{1 - \Gamma_r^2 - \Gamma_i^2}{(1 - \Gamma_r)^2 + \Gamma_i^2}$$

$$\Rightarrow \left(\Gamma_r - \frac{r_L}{1 + r_L} \right)^2 + \Gamma_i^2 = \left(\frac{1}{1 + r_L} \right)^2$$

This is the equation for the **locus** of all $\Gamma = \Gamma_r + j\Gamma_i$ that correspond to a given r_L .

Example: A circle is the locus of all points that are at a given distance from a given point, which is called the center; the given distance is the radius.

Insert $\begin{cases} \Gamma = \Gamma_r + j\Gamma_i \\ z_L = r_L + jx_L \end{cases}$ into $z_L = \frac{1+\Gamma}{1-\Gamma}$, then use

$$\text{Re(left side)} = \text{Re(right side)} \quad \Rightarrow \quad r_L = \frac{1 - \Gamma_r^2 - \Gamma_i^2}{(1 - \Gamma_r)^2 + \Gamma_i^2}$$

$$\Rightarrow \left(\Gamma_r - \frac{r_L}{1+r_L} \right)^2 + \Gamma_i^2 = \left(\frac{1}{1+r_L} \right)^2$$

This is the equation for the **locus** of all $\Gamma = \Gamma_r + j\Gamma_i$ that correspond to a given r_L .

The equation represents a circle centered at

$$\left(\frac{r_L}{1+r_L}, 0 \right)$$

and with radius

$$\frac{1}{1+r_L}$$

Notice that $\frac{r_L}{1+r_L} + \frac{1}{1+r_L} = 1$

So every such circle goes through the point (1, 0).

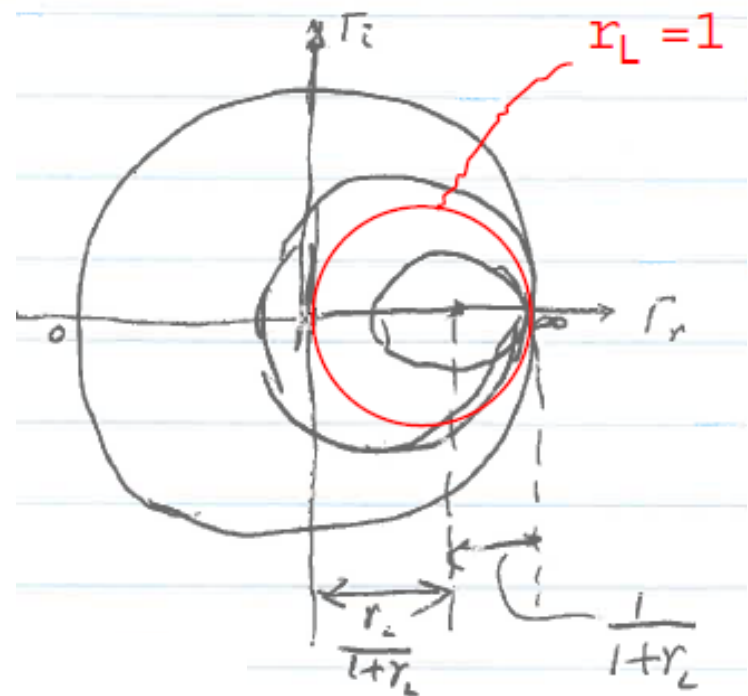

Each of these circles represent all $\Gamma = \Gamma_r + j\Gamma_i$ that correspond to a given r_L .

$$\left(\Gamma_r - \frac{r_L}{1+r_L}\right)^2 + \Gamma_i^2 = \left(\frac{1}{1+r_L}\right)^2$$

Every such circle goes through the point (1, 0).

Each circle centered at $\left(\frac{r_L}{1+r_L}, 0\right)$

with radius $\frac{1}{1+r_L}$

$r_L = 1 \implies$ center at (1/2, 0), radius = 1/2.

$r_L = 0 \implies$ center at (0, 0), radius = 1.

$$|\Gamma| = 1$$

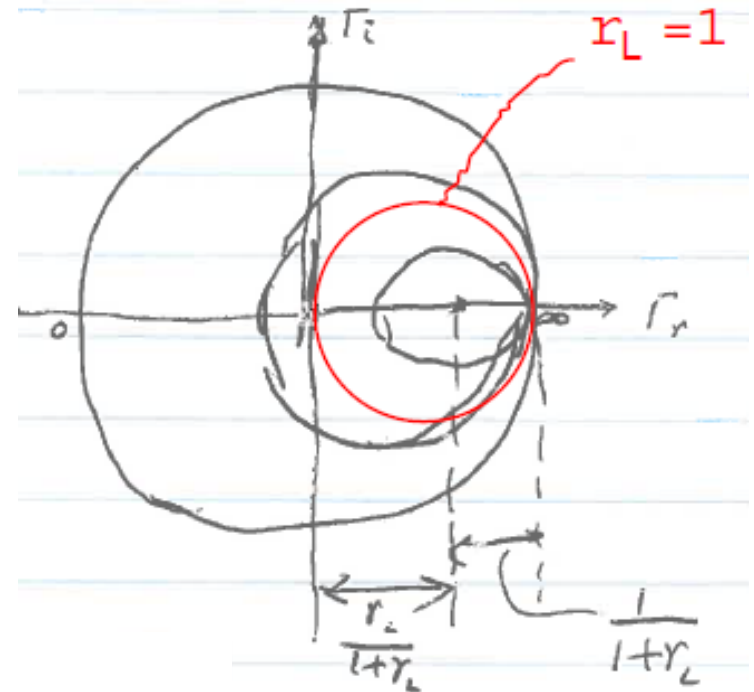

What kind of impedances correspond to this circle?

$r_L = \infty \implies$ center at (1, 0), radius = 0.

Insert $\begin{cases} \Gamma = \Gamma_r + j\Gamma_i \\ z_L = r_L + jx_L \end{cases}$ into $z_L = \frac{1+\Gamma}{1-\Gamma}$, then use

$$\text{Im(left side)} = \text{Im(right side)} \Rightarrow x_L = \frac{2\Gamma_i}{(1-\Gamma_r)^2 + \Gamma_i^2}$$

$$\Rightarrow (\Gamma_r - 1)^2 + \left(\Gamma_i - \frac{1}{x_L}\right)^2 = \left(\frac{1}{x_L}\right)^2$$

This is the equation for the **locus** of all $\Gamma = \Gamma_r + j\Gamma_i$ that correspond to a given x_L .

Each circle centered at $(1, \frac{1}{x_L})$

with radius $\frac{1}{|x_L|}$

Look at special cases $x_L = 0$,
 $x_L = \pm 1$, $x_L = \pm \infty$

You may drop the the subscript "L", since the Γ - z correspondence is general, not just the load.

Where is $(r = 1, x = 0)$?

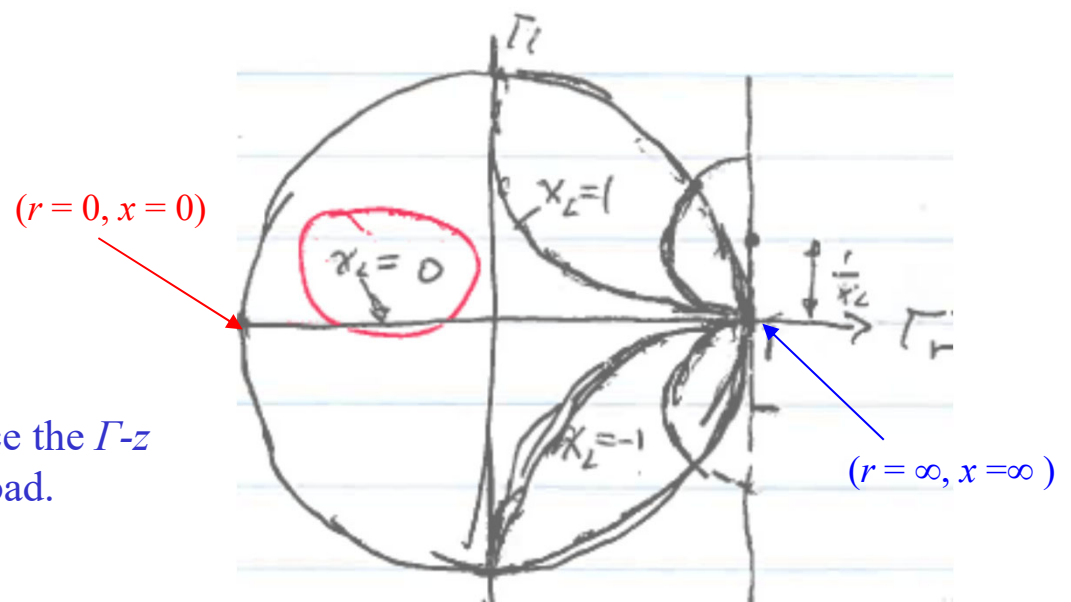

Plot circles of constant r and circles of constant x on the same chart, and you have the Smith Chart.

Given any $z = r + jx$, you can locate the intersection between circle r and circle x .

The intersection represents Γ .

Connect the intersection to origin. Measure length to get $|\Gamma|$ (with reference $|\Gamma| = 1$ for the big circle). Measure angle to get phase.

Signs for x are not labeled.

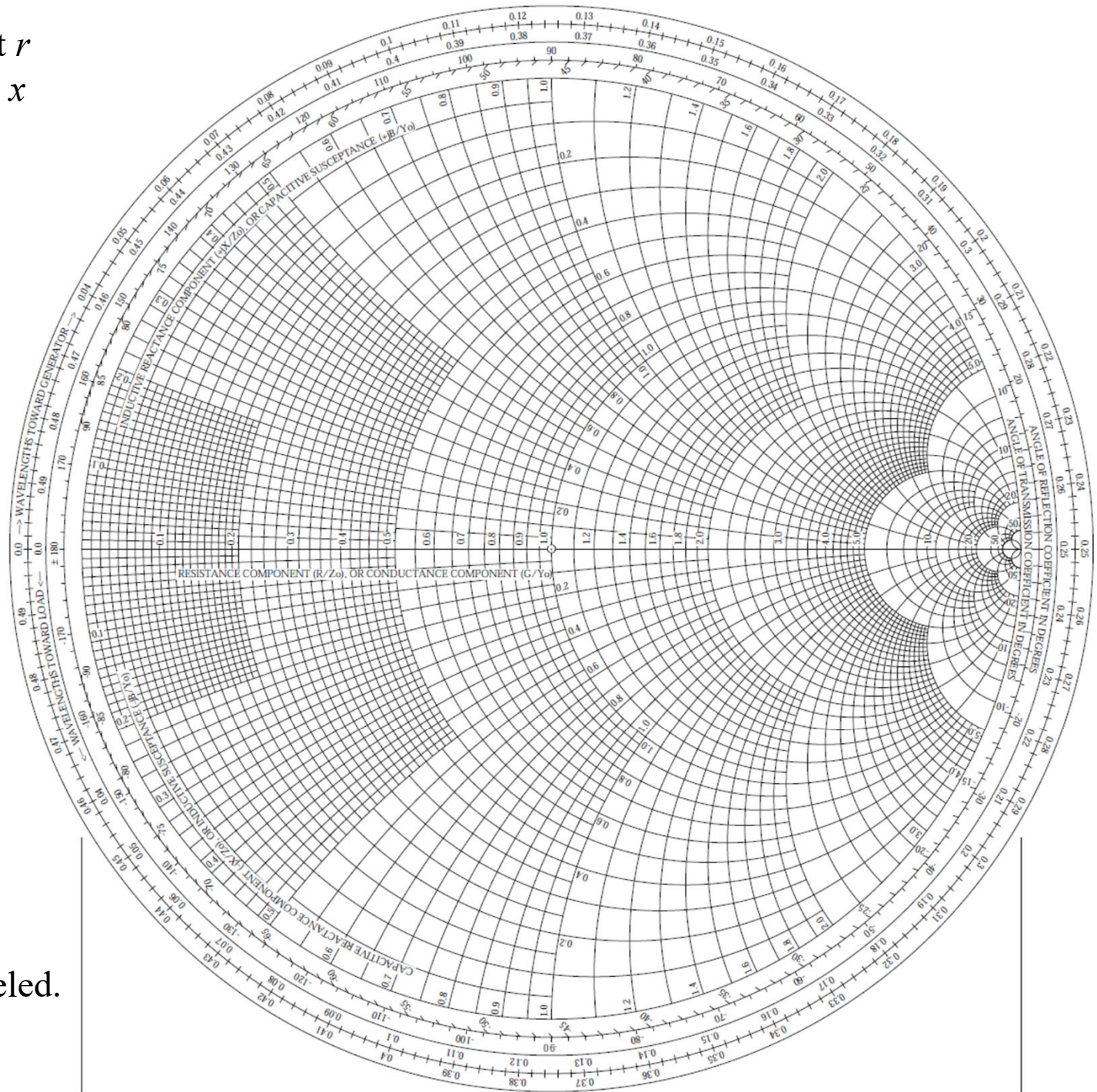

Let's have an exercise:

Find the Γ corresponding to a load $z_L = 2 - j$.

BTW, if $Z_0 = 50 \Omega$, what is Z_L ?

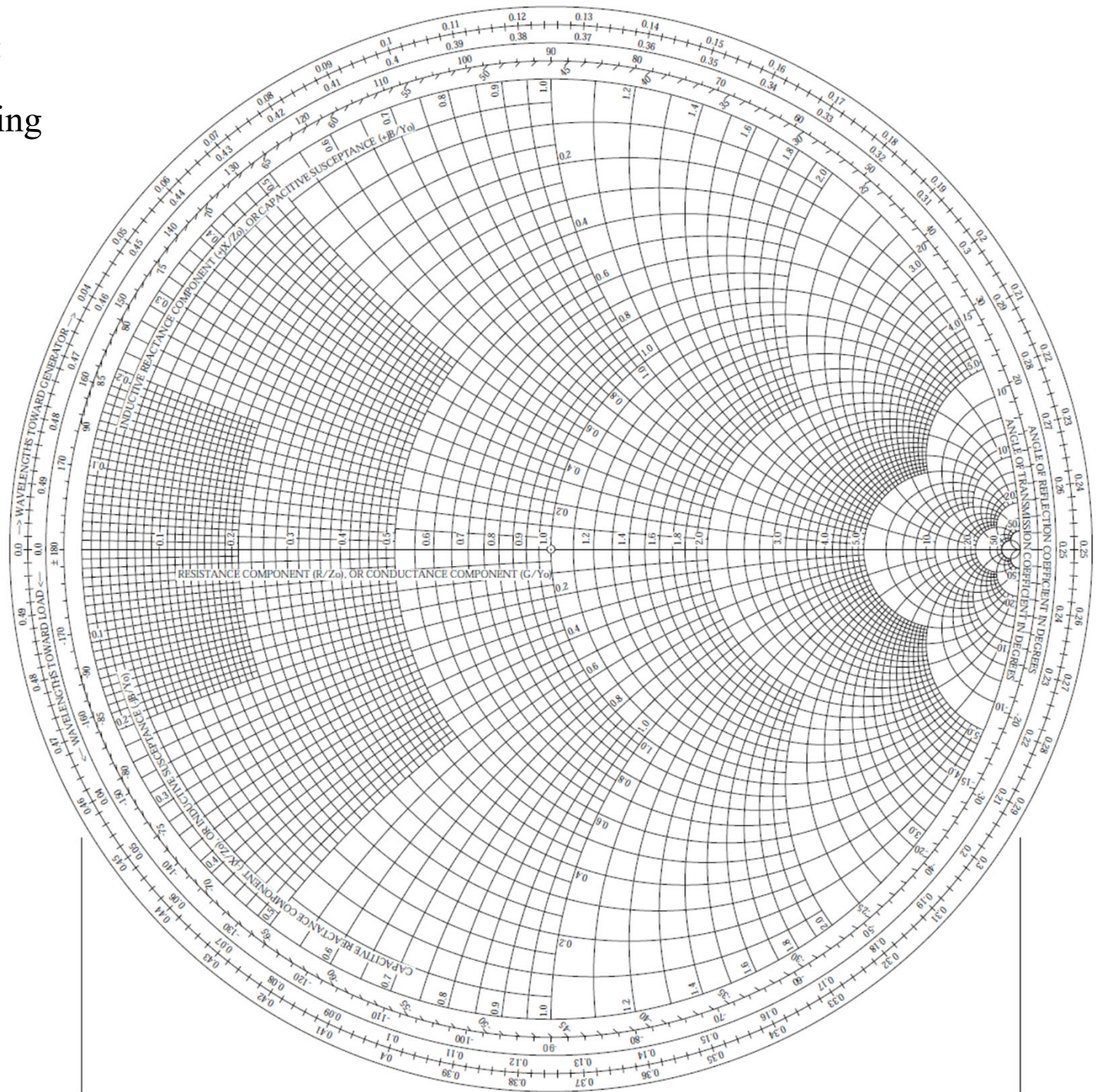

Let's have an exercise:

Find the Γ corresponding to a load $z_L = 2 - j$.

Locate the circle $r = 2$

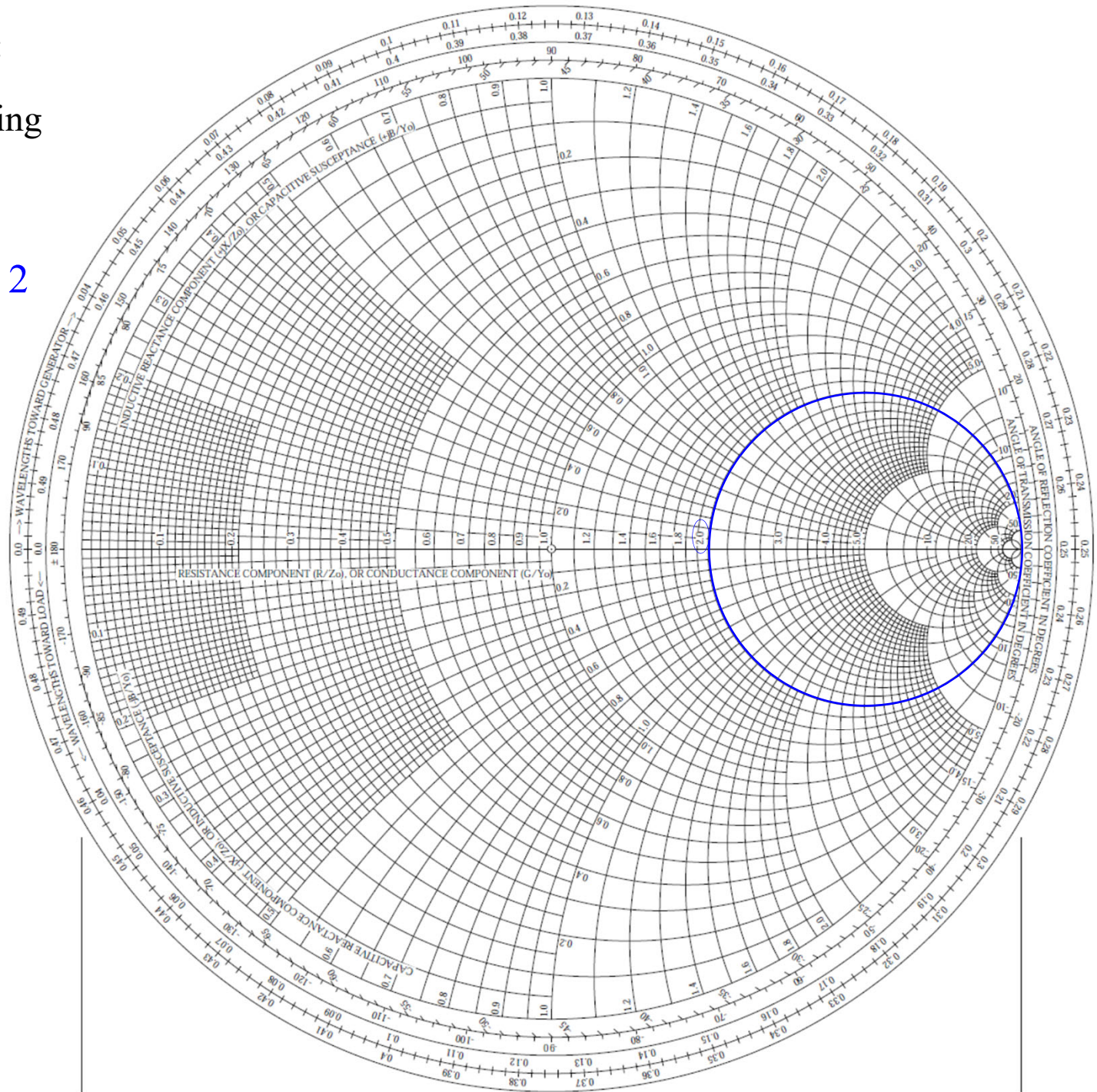

Let's have an exercise:

Find the Γ corresponding to a load $z_L = 2 - j$.

Locate the circle $x = -1$

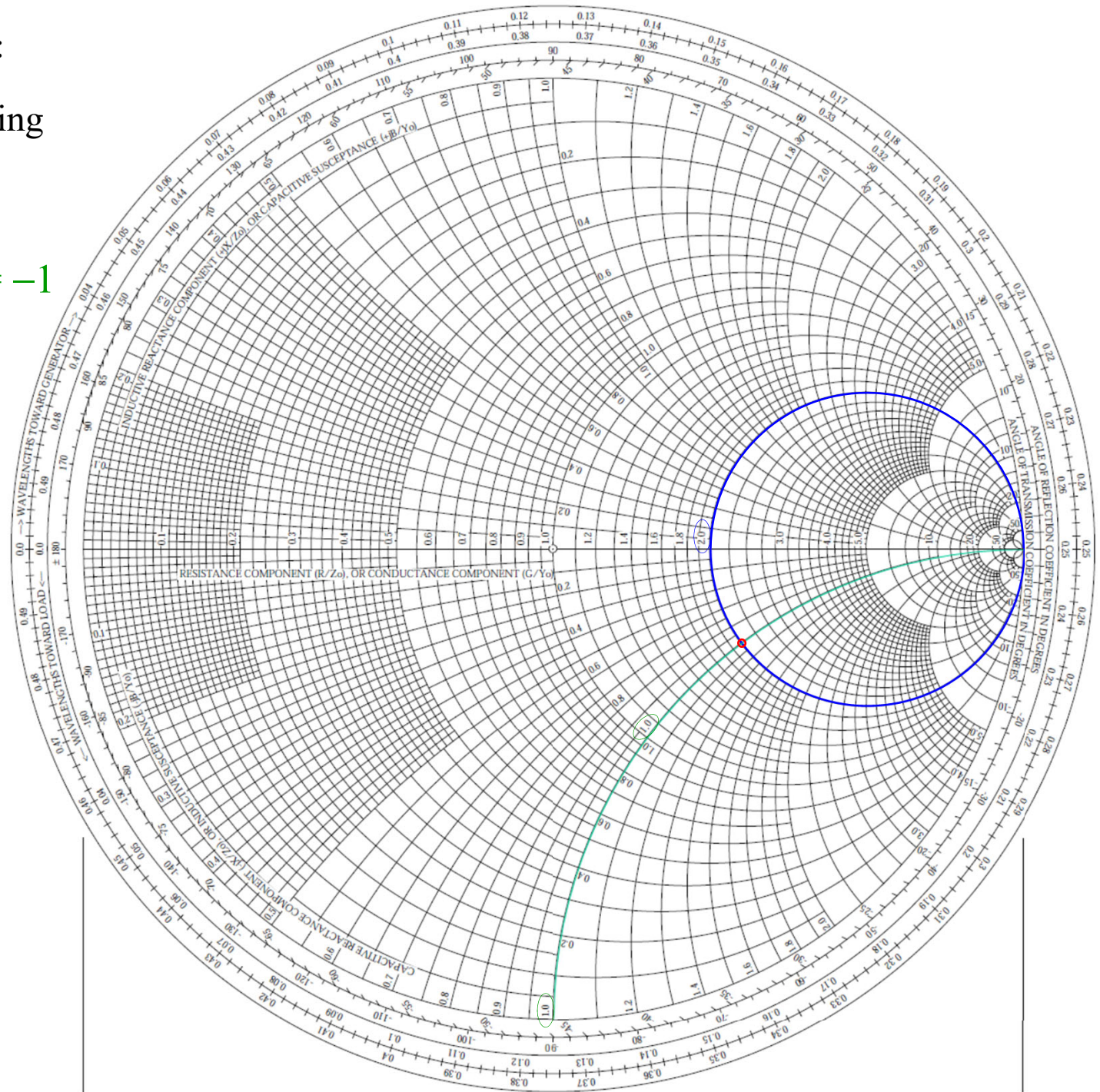

Find the Γ corresponding to a load $z_L = 2 - j$.

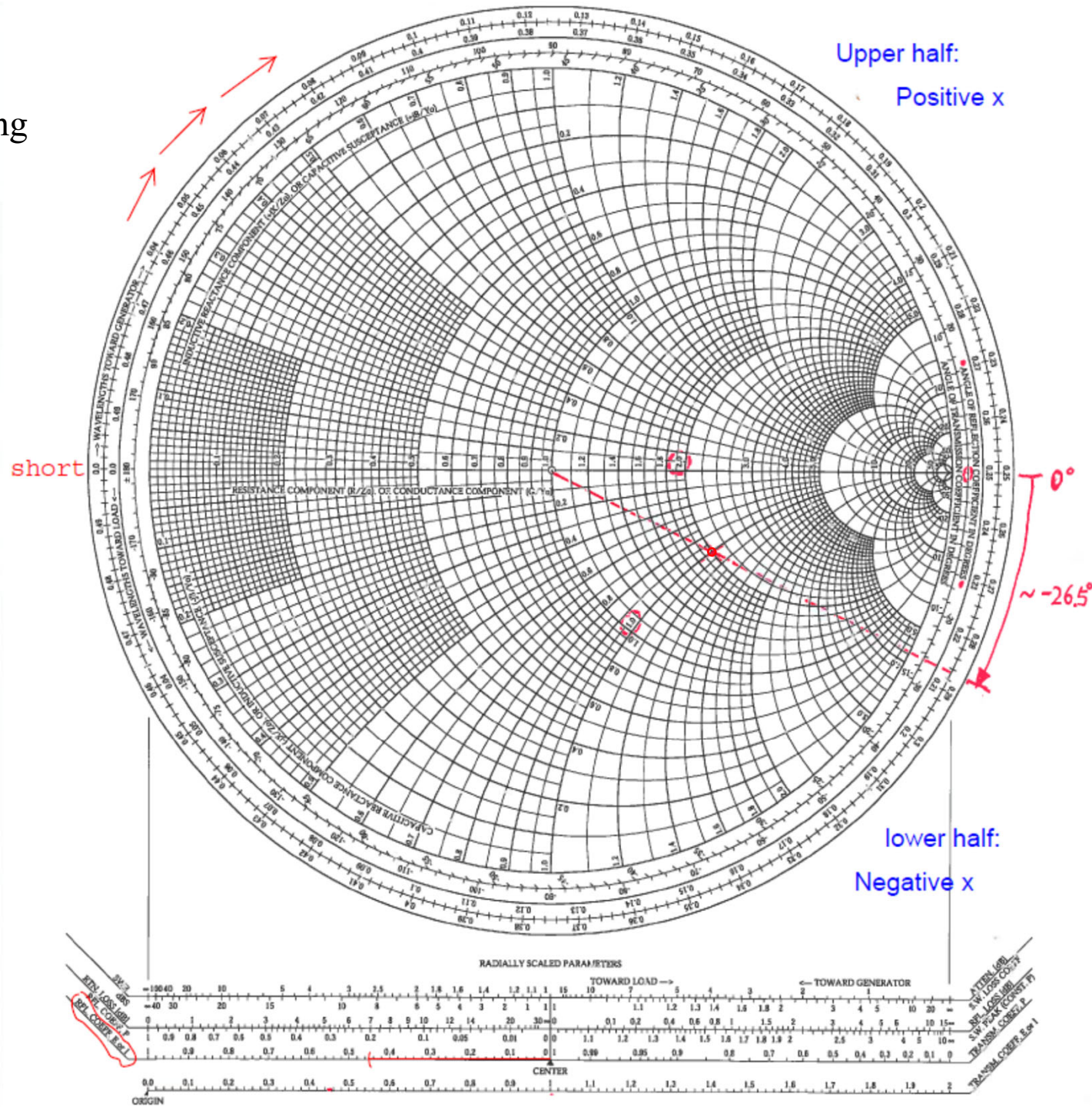

Answer:

$$|\Gamma| \sim 0.45 \quad \theta_r \sim -27^\circ$$

How: (not the only method; for your reference)

- Find the intersection of the $r_L = 2$ circle & the $x_L = -1$ circle
- Draw a straight line from origin to this intersection point, extend it beyond the $|\Gamma| = 1$ circle (a.k.a. the unit circle)
- Measure the distance between origin and the intersection point with regard to the radius of the unit circle, using the “RFL COEFF” bar at bottom – you get $|\Gamma|$
- Read the outer tick “ANGLE OF REFLECTION COEFFICIENT IN DEGREES” – you get θ_r

Notes:

- The $|\Gamma| = 1$ circle is the circle next to the inner scale
- The outer ticks of this inner scale stand for θ_r

What are the two sets of ticks on the outer scale?

Recall that $z(d) = \frac{1 + \Gamma_d}{1 - \Gamma_d}$ at distance d from the load,

just as $z_L = \frac{1 + \Gamma}{1 - \Gamma}$ at the load.

$$\Gamma_d = \Gamma e^{-2j\beta d}$$

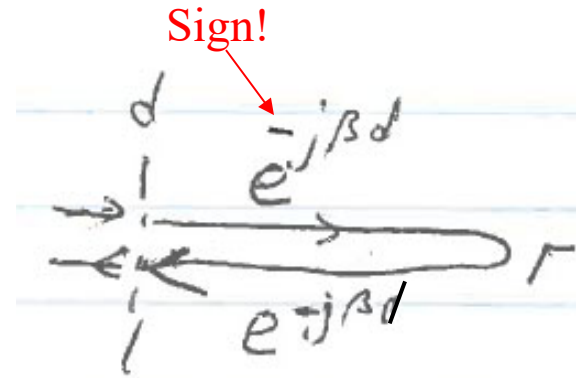

Γ_d is just phase-shifted by $-2\beta d$ from Γ .

Therefore, $|\Gamma_d| = |\Gamma|$. Just rotate from Γ by $2\beta d$ **clockwise**.

Moving away from load (towards generator) \iff Rotating clockwise

Moving away from load
(towards generator)

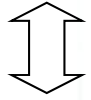

Rotating clockwise

short
 $\Gamma = -1$

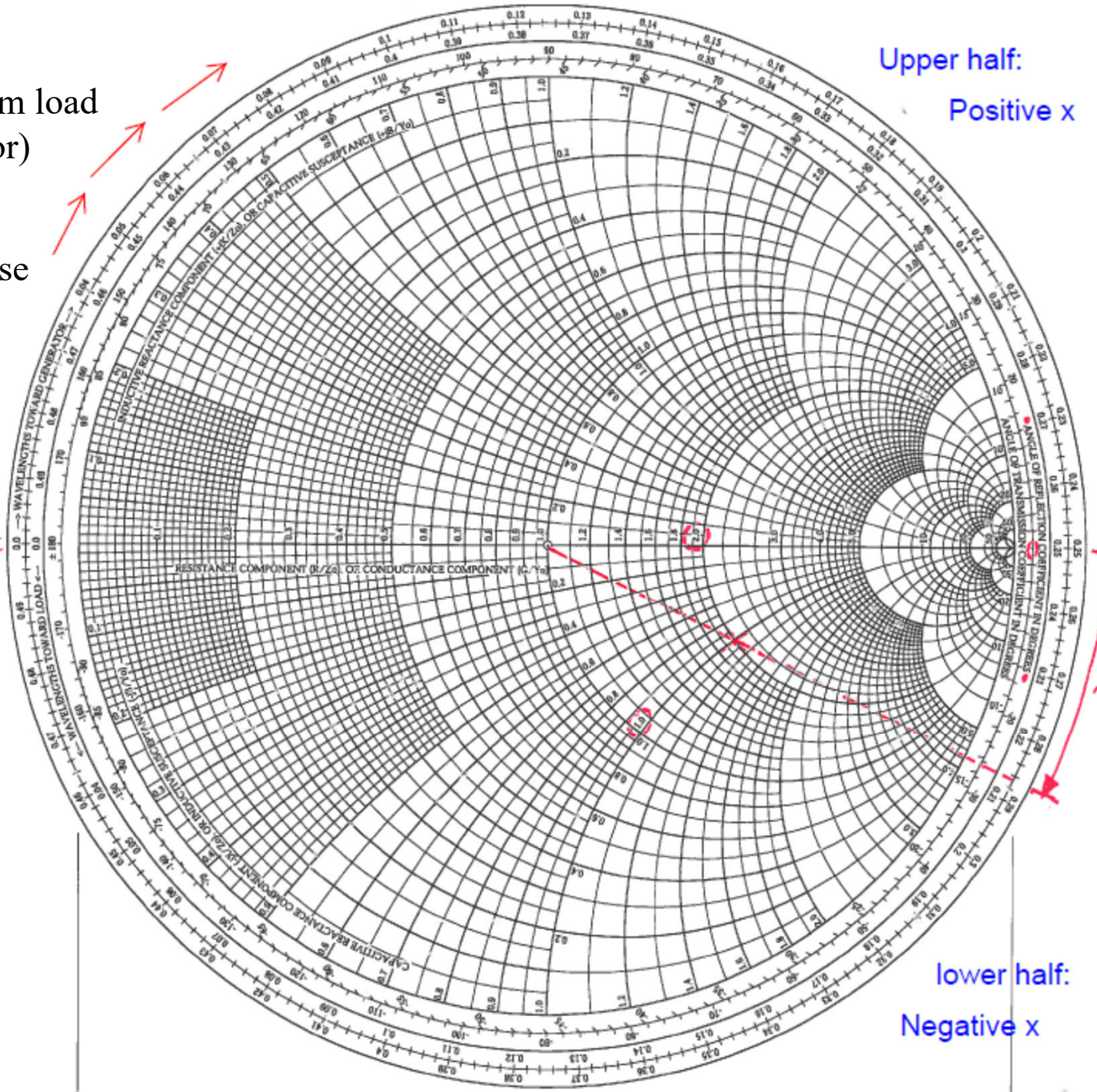

Upper half:
Positive x

lower half:
Negative x

0°
~ -26.5°

Same for $d + \Delta d$ from d :

$\Gamma_{d+\Delta d}$ is just phase-shifted by $-2\beta\Delta d$ from Γ_d .

Therefore, $|\Gamma_{d+\Delta d}| = |\Gamma_d|$. Just rotate from Γ_d by $2\beta\Delta d$ **clockwise**.

If $d = \frac{\lambda}{2}$, $2\beta d = 2\pi = 360^\circ$: one round!

$$\text{Recall } \beta = \frac{2\pi}{\lambda}$$

$$\Gamma_{\frac{\lambda}{2}} = \Gamma$$

Similarly,

$$\Gamma_{d+\frac{\lambda}{2}} = \Gamma_d$$

The outer set of ticks of the outer scale is distance d in λ 's towards the generator, i.e., away from the load.

The assumed load is a short. Therefore $d = 0.25\lambda$ for an open, corresponding to $\Gamma = +1$.

But an actual load can be anything. So take this scale to be relative.

Let's have another exercise.

Get the chart you used for the last example, where we found, for $z_L = 2 - j$,

$$|\Gamma| \sim 0.45 \quad \theta_r \sim -27^\circ$$

Now, find $z(d)$ for $d = 0.1\lambda$.

(See chart on next slide)

Extend the line we drew to cross the outer scale.
Read the outer ticks to get the offset distance “ d ”.

$$“d” = 0.287\lambda.$$

$$0.287 + 0.1 = 0.387$$

Go clockwise to “ d ” = 0.387λ .

Connect this point on the outermost scale to the origin.

Recall that $|\Gamma_d| = |\Gamma|$. So you get the Γ_d for $d = 0.1\lambda$.

Now read $z(d)$ from the chart.

The scale is relative.

Offset because the chart
assumes short.

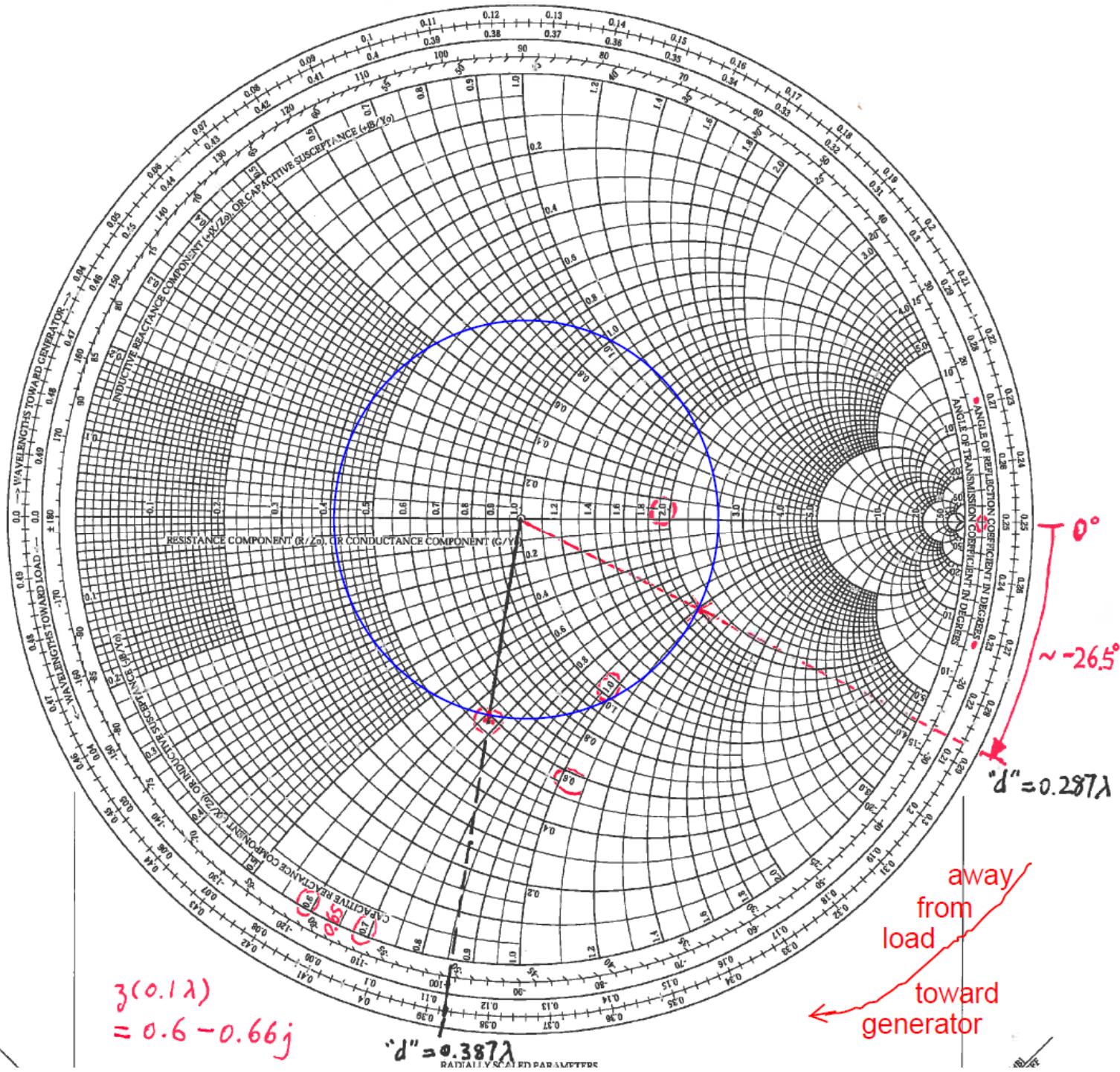

$3(0.12)$
 $= 0.6 - 0.66j$

$d'' = 0.387\lambda$
 RADIALLY SCALING PARAMETERS

away from load
 toward generator

Answer: $z(d) = z(0.1\lambda) = 0.6 - j0.66$.

(Question: What is $Z(d)$ if $Z_0 = 50 \Omega$?)

↑
Sign!

BTW, the **inner tick labels** of the outer scale are distance in wavelengths **towards the load**, i.e., away from the generator (source).

You may use either set of labels. Just remember that going away from the load on the transmission line is rotating clockwise on the chart. (**Why?**)

You just need to be consistent, and do the addition/subtraction right.

The smith chart was developed in 1939, when doing tedious algebra with complex numbers was a big deal.

Now, with computers, why do we still teach this tool here?

Recall that the SWR

$$S = \frac{|V|_{\max}}{|V|_{\min}} = \frac{1 + |\Gamma|}{1 - |\Gamma|}$$

So, a constant $|\Gamma|$ means a constant S . The blue circle we drew is called the constant-SWR circle.

It's just a constant- $|\Gamma|$ circle.

Hyphen, not minus/negative

The SWR is a property of the transmission line/load system.

When we say “rotating” on the chart, we mean moving on the constant-SWR circle.

Going away from the load on the transmission line is moving clockwise on the constant-SWR circle.

Let's have one more hands-on exercise (using the chart we used).

We had a load $z_L = 2 - j$, and found $|\Gamma| \sim 0.45$ $\theta_r \sim -27^\circ$

Then we moved a tenth of a wavelength and found $z(0.1\lambda) = 0.6 - j0.66$.

We moved on a constant- $|\Gamma|$, or constant-SWR, circle. You can easily calculate S by

$$S = \frac{|\tilde{V}|_{\max}}{|\tilde{V}|_{\min}} = \frac{1 + |\Gamma|}{1 - |\Gamma|}$$

You may also graphically read from the chart.

We now move further, and hit the horizontal axis.

Recall that on this axis, $x(d) = 0$, and we have a minimum, i.e. $2\beta d - \theta_r = \pi$

Find $d = d_{\min}$

Recall the slotted line.

Now, moving further clockwise on the constant-SWR circle (i.e., away from the load or towards the generator), we will hit the horizontal axis again.

How much further have we moved from d_{\min} to reach this point?

This is a maximum. Also purely resistive. $2\beta d - \theta_r = 2\pi$

Find this $d = d_{\max}$

$$d_{max} = 0.213\lambda + 0.25\lambda = 0.463\lambda$$

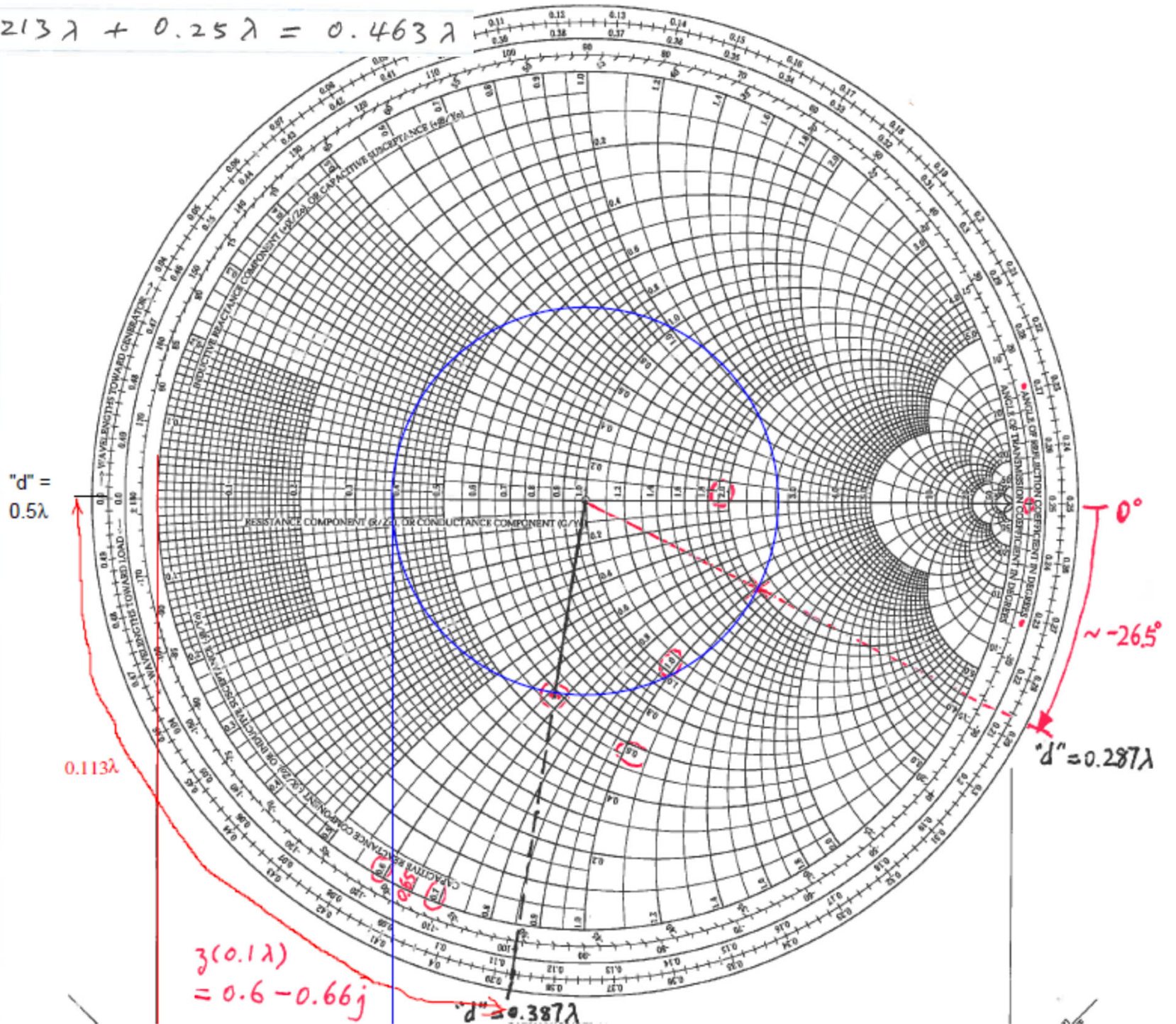

pp. 93
Fig. 2-27

(6/E)

pp. 94 in 7/E

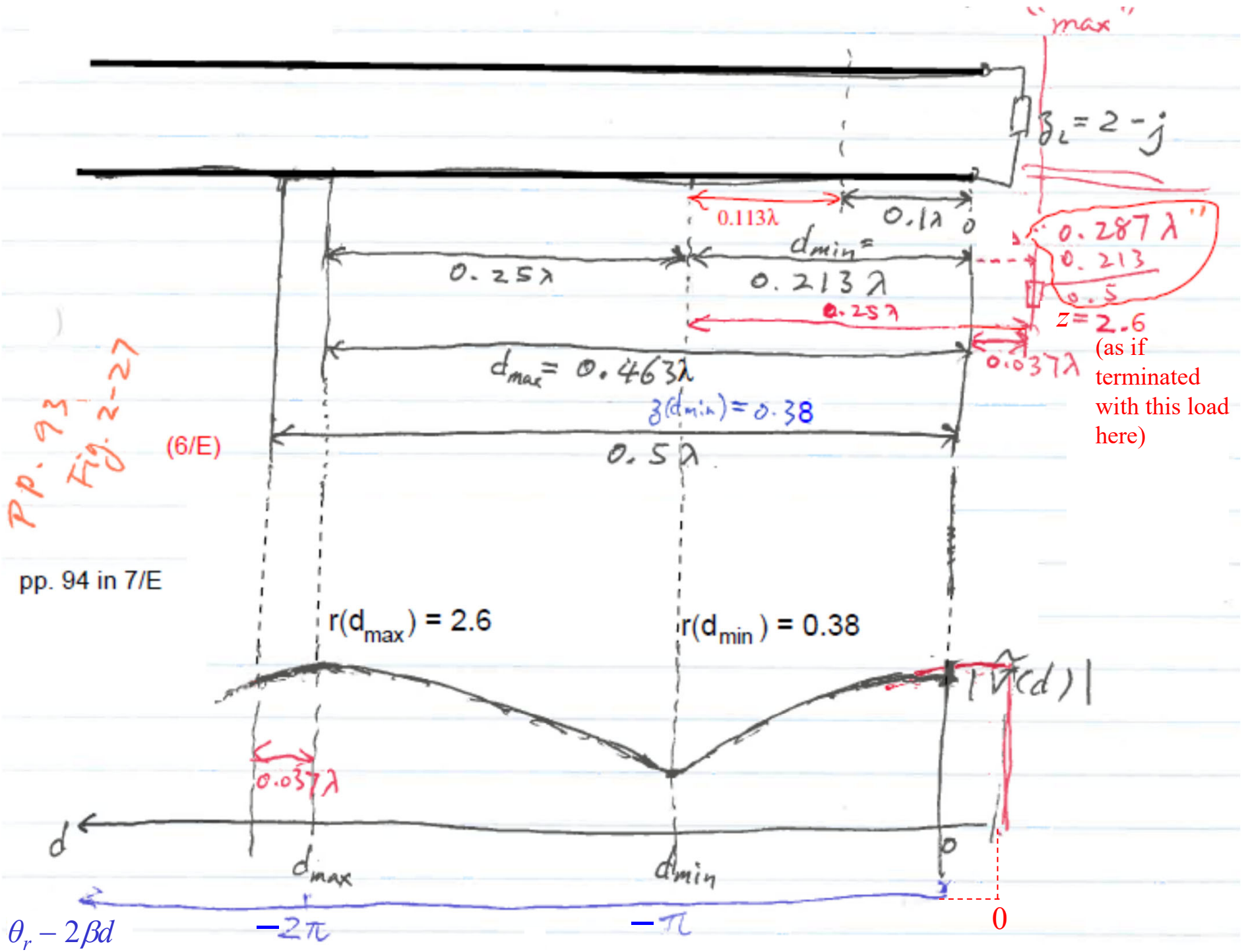

You can move along the constant-SWR circle round and round.

One round is $2\pi = 360^\circ$, or $\lambda/2$.

$|\tilde{V}(d)|$ is periodic.

Half a round is $\pi = 180^\circ$, or $\lambda/4$.

The maximum is a quarter wavelength away from the adjacent minimum.

At a minimum or a maximum, $x(d_{min}) = 0$ or $x(d_{max}) = 0$

Purely resistive.

If you have a purely resistive $z(d)$, you must have either a maximum or minimum,

At a minimum, the most destructive, $|\Gamma| < 0$

At a maximum, the most constructive, $|\Gamma| > 0$

[Review textbook Section 2-10. Finish Homework 4 Problems 1-3](#)

Smith Chart for $z \leftrightarrow \Gamma$ Mapping: A Recap

- Each point ^(inside) within the $|\Gamma| = 1$ circle represents a Γ , which uniquely corresponds to a $z = r + jx$
- One family of circles, each the locus of all Γ corresponding to a constant r
- One family of circles, each the locus of all Γ corresponding to a constant x
- Moving along the transmission line away from the load (i.e. towards the generator) is equivalent to moving along a constant-SWR circle (i.e. constant- $|\Gamma|$ circle) clockwise
- The chart we use assumes a short at the load, corresponding to $\Gamma = -1 = 1 \angle 180^\circ$, but that doesn't matter. Take the scales as relative.