

Impedance Matching

Generally, $Z_L = R_L + jX_L$, $X_L \neq 0$. You need to “turn two knobs” to achieve match.

Example



This time, we do not want to cut the line to insert a matching network. Instead, we tap something at some location to achieve matching. Therefore, we work with admittance.

First, locate this load on the chart.

Then, find y_L using the chart.

$$z_L = 0.5 - j$$

$$y_L = 0.4 + 0.8j$$

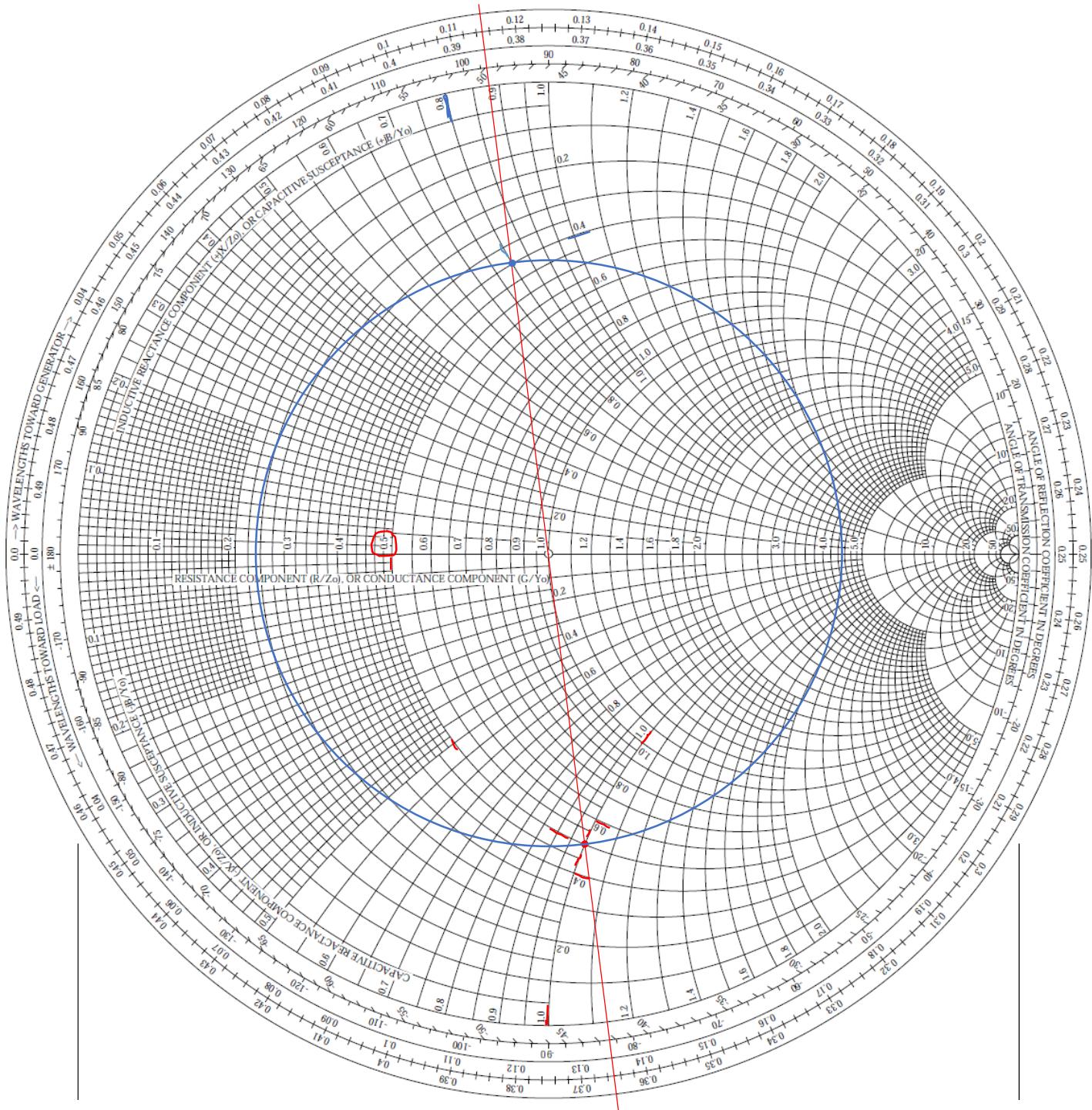

$$z_L = 0.5 - j \quad y_L = 0.4 + 0.8j$$

Move away from the load, i.e., along the constant-SWR circle clockwise.

We will hit this circle:

$$g = 1$$

When we use the chart for $z \leftrightarrow \Gamma$ mapping, we called [this circle](#) the $r = 1$ circle.

The Smith chart is whichever you consider it to be (a z -chart or a y -chart).

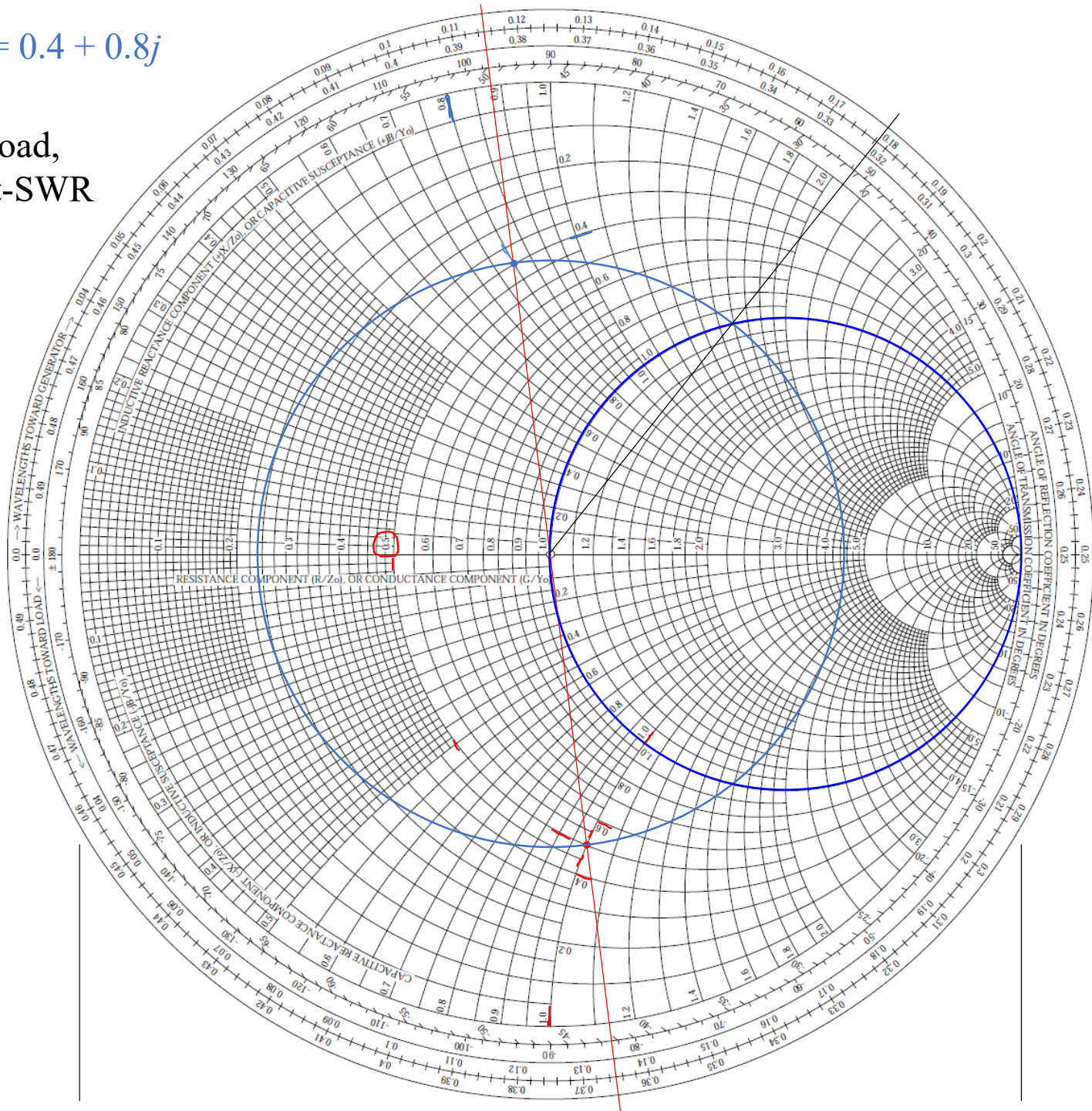

$$z_L = 0.5 - j \quad y_L = 0.4 + 0.8j$$

Move away from the load, i.e., along the constant-SWR circle clockwise.

We will hit this circle:

$$g = 1$$

On this circle, $y = 1 + jb$, i.e., $Y = Y_0 + jB$

The real part (conductance) is already matched to Y_0 .

If we can somehow cancel the jB part, we are done.

Now, read one of the two sets of ticks of the outer scale.

How far do we need to move to reach this point?

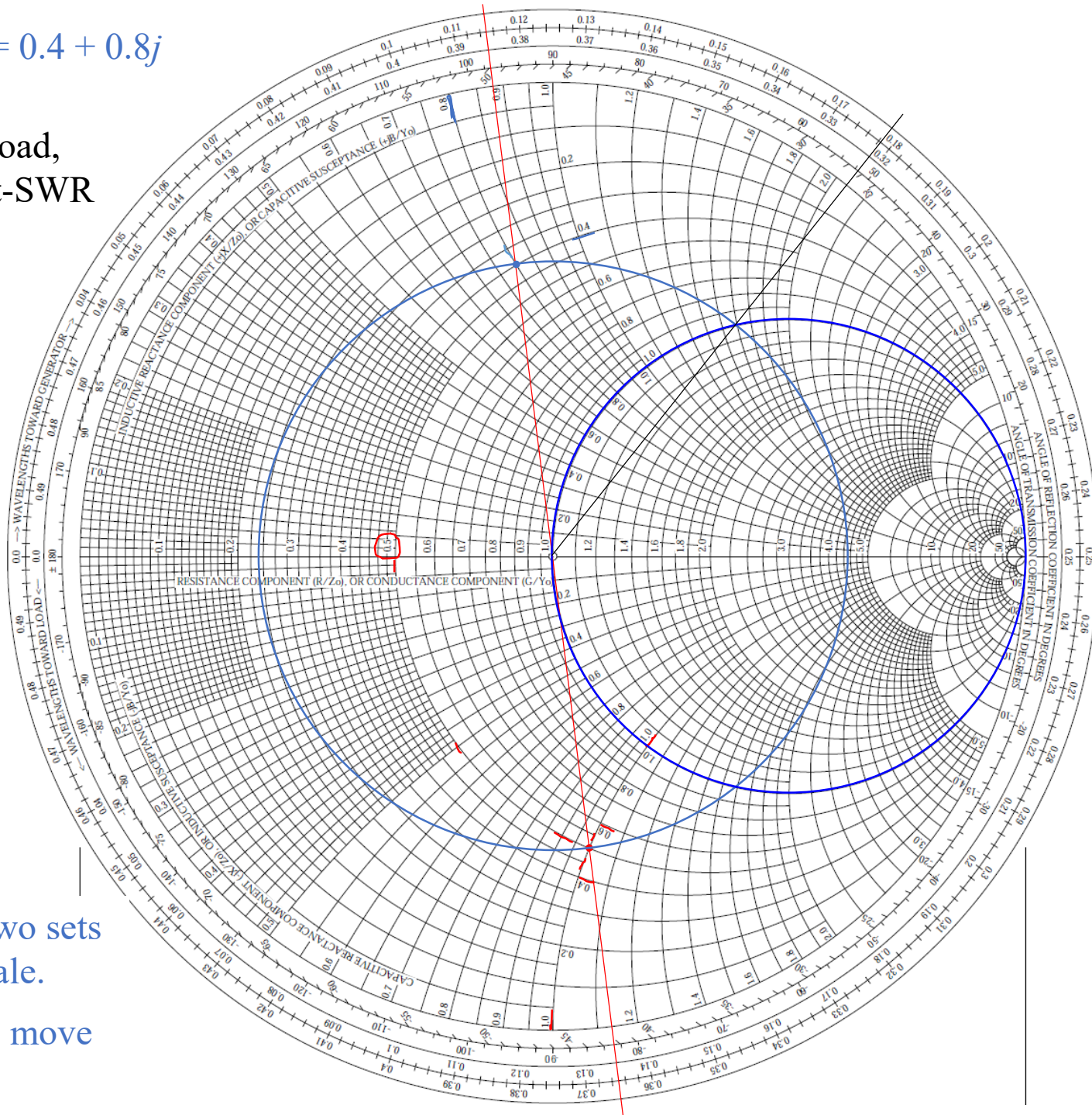

$$z_L = 0.5 - j \quad y_L = 0.4 + 0.8j$$

On this circle, $g = 1$

$$y = 1 + jb, \text{ i.e.,} \\ Y = Y_0 + jB$$

The real part
(conductance) is
already matched to Y_0 .

If we can somehow
cancel the jB part, we
are done.

Distance we need to
move to hit this circle:

$$0.178\lambda - 0.115\lambda = 0.063\lambda$$

Normalized admittance at
the cross point:

$$y(0.063\lambda) = 1 + 1.58j$$

$$\text{Therefore, } Y(0.063\lambda) = Y_0 + j1.58Y_0$$

Is the susceptance inductive or capacitive?

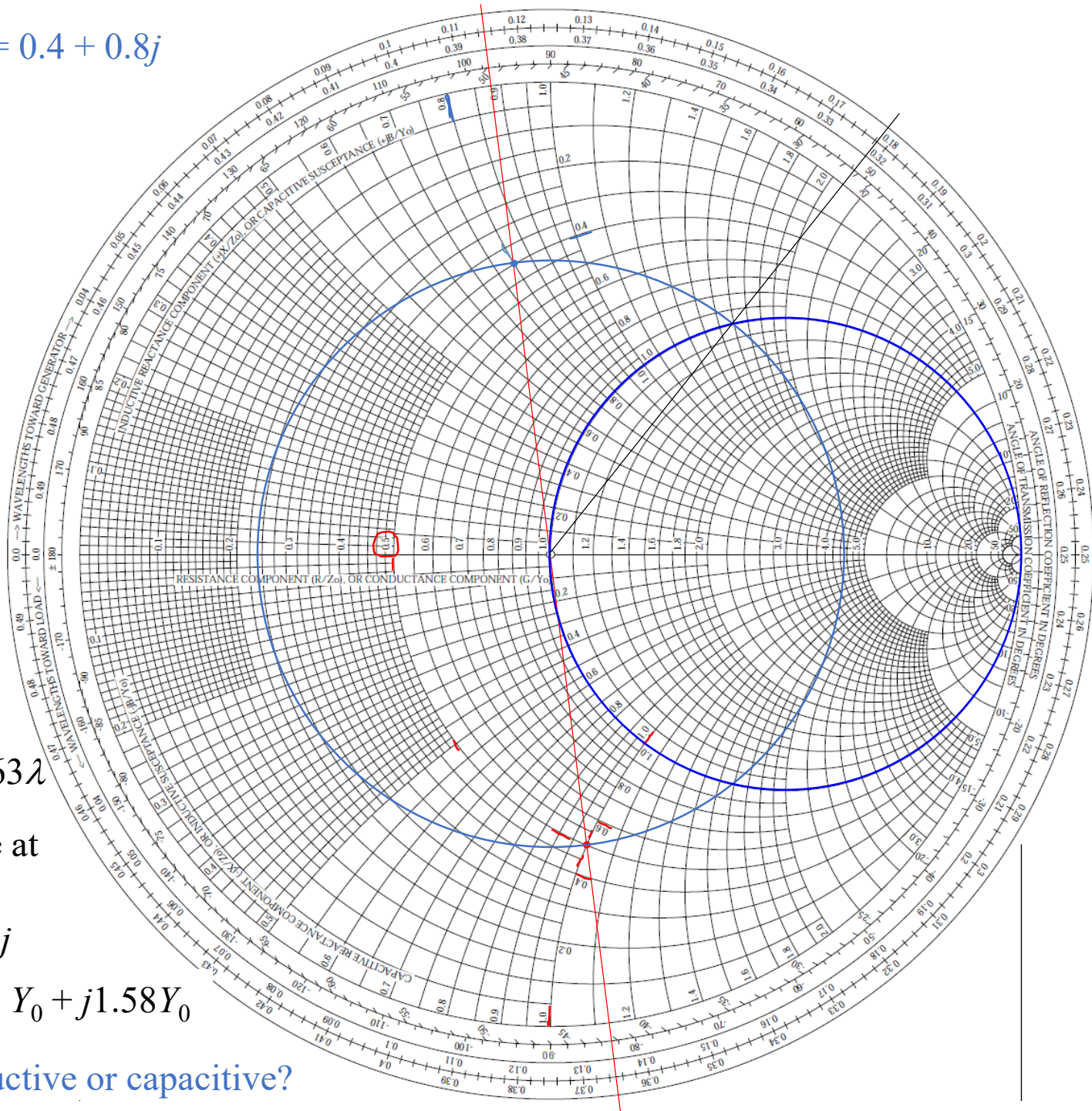

Let's keep in mind that we are dealing with admittance!

For a capacitor C , $Y = j\omega C$

For an inductor L , $Y = \frac{1}{j\omega L} = -j\frac{1}{\omega L}$

So, the susceptance is capacitive. [How to cancel it?](#)

Class ended here on Thu 3/4/2021.

Impedance Matching Using Lumped Elements

Let's say $Z_0 = 50 \Omega$. Then the susceptance we need to cancel is $1.58 \times (1/50) \Omega^{-1}$.

We can use an inductor L to cancel it: $\frac{1}{\omega L} = 1.58 \times \frac{1}{50} \Omega^{-1} \implies L = (50 \Omega) / (1.58 \omega)$

Given the frequency, we can calculate the needed L .

To keep in mind:

- Any matching is frequency specific
- Not just L , but also distance d , because d is in terms of λ , which is frequency dependent
- We are dealing with admittance. The impedance is the diametrical point
- If you want to find out what the SWR is at d (where you put your inductor) in absence of the inductor, what do you do? (Or, how do you find $z(d)$ of the line in absence of the inductor?) – Refer to the chart.

[Review textbook Section 2-11.1](#)

You can also use a capacitor to achieve matching. See Smith chart on next slide.

You rotate further (i.e., moving further along the constant-SWR circle), and you will hit the $g = 1$ circle again.

That means, you move further along the transmission line, until you have $G = Y_0$.

Apparently, this point is symmetric with that point of the last solution (where you used an inductor).

So, the admittance here (of the main branch) is $y(d) = 1 - 1.58j$

$$d = 0.322\lambda - 0.115\lambda = 0.207\lambda$$

Again, we are dealing with admittance (the impedance is the point diametrical to the admittance).

So, the reactive part of $y(d)$ is inductive.

You need a capacitor C to cancel it.

If $Z_0 = 50 \Omega$,

$$\omega C = 1.58 \times (1/50) \Omega^{-1}$$

$$C = (1.58/\omega) \times (1/50) \Omega^{-1}$$

Again, matching is frequency specific.

$$z_L = 0.5 - j$$

$$y_L = 0.4 + 0.8j$$

Solution 1

On this circle, $g = 1$

$$y = 1 + jb, \text{ i.e.,} \\ Y = Y_0 + jB$$

The real part
(conductance) is
already matched to Y_0 .

If we can somehow
cancel the jB part, we
are done.

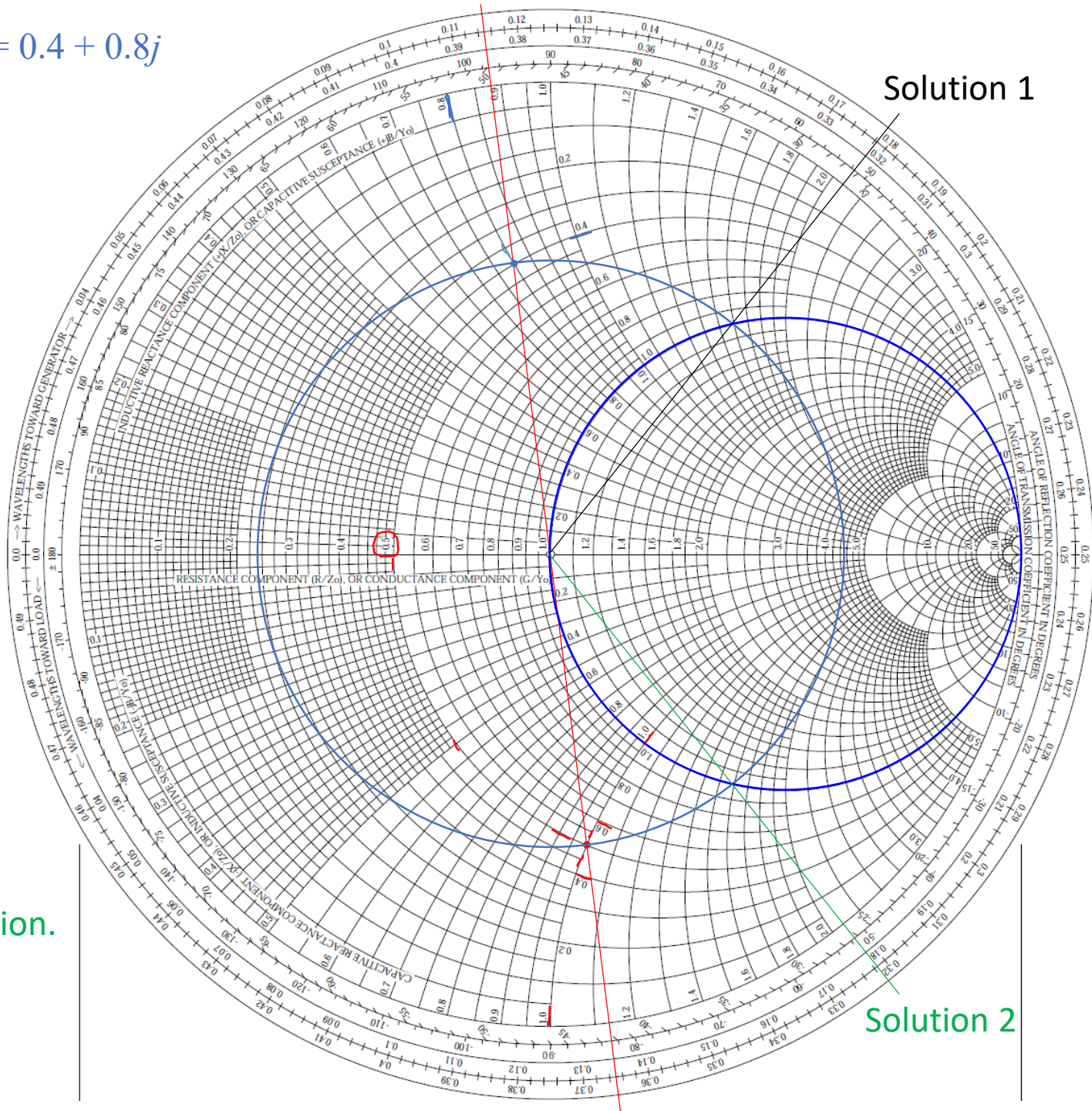

Solution 2

There is a second solution.

To keep in mind:

Here, we deal with admittance. The circle we call the $r = 1$ circle (when talking about impedance) is now the “ $g = 1$ ” circle.

However, if you are talking about impedance (i.e. using the Smith chart as the “z-chart,” the $g = 1$ circle is the green circle:

Each point on this circle is diametrical to a point on the “ $g = 1$ ” circle of the “y-chart.” See chart on next slide.

Carefully review textbook Section 2-11 overview and 2-11.1, Problems 4 & 5 of HW5

Questions: Where is the “ $r = 1$ ” circle on the y-chart?
Where is the “ $g = 1$ ” circle on the z-chart?

In the lab, you will use the “network analyzer,” which measures impedance and displays it on the Smith Chart (as the z-chart).

But you deal with admittance, because you will connect something in parallel with the main branch. You need to first get $z(d)$ onto the $g = 1$ circle (on the z-chart). (Where is it?)

To help you, the TAs cover the screen with a transparent sheet on which the $g = 1$ circle is printed.

$$z_L = 0.5 - j \quad y_L = 0.4 + 0.8j$$

On this circle, $g = 1$

$$y = 1 + jb, \text{ i.e.,}$$

$$Y = Y_0 + jB$$

$$d = 0.178\lambda - 0.115\lambda \\ = 0.063\lambda$$

$$y(d) = 1 + 1.58j$$

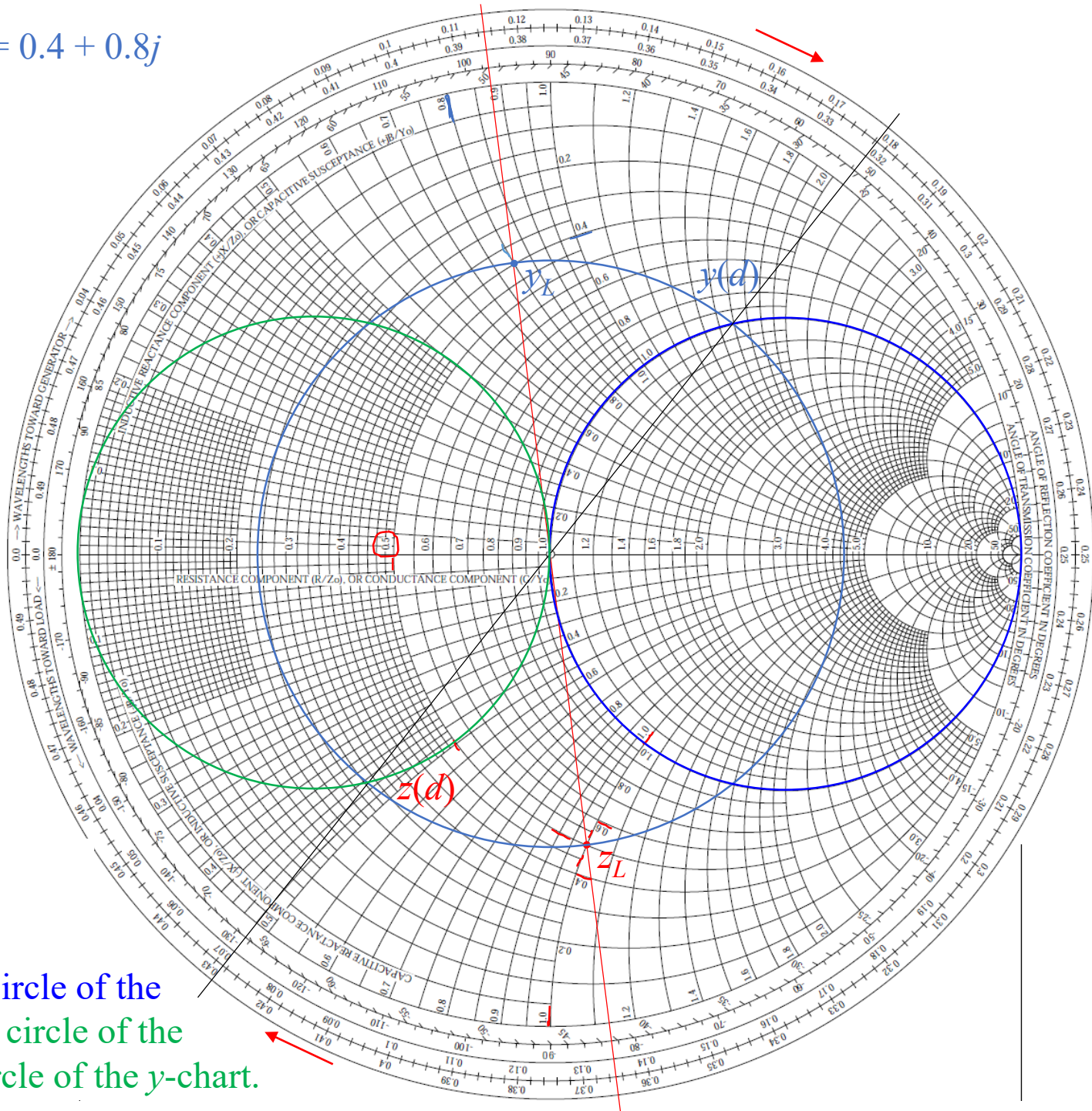

When $y(d)$ is on $g = 1$ circle of the y -chart, $z(d)$ is on $g = 1$ circle of the z -chart, i.e. the $r = 1$ circle of the y -chart.

Single-Stub Matching

We just showed “lumped element matching.”

But the desired lumped element may not be available, esp. at very high frequencies.

What can we do?

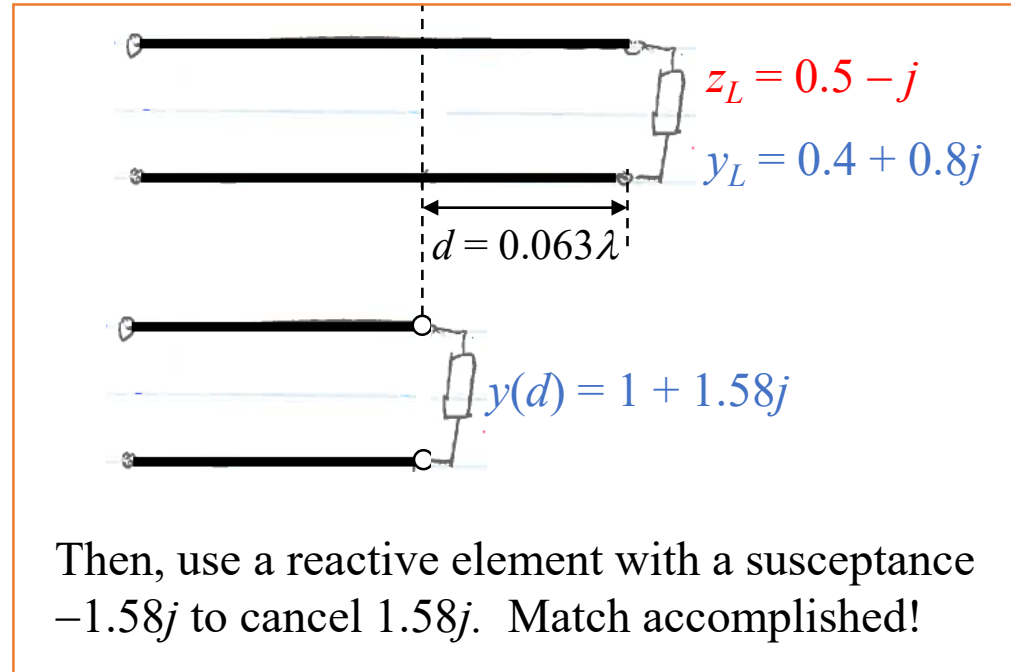

Single-Stub Matching

We just showed “lumped element matching.”

But the desired lumped element may not be available, esp. at very high frequencies.

What can we do?

Recall that

- we can make any arbitrary reactance out of a transmission line terminated in a short circuit
- just by adjusting the length l

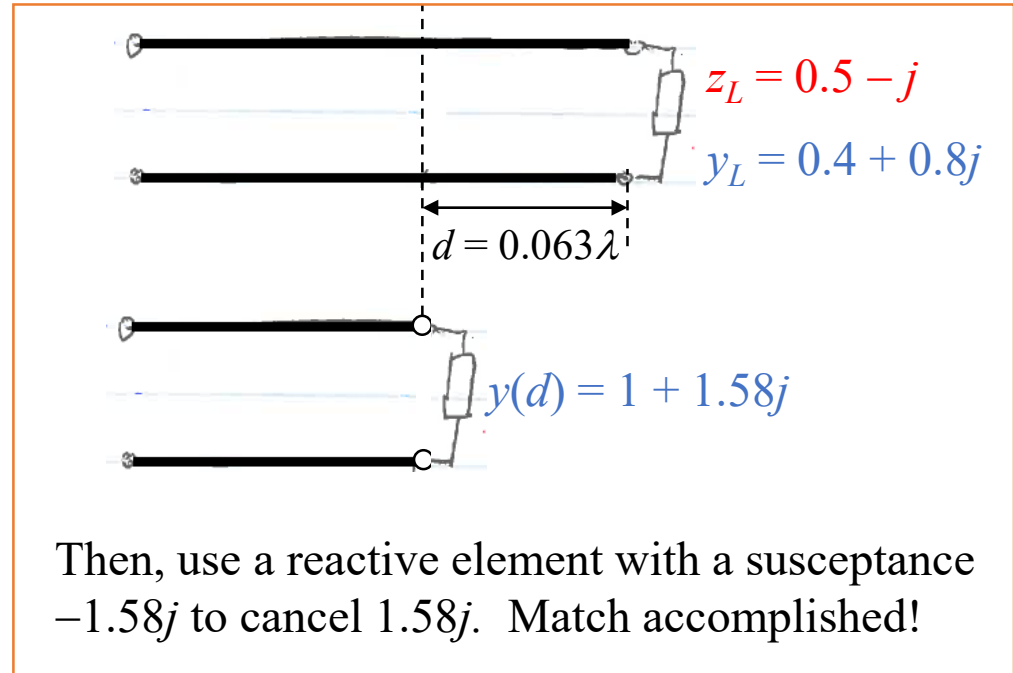

So, use a shorted line in place of the lumped reactive element.

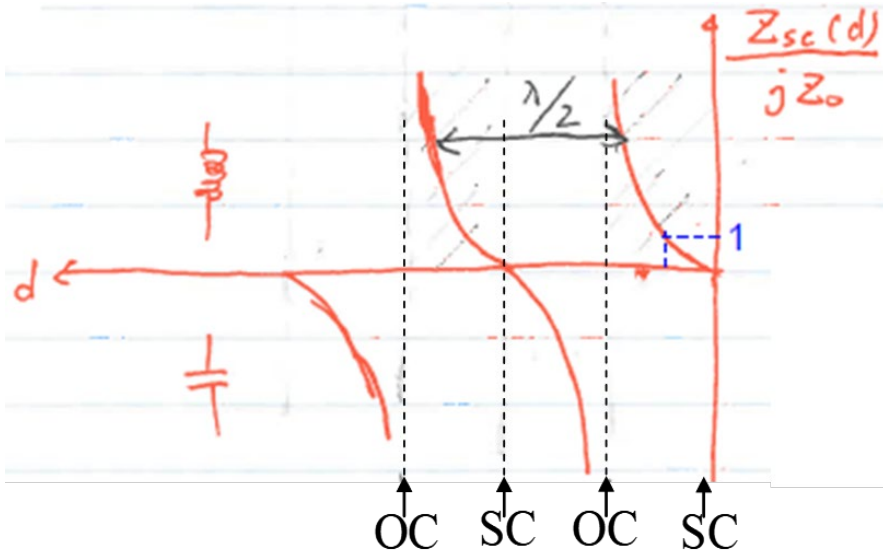
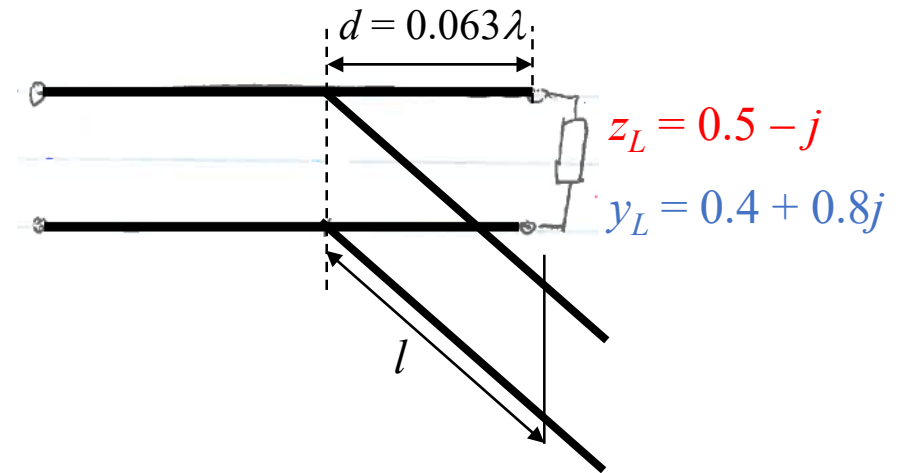

Use a shorted line in place of the lumped reactive element.

The shorted line is called a “stub.”

Thus the method “single-stub matching.”

For the main branch, the equivalent impedance at a distance d from the load is $y(d) = 1 + 1.58j$.

We just need to adjust l so that $y_{\text{stub}} = -1.58j$.

We can do that with the Smith chart, as the y -chart.

Why y -chart?

Locate the point on the y -chart corresponding to the short circuit.

Where?

Move from there along the constant-SWR circle that corresponds to purely reactive impedance values.

Which circle?

Reach the point $y_{\text{stub}} = -1.58j$. Read the chart to find l .

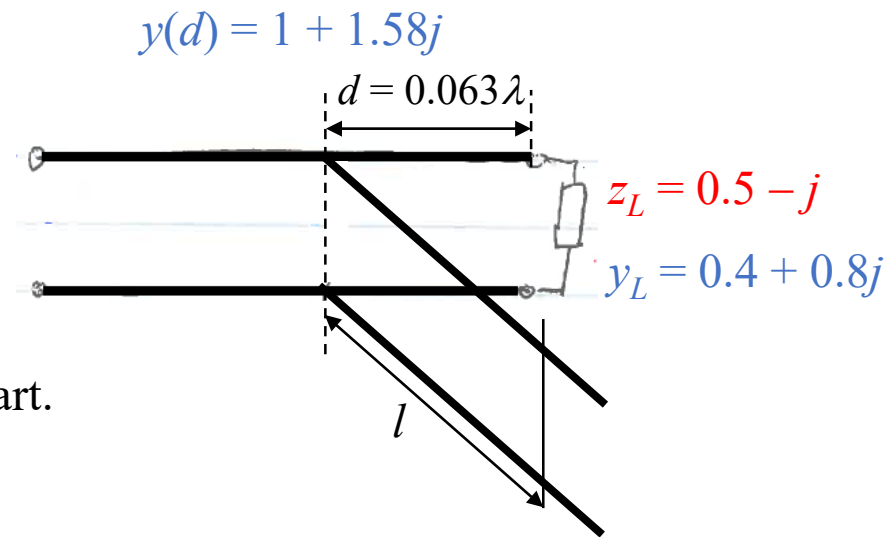

- The point on the **y-chart** corresponding to the **short circuit**.

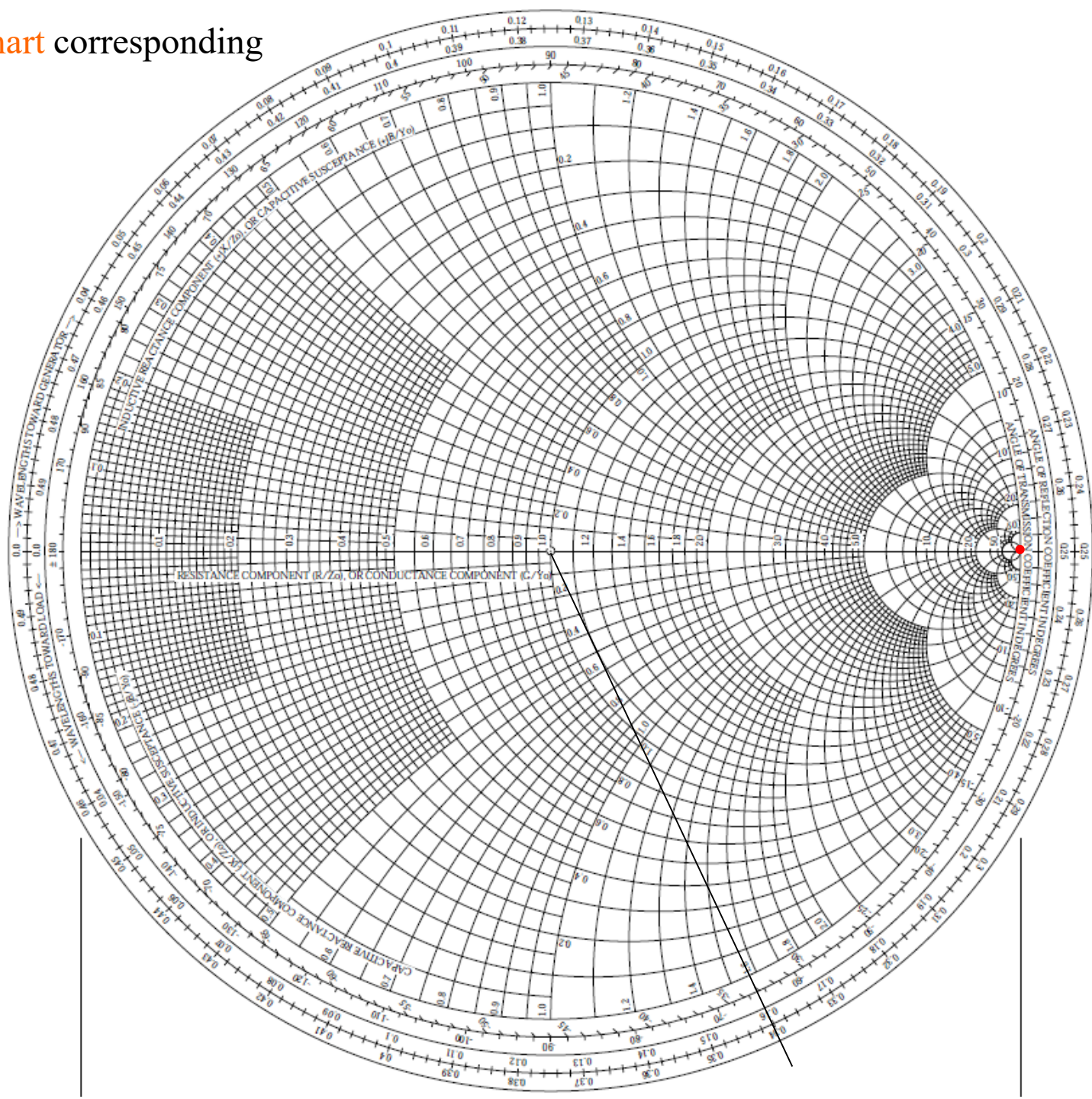

$$y_{\text{stub}} = -1.58j$$

$$y_{\text{stub}} = -1.58j$$

$$l = 0.34\lambda - 0.25\lambda = 0.09\lambda$$

or

$$l = 0.25\lambda - 0.16\lambda = 0.09\lambda$$

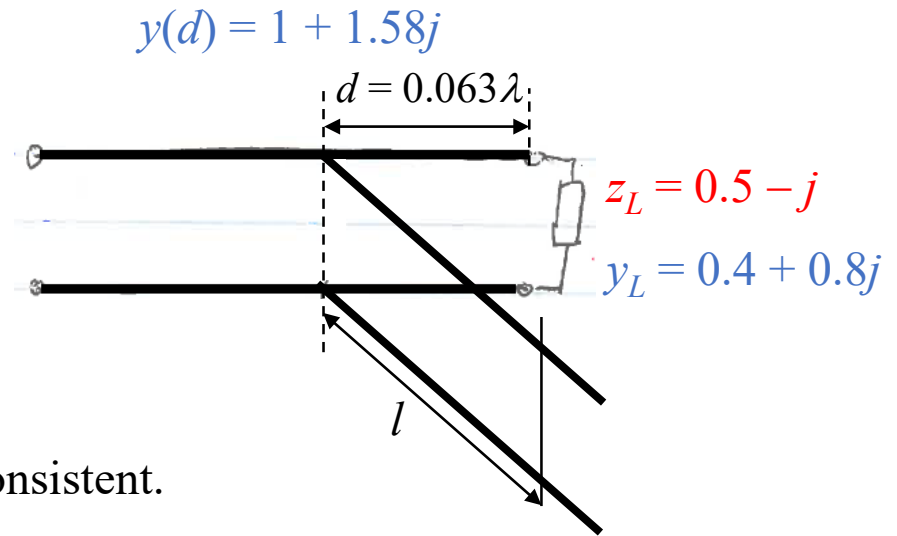

We may use either scale; just need to be consistent.

Recall that there is a second solution: at a larger distance d ,
 $y(d) = 1 - 1.58j$.

At that d , you may use a stub with a different l to cancel that $jb(d) = -1.58j$.

Work out the second solution on your own.

Review textbook Section 2-11.2. Finish HW5.

To “tap” the stub onto the main line may not be as convenient as it sounds.

You need Tees.

Not that convenient to adjust d .

Therefore the “**double-stub**” method was developed.

We need to adjust two parameters to get a match.

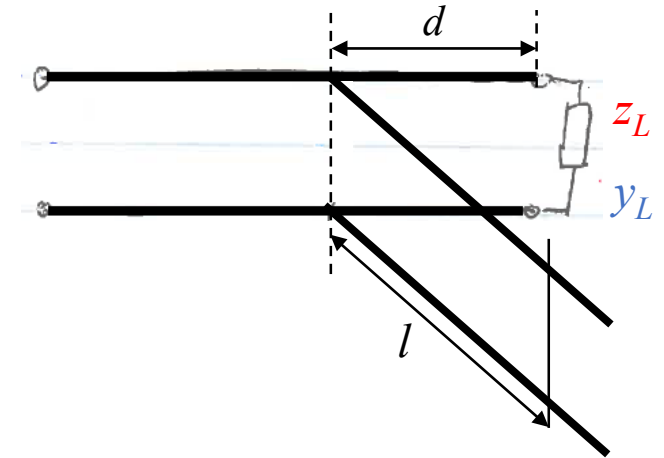

<https://www.moonraker.eu/antennas/antenna-hardware/ribbon-feeder/75-m-75-ohm-twin-feeder>

A few words about lab:

We have two lab tasks on impedance matching.

Single stub: We can't “slide” the stub on the main line to adjust d . Therefore we “adjust” the frequency.

Double stub: Two stub lengths are adjusted.

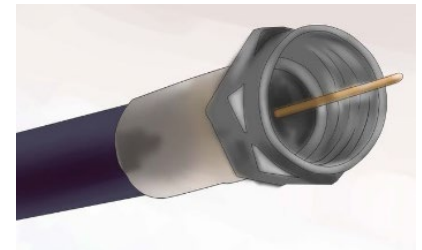

Sign up your lab time!

Lab

- Optional for this semester. Strongly encouraged. Documentation on course website.
- Incentive: 10 bonus points added to your final for a report clearly and correctly describe the principles of double-stub matching

Test 1

- Thu 3/18/2021, in-class. Will give extra time. When will be your next commitment?
- Covers contents up to Thu 3/11 lecture
- Concerns and suggestions?

Chapter 3 of Textbook

- Math knowledge & skills needed for the second half of the semester
- Read at an effort level suitable to you
- Start now
- Pay attention to notations: vectors, scalars, functions
- Homework 8

About the Course Website

- Lots of information
- ADS tutorial by the TAs
- A link to download the Smith chart
- All notes, homework & answers, and some quizzes with answers with grading guideline
- In the future, Tests and answers with grading guidelines
- Subject to frequent changes. Please check often
- Web address: <http://web.eecs.utk.edu/~ggu1/files/UGHome.html>

Quiz 3

A transmission line of characteristic impedance $Z_0 = 50 \Omega$ is terminated in a load $Z_L = 75 \Omega$. Is the load at a voltage maximum or a voltage minimum? (Not asking yes or no, but which.) Why?