

# Solution to ECE Test #4 S09

In the spaces provided write the letters of the DFT magnitudes corresponding to the discrete-time signals.

H  
I

F  
K

J  
E

D  
C

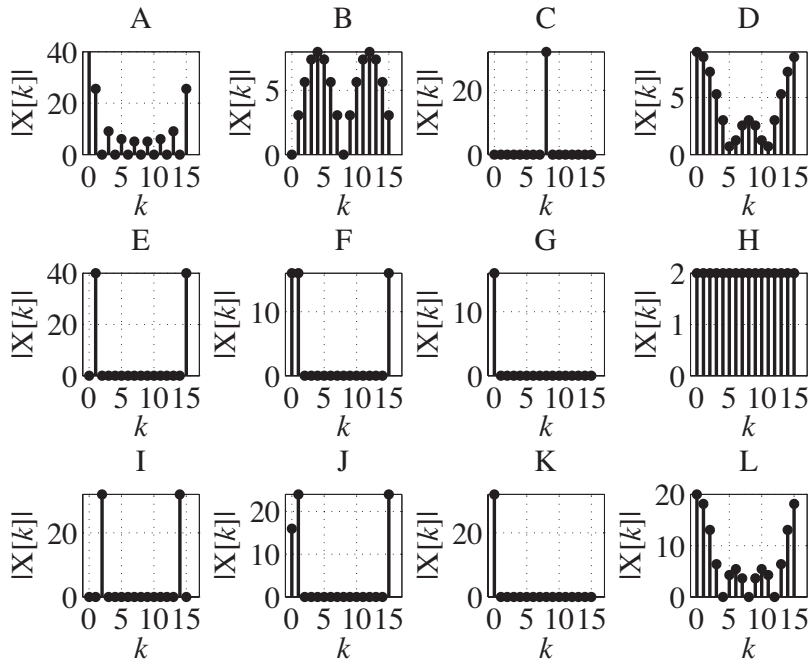
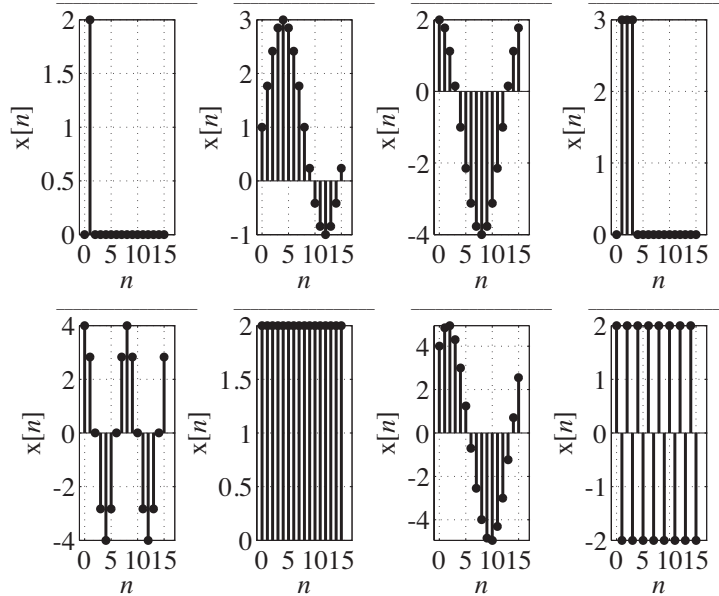

# Solution to ECE Test #4 S09

In the spaces provided write the letters of the DFT magnitudes corresponding to the discrete-time signals.

A                      B                      H                      E  
 D                      K                      G                      F

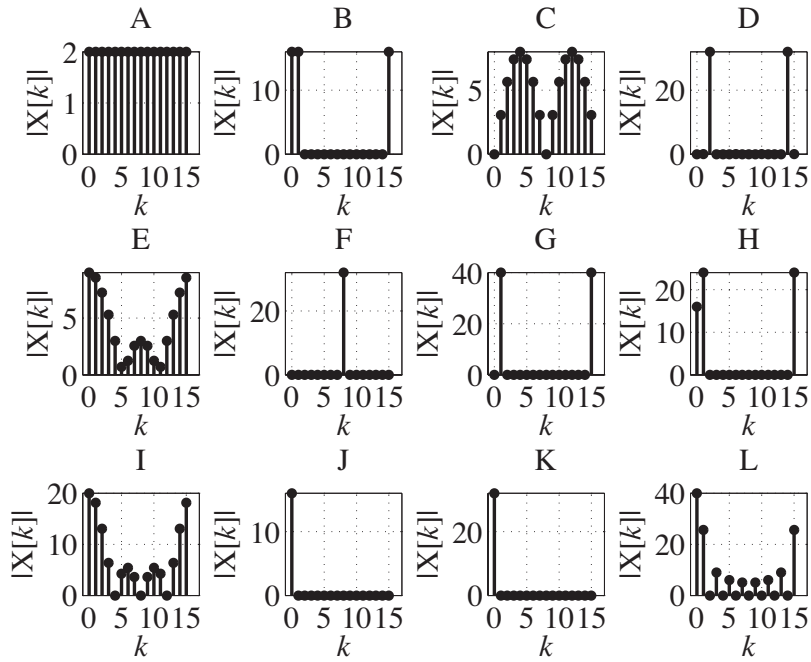
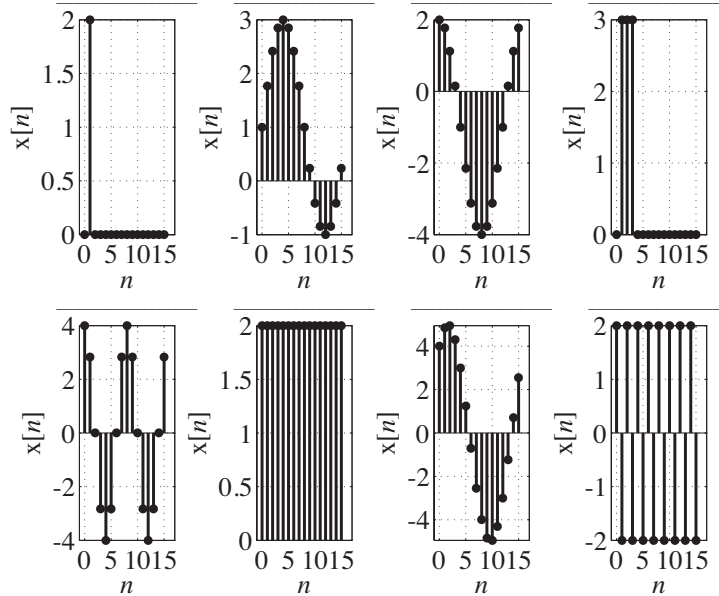

# Solution to ECE Test #4 S09

In the spaces provided write the letters of the DFT magnitudes corresponding to the discrete-time signals.

F                    I                    C                    B  
H                    K                    L                    D

